

FARNELL INSTRUM

Issue No. : 151RJ00008160

Date of Issue : March 03.2008

Classification : New Changed

PRODUCT SPECIFICATION FOR APPROVAL

Product Description : Anti-Pulse Thick Film Chip Resistors (RoHS Appliance)

Product Part Number : ERJT06J * * * V

Country of Origin : JAPAN

Applications : Standard electronic equipment

*If you approve this specification, please fill in and sign the below and return 1 copy to us.

Approval No	:	
Approval Date	:	
Executed by	:	

		(signature)
Title	:	
Dept.	:	

Circuit Components Business Unit
Panasonic Electronic Devices Co., Ltd.

401 Sadamasa-cho,
Fukui City 910-8502 Japan

Phone : +81-776-56-8034

Fax : +81-776-56-3114

Prepared by : Engineering Section

Contact Person :

Signature

Name(Print)

Title

S. Oota

S. Oota

Authorized by :

Signature

Name(Print)

Title

S. Hoshitoku

S. Hoshitoku

Manager of Engineering

Panasonic

Subject	PRODUCT SPECIFICATION FOR IMFORMATION	Spec. No.
Chip Resistor		151-SRJ-ET0601A
Part No.	ERJT06	11 - 1

1. Dimension

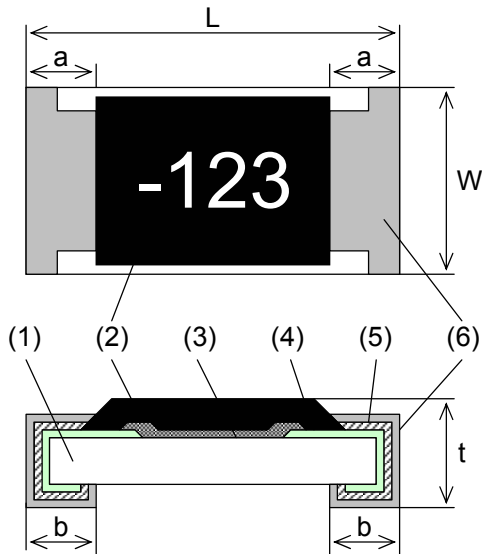

- (1) Substrate : Alumina
- (2) Protective Coating : Resin
- (3) Resistive Element : Metal glaze
- (4) Inner Termination : Thick film material
- (5) Middle Termination : Ni Plating
- (6) Outer Termination : Sn Plating

	L	W	a	b	t
Dimension (mm)	2.00+/-0.20	1.25+/-0.10	0.25+/-0.20	0.50+/-0.20	0.60+/-0.10

2. Power Derating Curve

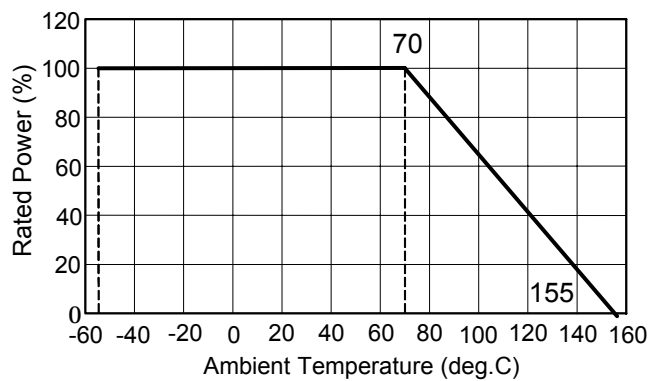

Operating temperature range
: -55 to 155 deg.C

Figure 1

3. Ratings

Item	Rated value	Explanation
Power Rating	0.25W	When used at ambient temperature above 70 deg.C, power rating shall be determined in accordance with Figure 1.

Subject	Chip Resistor	PRODUCT SPECIFICATION FOR IMFORMATION	Spec. No.	151-SRJ-ET0601A
Part No.	ERJT06		11 - 2	

Item	Rated value	Explanation
Rated voltage & Rated Continuous Working Voltage		The rated voltage of each resistance should be calculated from the equation below. And when the rated voltage exceeds the maximum RCWV, the maximum RCWV should be the rated voltage. $\text{Rated voltage (V)} = \sqrt{\text{Power rating (W)} \times \text{Resistance value } (\Omega)}$ The maximum RCWV : 150 V
Max. Overload Voltage		The overload voltage should be 2.5 times the rated voltage. And when the voltage exceeds the maximum overload voltage, the value shown below should be the maximum overload voltage. The maximum overload voltage : 200 V
Resistance Tolerance	J : +/- 5%	
Resistance range	1.0 ~ 1.0M ohm	(E-24)

4. Explanation of Part Number

E	R	J	T	0	6	J	1	0	0	V
(1)		(2)		(3)		(4)		(5)		

(1) Product Code : Thick Film Chip Resistor

(2) Size and Rated Power : 2.0 mm x 1.25 mm, 0.25W

T : Anti-Pulse type

(3) Resistance Tolerance

Code	Resistance Tolerance
J	+/- 5%

(4) Resistance Value

The first two digits are the significant figures of resistance value, and the last figure shows the number of zero following in ohm. And decimal point is expressed by "R".

(5) Packaging Configuration

Code	Packaging Configuration
V	Taping (5000pcs/reel)

Subject	PRODUCT SPECIFICATION FOR INFORMATION	Spec. No.
Chip Resistor		151-SRJ-ET0601A
Part No.	ERJT06	11 - 3

5. Appearance & Construction

Item	Rated value	Explanation
Appearance & Construction		<ol style="list-style-type: none"> 1. The resistive element should be covered with protective coating that don't fade easily. The surface of coating should avoid unevenness, flaw, pinhole and discoloration. 2. The electrode should be printed uniformly, as shown in the dimensions. The plating should not fade easily, and should avoid unevenness, flaw, pinhole, projection and discoloration. 3. The electrode should be connected electrically, mechanically to resistive element. 4. Dimensions of the substrate should be as in the list and it should not have chipping, flaw, flash and crack. Details of appearance criteria shall be as described in attached sheet.

As far as there shall not designation especially, the following tests and measurement shall be operated under the following conditions.

Normal temperature : 5 deg.C to 35 deg.C

Normal humidity : 45 % to 85 %

Normal atmospheric pressure : 86 k Pa to 106 k Pa

Subject	PRODUCT SPECIFICATION FOR IMFORMATION	Spec. No.
Chip Resistor		151-SRJ-ET0601A
Part No.	ERJT06	11 - 4

6. Performance Specification

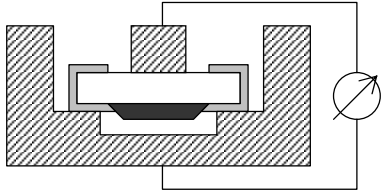
Item	Specification	Test Method (JIS-C5201-1)										
DC resistance	DC resistance value shall be within the specified tolerance.	At 20 deg.C, 65%RH										
Temperature coefficient of resistance (TCR)	<table border="1"> <thead> <tr> <th>R (Ω)</th> <th>TCR (x10⁻⁶/°C)</th> </tr> </thead> <tbody> <tr> <td>< 10</td> <td>-100 to +600</td> </tr> <tr> <td>10 ~30</td> <td>±300</td> </tr> <tr> <td>33 ~ 1M</td> <td>±200</td> </tr> </tbody> </table>	R (Ω)	TCR (x10 ⁻⁶ /°C)	< 10	-100 to +600	10 ~30	±300	33 ~ 1M	±200	Natural resistance change per temperature degree centigrade. $TCR = (R_2 - R_1) \times 10^6 / R_1 (t_2 - t_1)$ (x10 ⁻⁶ /deg.C) R ₁ : Resistance value at reference temperature (t ₁) R ₂ : Resistance value at test temperature (t ₂) t ₁ : 25 deg.C , t ₂ : 155 deg.C		
R (Ω)	TCR (x10 ⁻⁶ /°C)											
< 10	-100 to +600											
10 ~30	±300											
33 ~ 1M	±200											
Short time overload	ΔR : +/- (2%+0.1 ohm)	Resistors shall be applied 2.5 times the rated voltage for 5 seconds. Max. overload voltage shall be 200V.										
Intermittent overload	ΔR : +/- (5%+0.1 ohm)	Resistors shall be subjected to 10000 cycles of 2.5 times the rated voltage applied for 1 second with pause of 25 seconds between tests. Max. overload voltage shall be 200V.										
Dielectric Withstanding	No evidence of flashover, mechanical damage, arcing or insulation breakdown	AC 200V between substrate and termination for 1 minute. 										
Insulation resistance	Min. 1000M ohm	Resistors shall be facing down. After applying DC 200V to the resistor, insulation resistance shall be measured.										
Noise	<table border="1"> <thead> <tr> <th>R. value</th> <th>Noise</th> </tr> </thead> <tbody> <tr> <td>R ≤ 1k ohm</td> <td>-10dB(0.32μV/V)</td> </tr> <tr> <td>R < 10k ohm</td> <td>-5dB(0.56μV/V)</td> </tr> <tr> <td>R < 100k ohm</td> <td>0dB(1.0μV/V)</td> </tr> <tr> <td>R < 1M ohm</td> <td>10dB(3.2μV/V)</td> </tr> </tbody> </table> Less than upper value	R. value	Noise	R ≤ 1k ohm	-10dB(0.32μV/V)	R < 10k ohm	-5dB(0.56μV/V)	R < 100k ohm	0dB(1.0μV/V)	R < 1M ohm	10dB(3.2μV/V)	Noise shall be measured by RESISTOR NOISE TEST SET MODEL 315C by Quan-Tech Div. Max. V _R shall be 35 dB.
R. value	Noise											
R ≤ 1k ohm	-10dB(0.32μV/V)											
R < 10k ohm	-5dB(0.56μV/V)											
R < 100k ohm	0dB(1.0μV/V)											
R < 1M ohm	10dB(3.2μV/V)											

Subject	PRODUCT SPECIFICATION FOR IMFORMATION	Spec. No.
Chip Resistor		151-SRJ-ET0601A
Part No.	ERJT06	11 - 5

7. Machinery characteristic

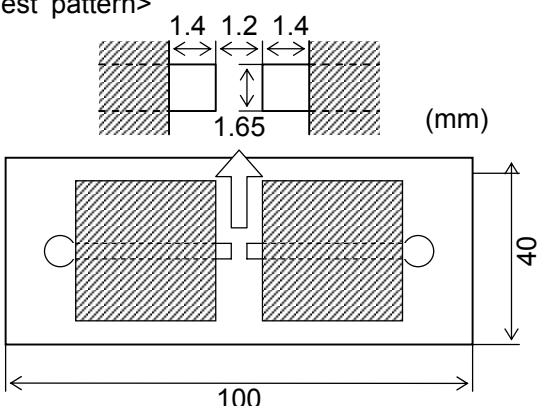
Item	Specification	Test Method (JIS-C5201-1)
Bending strength	No mechanical damage.	Substrate : Glass epoxy (t=1.6 mm) Span : 90mm Bending distance : 2mm (10 seconds) <Test pattern> 
	ΔR : +/- (1%+0.05 ohm)	
Solderability	Termination should be covered uniformly with solder (Min. 95% coverage)	Resistors shall be dipped in the melted solder bath at 235 deg.C +/- 5 deg.C for 2 seconds +/- 0.5 second. Flux shall be removed from the surface of termination with clean organic solvent.
Resistance to soldering heat	ΔR : +/- (1%+0.05 ohm)	Resistors shall be dipped in the melted solder bath at 270 deg.C +/- 3 deg.C for 10 seconds +/- 1 second.
Resistance to vibration (Low frequency)	ΔR : +/- (1%+0.05 ohm)	Resistors shall be subjected to a single vibration having as double amplitude of 1.5 mm in 3 directions perpendicular one another for 2 hours each. (6 hours in total) The vibration frequency shall be varied uniformly from 10 Hz to 55 Hz, and return to 10 Hz traversing for 1 min.
Resistance to solvent	Without distinct deformation in appearance	Solvent solution : Isopropyl alcohol (1)Dipping 10 +/- 1 hours, dry in room condition for 30 +/- 10 minutes. (2)Ultrasonic wave washing : 5 +/- 1 min. (0.3W/cm ² ,28kHz) Dry in room condition for 30 +/-10 minutes.
	ΔR : +/- (0.5% +0.05 ohm)	

Subject	PRODUCT SPECIFICATION FOR IMFORMATION	Spec. No.
Chip Resistor		151-SRJ-ET0601A
Part No.	ERJT06	11 - 6

8. Environmental test

Item	Specification	Test Method (JIS-C5201-1)															
Low temperature exposure	ΔR : +/- (1%+0.05 ohm)	Resistors shall be exposed at -55 deg.C +/- 3 deg.C with no load for 1000 hours +48/-0 hours.															
High temperature exposure	ΔR : +/- (1%+0.05 ohm)	Resistors shall be exposed at 155 deg.C +/- 3 deg.C with no load for 1000 hours +48/-0 hours.															
Temperature cycling	ΔR : +/- (1%+0.05 ohm)	Resistors shall be tested for 5 cycles continuously in accordance with the following duty cycle. <table border="1"> <thead> <tr> <th>Step</th> <th>Temperature (deg.C)</th> <th>Time (min.)</th> </tr> </thead> <tbody> <tr> <td>1</td> <td>-55 +/-3</td> <td>30</td> </tr> <tr> <td>2</td> <td>Room temperature</td> <td>Max. 3</td> </tr> <tr> <td>3</td> <td>+155 +/-3</td> <td>30</td> </tr> <tr> <td>4</td> <td>Room temperature</td> <td>Max.3</td> </tr> </tbody> </table>	Step	Temperature (deg.C)	Time (min.)	1	-55 +/-3	30	2	Room temperature	Max. 3	3	+155 +/-3	30	4	Room temperature	Max.3
Step	Temperature (deg.C)	Time (min.)															
1	-55 +/-3	30															
2	Room temperature	Max. 3															
3	+155 +/-3	30															
4	Room temperature	Max.3															
Humidity (Steady state)	ΔR : +/- (1%+0.05 ohm)	Resistors shall be exposed at 60 deg.C +/- 2 deg.C and 90% to 95% relative humidity in a humidity test chamber for 1000 hours +48/-0 hours.															
Load life	ΔR : +/- (3%+0.1 ohm)	Resistors shall be operated at DC rated voltage (1.5 hours "ON", 0.5 hours "OFF") for 1000 hours +48/-0 hours in a test chamber controlled at 70 deg.C +/-2 deg.C.															
Load life in humidity	ΔR : +/- (3%+0.1 ohm)	Resistors shall be operated at DC rated voltage (1.5 hours "ON", 0.5 hours "OFF") for 1000 hours +48/-0 hours in a test chamber controlled at 60 deg.C +/- 2 deg.C and at 90% to 95% in relative humidity.															

9. Resistance value marking

Express resistance value on resin side with three digits.

" - " : Anti-Pulse type



<Example>

-123 = 12k ohm

-2.2 = 2.2 ohm

The first two digits should be significant figures of resistance for E-24 series and the third one denotes number of zeros.

Decimal point should be expressed by ".".

Subject	PRODUCT SPECIFICATION FOR INFORMATION	Spec. No.
Chip Resistor		151-SRJ-ET0601A
Part No.	ERJT06	11 - 7

10. Common precautions in handling resistors

Notice for use

- (1) This specification shows the quality and performance of a unit component. Before adoption, be sure to evaluate and verify the product mounting it in your product.
- (2) We take no responsibility for troubles caused by the product usage that is not specified in this specification.
- (3) Use fail-safe design and ensure safety by carrying out the following items in cases where it is forecast that the failure of the product gives serious damage to something important like human life, for instant in traffic transportation equipment (trains, cars, traffic signal equipment, etc.), medical equipment, aerospace equipment, electric heating appliances, combustion and gas equipment, rotating equipment, disaster and crime preventive equipment.
 - *Ensure safety as the system by setting protective circuits and protective equipment.
 - *Ensure safety as the system by setting such redundant circuits as do not cause danger by a single failure.
- (4) When a dogma shall be occurred about safety for this product, be sure to inform us rapidly, operate your technical examination.
- (5) The product is designed to use in general standard applications of general electric equipment (AV products, household electric appliances, office equipment, information and communication equipment, etc.); hence, it do not take the use under the following special environments into consideration.

Accordingly, the use in the following special environments, and such environmental conditions may affect the performance of the product; prior to use, verify the performance, reliability, etc. thoroughly.

 - 1) Use in liquids such as water, oil, chemical, and organic solvent.
 - 2) Use under direct sunlight, in outdoor or in dusty atmospheres.
 - 3) Use in places full of corrosive gases such as sea breeze, Cl₂, H₂S, NH₃, SO₂, and NO_x.
 - 4) Use in environment with large static electricity or strong electromagnetic waves.
 - 5) Where the product is close to a heating component, and where an inflammable such as a polyvinyl chloride wire is arranged close to the product.
 - 6) Where the resistor is sealed or coated with resin, etc.
 - 7) Where water or a water-soluble detergent is used in cleaning free soldering and in flux cleaning after soldering (Pay particular attention to soluble flux.)
 - 8) Use in such a place where the product is wetted due to dew condensation.
- (6) If transient load (heavy load in a short time) like pulse is expected to be applied, carry out evaluation and confirmation test with resistors actually mounted on your own board. When the load of more than rated power is applied under the load condition at steady state, it may impair performance and/or reliability of resistor. Never exceed the rated power. When the product shall be used under special condition, be sure to ask us in advance.

Subject	Chip Resistor	PRODUCT SPECIFICATION FOR INFORMATION	Spec. No.	151-SRJ-ET0601A
Part No.	ERJT06		11 - 8	

- (7) Halogen type (Chlorine type, Bromine type, etc.) or other high-activity flux is not recommended as the residue may affect performance or reliability of resistors.
- (8) When soldering with soldering iron, never touch the body of the chip resistor with a tip of the soldering iron. When using a soldering iron with a tip at high temperature, solder for a time as short as possible. (three seconds or less up to 350 deg.C)
- (9) Avoid physical shock to the resistor and nipping of the resistor with hard tool (a pair of pliers or tweezers) as it may damage protective film or the body of resistor and may affect resistor's performance.
- (10) Avoid immersion of chip resistor in solvent for long time. Use solvent after the effect of immersion is confirmed.

11. Storage Method

If the product is stored in the following environments and conditions, the performance and solderability may be badly affected, avoid the storage in the following environments.

- (1) Storage in places full of corrosive gases such as sea breeze, Cl₂, H₂S, NH₃, SO₂, and NO_x.
- (2) Storage in places exposed to direct sunlight.
- (3) Storage in places outside the temperature range of 5 deg.C to 35 deg.C and humidity range of 45 %RH to 85 %RH.
- (4) Storage over a year after our delivery (This item also applies to the case where the storage method specified in item (1) to (3) has been followed.).

12. Laws and Regulations

- (1) This product has not been manufactured with any ozone-depleting chemical controlled under the Montreal Protocol.
- (2) This product complies with the RoHS Directive (Restriction of the use of certain Hazardous Substances in electrical and electronic equipment (DIRECTIVE 2002/95/EC)).
- (3) All materials used in this part are registered material under the Law Concerning the Examination and Regulation of Manufacturs, etc. of Chemical substances.
- (4) All the materials used in this part contain no brominated materials of PBBO_S or PBB_S as the flame-retardant.
- (5) If you need the notice by letter of "A preliminary judgement on the Laws of Japan foreign exchange and Foreign Trade control", be sure to let us know.

13. Production site

Country : Japan

Plant : Panasonic Electronic Devices Fukui Co., Ltd.

Subject	PRODUCT SPECIFICATION FOR INFORMATION	Spec. No.
Chip Resistor		151-SRJ-ET0601A
Part No.	ERJT06	11 - 9

14. Taped and Reel Package

14-1 Physical Dimensions

Structure and reel dimensions shall be as shown in the figure below.
In accordance with EIAJ ET-7200.

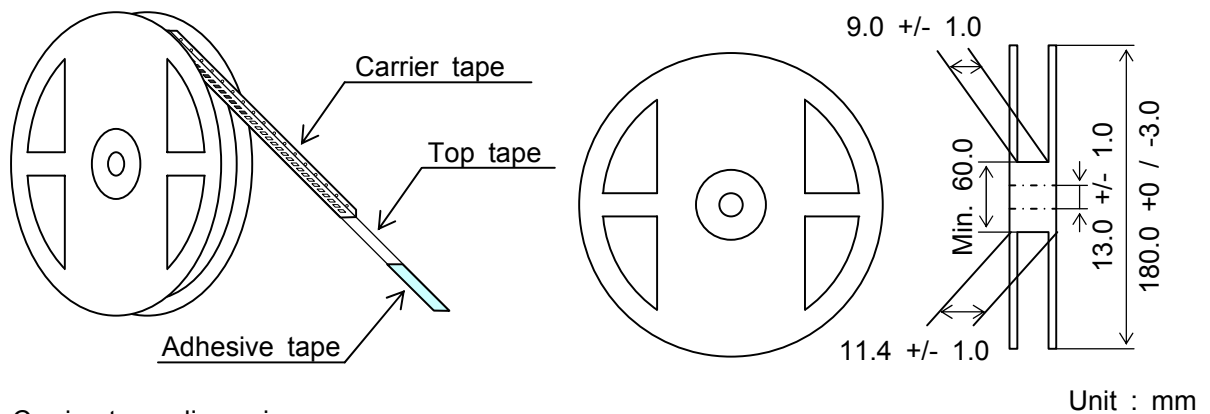

14-2 Carrier tape dimension

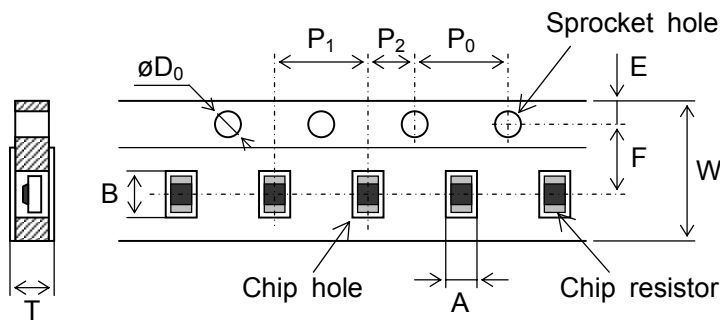

	A	B	W	F	E
Dimension (mm)	1.65+/-0.15	2.50+/-0.20	8.00+/-0.20	3.50+/-0.05	1.75+/-0.10

	P1	P2	P0	ϕD_0	T
Dimension (mm)	4.00+/-0.10	2.00+/-0.05	4.00+/-0.10	1.50+0.10/-0	0.84+/-0.05

14-3 Specifications

14-3-1 Taping

(1) Minimum Bending Radius

When Carrier tape shall be bent by Minimum Bending Radius (15mm), no deflection of chip and no break of carrier tape. However minimum bending radius shall be tested for 1 time.

(2) Resistance to climate of top tape

When it shall be exposed at 60 deg.C, 90 to 95 %RH for 120 hours, no exfoliation of top tape.

Subject	PRODUCT SPECIFICATION FOR INFORMATION	Spec. No.
Chip Resistor		151-SRJ-ET0601A
Part No.	ERJT06	11 - 10

(3) When the test shall be operated with the below conditions, peel strength should be 0.049 N to 0.49 N, should not have flash and tear after peeling.

(Test Method)

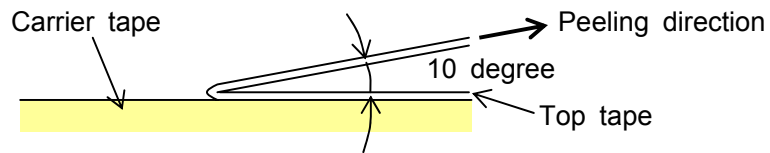

14-3-2 Quantity in Taping : 5000 pcs./reel

14-3-3 Tape packaging

- (1) Resistance side shall be facing upward.
- (2) Chip resistor shall not be sticking to top tape and bottom tape.
- (3) Chip resistor shall be easy to take out from carrier tape and chip hole or sprocket hole shall not have flash and break.

14-4 Outer Packaging

Quantity : 20 reels (Max. 100,000pcs.)

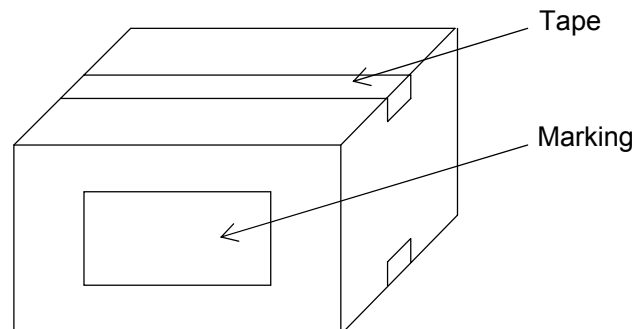

- * When taping shall not reach Max. or quantity, the remaining empty space shall be buried with buffer material.
- * When the quantity shall be few, alternative packaging methods may be used. No problem must occur during the exportation of the product.



14-5 Marking

At last, production country is displayed in English.

- (1) Side of reel (Marking shall be on one side)
 - 1)Part name, 2)Part number, 3)Quantity, 4)Lot number, 5)Maker name
 - 6)Poduction country
- (2)Packaging box
 - 1)Customer name, 2)Part name, 3)Part number, 4)Customer part number, 5)Quantity
 - 6)Maker name, 7) Poduction country

Subject	PRODUCT SPECIFICATION FOR INFORMATION	Spec. No.
Chip Resistor		151-SRJ-ET0601A
Part No.	ERJT06	11 - 11

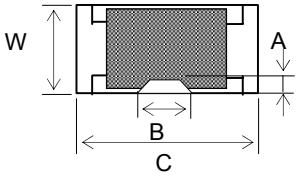
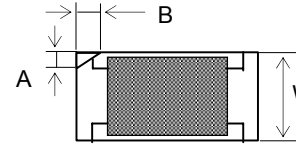
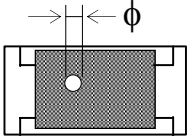
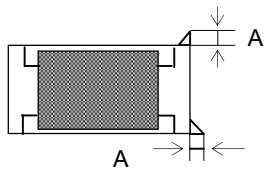
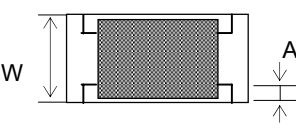
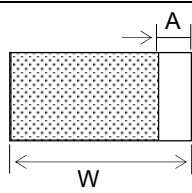
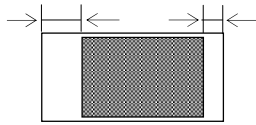
15. Appearance Quality Criteria

Item	Figure	Appearance quality criteria	Remark
Protective coating Chipping		$A \leq W/4$ $B \leq C/2$	Chipping on both sides shall be considered defective
Terminal Chipping		$A \leq W/4$ $B \leq \text{Terminal width}$	
Pin hole		One pin hole / chip resistor $\phi \leq 0.2 \text{ mm}$	Pin hole penetrates The resistive material.
Flash		$A \leq 0.1 \text{ mm}$	
Top terminal Lacking		$A \leq W/4$	
Side terminal Lacking		$A \leq W/4$	
Protective coating and terminal aberration		Protective coating and terminal aberration shall be within the terminal width dimension	
Marking		Marking must be readable.	