

POWERVERTER PV65R

12/24VDC USB CHARGERS IP65 PROTECTED

USB POWER WITH ADDED LIQUID & DUST INGRESS AND VIBRATION PROTECTION TO IP65

The PV65R range of USB chargers offers all the performance benefits of the PVPro range with additional protection provided to the electronic circuit of the unit. A durable polyurethane compound encompasses the electronic components offering comprehensive protection against dust and liquid ingress to IP65.

This product offers a good solution where tampering might be an issue or in dirty or more challenging environments. Although the nature of the USB connector itself can always be wilfully broken or damaged and will still corrode if repeatedly exposed to liquid ingress, all electronics in these units is protected to IP65.

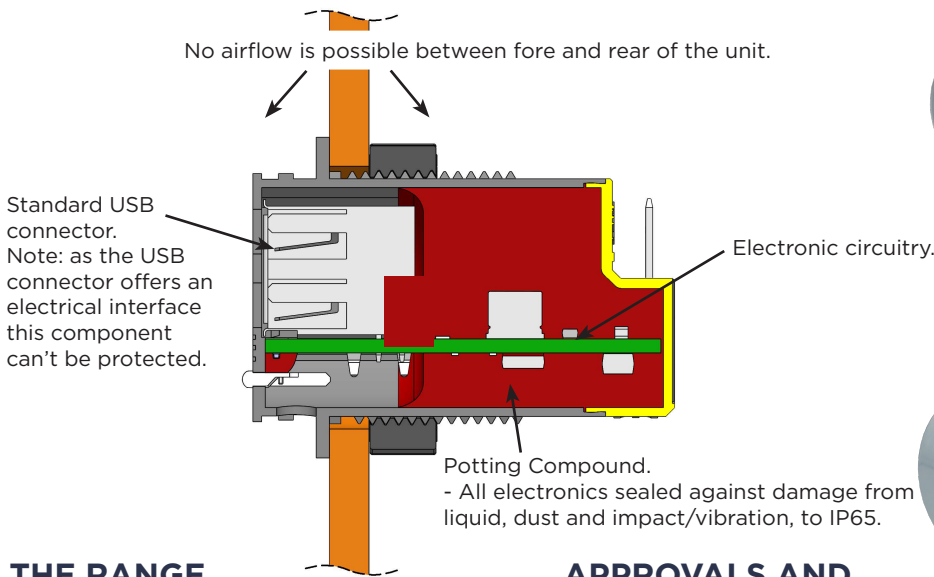

- Designed for demanding environments including bus, coach, off road and railway applications.
- Electronics protected to IP65.
- Extra vibration protection to EN61373.
- Approved to EN50498, ISO7637-2 and EN50155. E marked (Reg10) and CE marked.



PowerVerter PV65R-S and PV65R-D single and double outlets.



The Front facing version can be screwed in place from the front, then covered with the attractive ring to avoid tampering. Available in both single (PV65R-SFF) and double outputs (PV65R-DFf).

THE RANGE

The range mirrors the very successful PVPro products, offering both single and double outputs and rear fit as well as front fitting options which allow the unit to be replaced quickly and easily should this be required. Automatic short circuit protection is also included, so in the event of tampering or compromise, the unit will automatically shut down, then re-start once the fault has been removed. All units can be installed on both 12Vdc or 24Vdc vehicles without adjustment.

Units can be installed directly into bulkheads, vehicle walls, into seat fittings and underneath seats using the mounting pod P/N USB-POD. They can also be fitted onto table tops using the horizontal surface mounting pod P/N USB-TPOD.

APPROVALS AND MANUFACTURE

The range has been designed to meet the rigorous standards required for on board commercial vehicle applications including EN50498, ISO7637-2, EN61373 and EN50155 and is both CE and E marked (Reg10). The casings are made from VO rated (self-extinguishing) high impact polycarbonate and the electronic assembly is predominantly by computer controlled SMT for maximum durability.

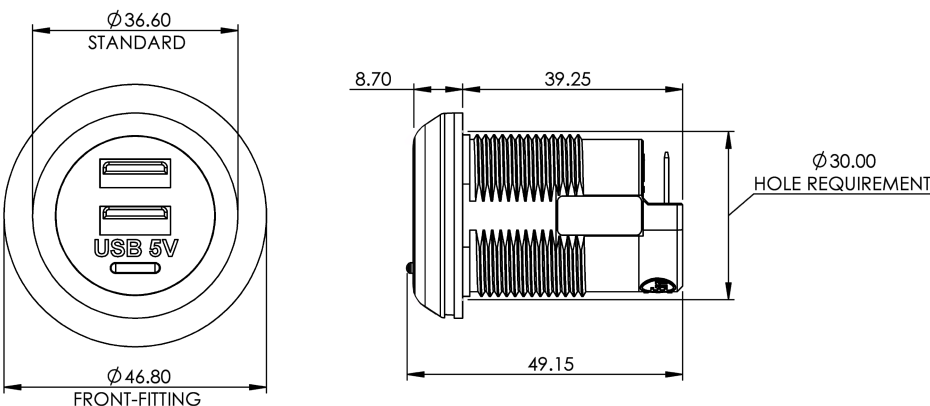

WARRANTY

The PV65R range of chargers are manufactured using rugged components to provide years of service in demanding commercial environments and are covered by a three year return to base guarantee.

CHOOSE YOUR PV65R PRODUCT

Part Number	Description	Dimensions (mm)	Weight
PV65R-S	Single output 12/24-5V USB Charger 2.1A	Ø37 x 49; Hole Ø30; Rear space req. typ. 36	36g
PV65R-D	Double output 12/24-5V USB Charger 3.0A (1.5A per socket)	Ø37 x 49; Hole Ø30; Rear space req. typ. 36	40g
PV65R-SFf	Single output 12/24-5V USB 2.1A Front fitting	Ø47 x 49; Hole Ø30; Rear space req. typ. 36	39g
PV65R-DFf	Double output 12/24-5V USB Charger 3.0A Front fitting	Ø47 x 49; Hole Ø30; Rear space req. typ. 36	43g
USB-POD	Under-seat mounting pod for USB Chargers	Width 60; Height 52; Depth 80	69g
USB-TPOD	Table mounting pod for USB Chargers	Width 103; Height 44.5; Depth 88	73g
PV-USB-H1	Standard 1.2m wiring with in-line 2A fuse	1 x Red 1.2m, 1 x Black 1.2m	50g

TECHNICAL DATA

Input voltage range	9-32Vdc
Output voltage	5Vdc +/- 0.2V
Output Power	2.1A (single), 3.0A (double) - max 1.5A per socket
Application	Charges all USB devices including Apple and Android
Transient voltage protection	Meets ISO7637-2 International standard for 12/24V vehicles
Output noise	<50mV pk-pk
Off load current (quiescent current)	<1.7mA
Power conversion efficiency	90%
Isolation	Non-Isolated, >400Vrms only between casing and terminals. For full galvanic isolation, see PV6i-R, PV12i-R.
Operating temperature	-25°C to +55°C to meet this specification table
Storage temperature	-25°C to +100°C
Operating humidity	95% max., non-condensing
Casework	Dark grey polycarbonate body, with yellow end cap
Connections	Input: 6.3mm push-in flat blade connectors Output: USB type 'A' single/double socket - tested to 10,000 mating cycles
Output indicator	Blue LED output indication
Mounting method	30mm diameter hole with or without bezel.
Safe area protection:	<ul style="list-style-type: none"> Over Current Limited by current sensing circuit Over heat Limited by temperature sensing circuit Overvoltage and Undervoltage Limited by sensing circuit Reverse Polarity Limited by sensing circuit Transients Protected by filters and rugged component selection Catastrophic protection Internal fuse
Approvals	2014/30/EU The general EMC directive Regulation 10 The automotive directive 93/68/EEC The CE marking directive
Designed to	EN50498, EN61373, EN50155, EN50121-3-2, EN45545 & ISO 7637-2, AES5, R118 To meet railway approval to EN50155, EN45542-2 & EN50121-3-2 the PVPro is to be used in conjunction with a PV6i-R, PV12i-R or PV24i-R
Markings	CE and E marked
IP Rating:	IP65 (Not USB connector). Cleaning: wipe with damp cloth, do not spray.