



MP3398H

4-String, Max 400mA/String, 80V Return, Step-Up WLED Controller

DESCRIPTION

The MP3398H is a step-up controller with four LED current channels, designed to drive WLED arrays for large LCD panel backlighting applications. The MP3398H can expand the number of LED channels with two or more ICs in parallel sharing a single power source.

The MP3398H employs peak current control mode with a fixed switching frequency (f_{sw}) that is configurable via an external setting resistor. The MP3398H drives an external MOSFET to boost the output voltage (V_{OUT}) from a 4.5V to 33V input voltage (V_{IN}) supply. The device also regulates the current in each LED string to the value set by an external current-setting resistor.

The MP3398H applies four internal current sources for current balancing. It achieves 1.5% current matching regulation accuracy between the strings. The low regulation voltage on the LED current sources reduces power loss.

The MP3398H supports direct pulse-width modulation (PWM) dimming mode with a PWM input and analog dimming mode with a PWM input or DC input. Full protection features include over-current protection (OCP), over-temperature protection (OTP), under-voltage protection (UVP), over-voltage protection (OVP), LED short and open protection, and inductor and diode short protection.

The MP3398H is available in an SOIC-16 package.

FEATURES

- 4-String, Max 400mA/String WLED Driver
- 4.5V to 33V Input Voltage (V_{IN}) Range
- 80V Absolute Maximum Rating for Each String
- 1.5% Current Matching Accuracy between Each String
- Direct Pulse-Width Modulation (PWM) Dimming Mode
- Analog Dimming Mode via PWM Input or DC Input
- Cascading Capability with a Single Power Source
- LED Open and Short Protection
- Configurable, Recoverable Over-Voltage Protection (OVP)
- 540mV Cycle-by-Cycle Current Limit
- Hiccup Over-Temperature Protection (OTP)
- Short Inductor and Diode Protection
- Available in an SOIC-16 Package

APPLICATIONS

- Desktop LCD Flat-Panel Displays
- All-in-One PCs
- 2D and 3D LCD TVs

All MPS parts are lead-free, halogen-free, and adhere to the RoHS directive. For MPS green status, please visit the MPS website under Quality Assurance. "MPS," the MPS logo, and "Simple, Easy Solutions" are trademarks of Monolithic Power Systems, Inc. or its subsidiaries.

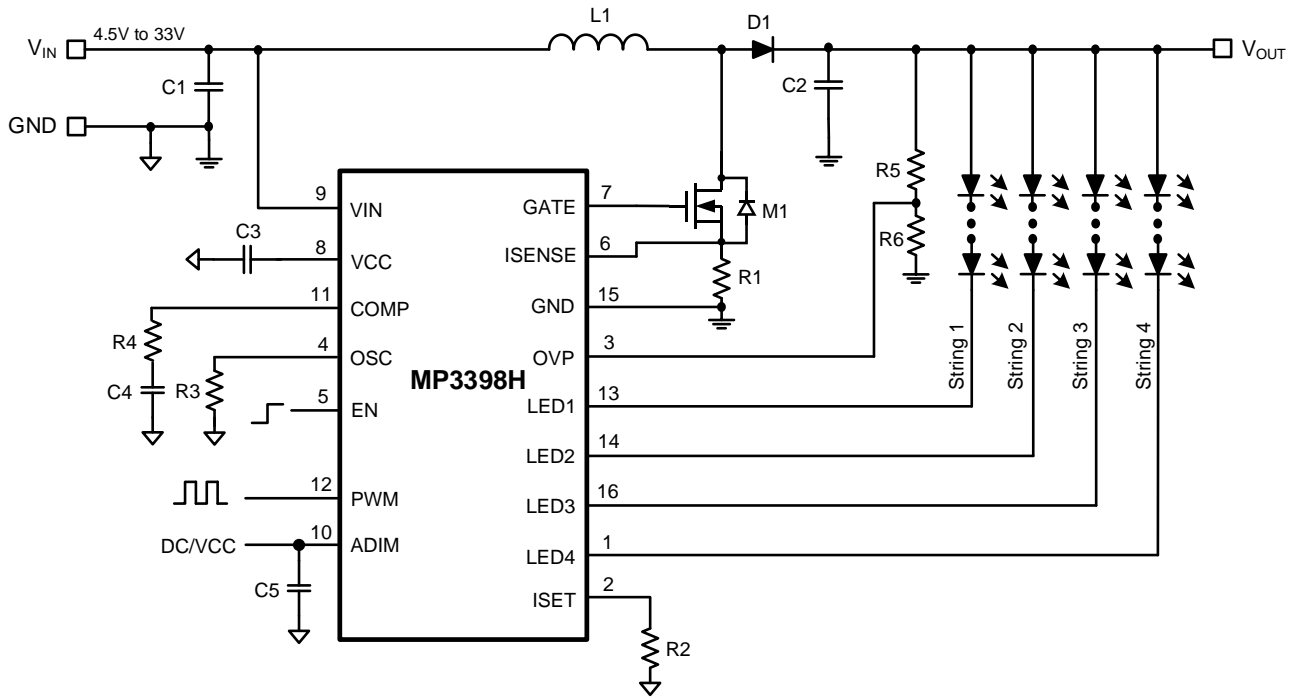
TYPICAL APPLICATION

ORDERING INFORMATION

Part Number*	Package	Top Marking	MSL Rating
MP3398HGS	SOIC-16	See Below	2

* For Tape & Reel, add suffix -Z (e.g. MP3398HGS-Z).

TOP MARKING

MPSYYWW
MP3398H
LLLLLLLLLL

MPS: MPS prefix
 YY: Year code
 WW: Week code
 MP3398H: Part number
 LLLLLLLLLL: Lot number

PACKAGE REFERENCE

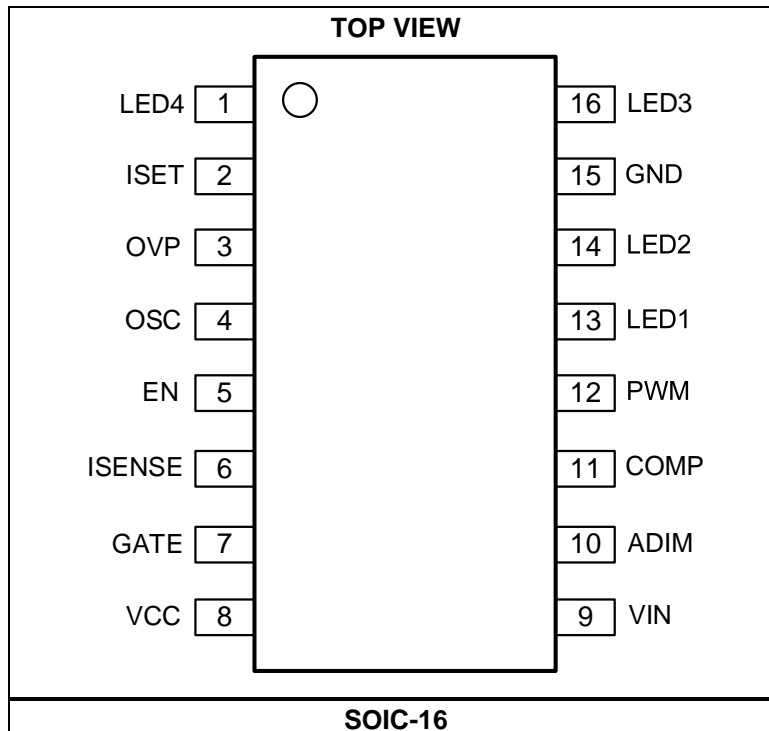

PIN FUNCTIONS

Pin #	Name	Description
1	LED4	LED string 4 current input. The LED4 pin is the open-drain output of an internal dimming control switch. Connect LED4 to the LED string 4 cathode.
2	ISET	LED current (I_{LED}) setting. Connect a current-setting resistor from the ISET pin to ground to configure the current for each LED string.
3	OVP	Output over-voltage protection (OVP). Connect a resistor divider from the output to the OVP pin to configure the OVP threshold.
4	OSC	Switching frequency (f_{sw}) setting. Connect a resistor (R_{OSC}) between the OSC pin and GND to set the step-up converter's f_{sw} . The clock frequency is proportional to the current sourced from OSC.
5	EN	Enable control input. Pull EN above 1.5V to turn on the part; pull EN below 0.6V to turn off the part. Do not float the EN pin.
6	ISENSE	Current-sense input. During normal operation, the ISENSE pin senses the voltage across the external inductor current-sense resistor (R_{SENSE}) for peak current control mode. ISENSE also limits the inductor current (I_L) during every switching cycle. If the MP3398H is used for cascading applications, connect the slave IC's ISENSE pin to GND. Do not float ISENSE.
7	GATE	Power MOSFET driver output for the step-up converter. The GATE pin drives the external N-channel power MOSFET.
8	VCC	Internal 5.9V linear regulator output. The VCC pin provides the power supply for the external MOSFET gate driver and the internal control circuitry. Bypass VCC to GND using a ceramic capacitor.
9	VIN	Supply input. The VIN pin must be bypassed locally.
10	ADIM	Input signal for analog brightness control. For analog dimming with a pulse-width modulation (PWM) input, connect a capacitor between the ADIM pin and GND, then apply a PWM signal to the PWM pin. The I_{LED} amplitude is determined by the duty cycle of the PWM signal applied to PWM. An internal 100k Ω resistor combined with an external capacitor form the filter that is used to obtain the I_{LED} reference. A frequency exceeding 20kHz is recommended to achieve improved PWM signal filtering performance. For analog dimming with a DC input, pull PWM high to VCC or pull PWM down to GND, then apply a 0V to 1.5V DC voltage on ADIM to adjust the I_{LED} amplitude from 0% to 100%.
11	COMP	Step-up converter compensation. The COMP pin compensates for the regulation control loop. Connect a ceramic capacitor or a resistor combined with a capacitor from COMP to GND.
12	PWM	Input signal for PWM brightness control. For direct PWM dimming, pull ADIM high to VCC, then apply a PWM signal to PWM. I_{LED} is chopped and the average I_{LED} is equal to $I_{SET} \times D_{DIM}$, where I_{SET} is the I_{LED} amplitude set by a resistor between ISET and GND, and D_{DIM} is the PWM dimming signal duty cycle. For analog dimming with a PWM input, apply a PWM signal exceeding 20kHz on PWM. Ensure that the high-level voltage exceeds 1.5V, and the low-level voltage is below 0.4V. If PWM is floating, weakly pull PWM to GND internally.
13	LED1	LED string 1 current input. The LED1 pin is the open-drain output of an internal dimming control switch. Connect LED1 to the LED string 1 cathode.
14	LED2	LED string 2 current input. The LED2 pin is the open-drain output of an internal dimming control switch. Connect LED2 to the LED string 2 cathode.
15	GND	Ground.
16	LED3	LED string 3 current input. The LED3 pin is the open-drain output of an internal dimming control switch. Connect LED3 to the LED string 3 cathode.

ABSOLUTE MAXIMUM RATINGS ⁽¹⁾

V_{IN}	-0.3V to +40V
V_{LED1} to V_{LED4}	-0.3V to +80V
All other pins	-0.3V to +6.5V
Continuous power dissipation ($T_A = 25^\circ\text{C}$) ⁽²⁾	
SOIC-16	1.56W
Junction temperature	150°C
Lead temperature	260°C
Storage temperature	-60°C to +150°C

Recommended Operating Conditions ⁽³⁾

Supply voltage (V_{IN})	4.5V to 33V
Max LED current (I_{LED_MAX})	400mA
Operating junction temp	-40°C to +125°C

Thermal Resistance ⁽⁴⁾	θ_{JA}	θ_{JC}
SOIC-16	80.....	35.....°C/W

Notes:

- 1) Exceeding these ratings may damage the device.
- 2) The maximum allowable power dissipation is a function of the maximum junction temperature, T_J (MAX), the junction-to-ambient thermal resistance, θ_{JA} , and the ambient temperature, T_A . The maximum allowable continuous power dissipation at any ambient temperature is calculated by P_D (MAX) = $(T_J$ (MAX) - T_A) / θ_{JA} . Exceeding the maximum allowable power dissipation can produce an excessive die temperature, which may cause the regulator to go into thermal shutdown. Internal thermal shutdown circuitry protects the device from permanent damage.
- 3) The device is not guaranteed to function outside of its operating conditions.
- 4) Measured on JESD51-7, a 4-layer PCB.

ELECTRICAL CHARACTERISTICS

$V_{IN} = 12V$, $V_{EN} = 5V$, $T_A = 25^\circ C$, unless otherwise noted.

Parameters	Symbol	Condition	Min	Typ	Max	Unit
General						
Operating input voltage	V_{IN}		4.5		33	V
Quiescent supply current	I_Q	$V_{IN} = 12V$, no switching		3.85	4.5	mA
Shutdown supply current	I_{ST}	$V_{EN} = 0V$, $V_{IN} = 12V$			1	μA
Low-dropout (LDO) output voltage	V_{CC}	$7V < V_{IN} < 28V$, $0 < I_{VCC} < 10mA$	5.5	5.9	6.3	V
V_{CC} under-voltage lockout (UVLO) threshold	V_{CC_UVLO}	Rising edge	3.7	4	4.3	V
V_{CC} UVLO hysteresis				350		mV
EN high voltage	V_{EN_HIGH}	V_{EN} rising	1.5			V
EN low voltage	V_{EN_LOW}	V_{EN} falling			0.6	V
Step-Up Converter						
Gate driver source impedance		$V_{CC} = 5.9V$, $V_{GATE} = 5.9V$		4		Ω
Gate driver sink impedance		$V_{CC} = 5.9V$, $I_{GATE} = 10mA$		2.5		Ω
Switching frequency	f_{SW}	$R_{OSC} = 100k\Omega$	400	500	600	kHz
Maximum duty cycle	D_{MAX}	$R_{OSC} = 100k\Omega$	90			%
Cycle-by-cycle ISENSE current limit			480	540	600	mV
Latch-off current limit			720	800	880	mV
COMP source current limit	I_{COMP_SOLI}	$1V < COMP < 2.9V$		30		μA
COMP sink current limit	I_{COMP_SILI}	$1V < COMP < 2.9V$		18		μA
COMP transconductance	G_{COMP}	$\Delta I_{COMP} = \pm 10\mu A$		120		$\mu A/V$
Current Dimming						
PWM input low threshold	V_{PWM_LO}	V_{PWM} falling			0.4	V
PWM input high threshold	V_{PWM_HI}	V_{PWM} rising	1.5			V
ADIM input DC range	V_{ADIM}		0		1.5	V
Internal resistor on ADIM	R_{ADIM}		70	100	130	k Ω
Current Regulation						
ISET voltage	V_{ISET}		1.46	1.5	1.54	V
LEDx average current	I_{LEDx}	$R_{ISET} = 12k\Omega$	97	100	103	mA
Current matching ⁽⁵⁾		$I_{LED} = 100mA$		1	1.5	%
LEDx regulation voltage		$I_{LED} = 100mA$		360		mV
		$I_{LED} = 60mA$		285		mV
Protection						
Over-voltage protection (OVP) threshold	V_{OVP}		1.9	2	2.1	V
OVP UVLO threshold	V_{OVP_UVLO}	Step-up converter fails		55		mV
LEDx UVLO threshold	V_{LEDx_UVLO}			200		mV
LEDx over-voltage (OV) threshold	V_{LEDx_OV}		7	8	9	V
Thermal protection threshold	T_{ST}			150		$^\circ C$
Thermal protection hysteresis				25		$^\circ C$

Note:

5) Matching is defined as the difference between the maximum to minimum current divided by twice the average current.

TYPICAL PERFORMANCE CHARACTERISTICS

$V_{IN} = 19V$, $V_{EN} = 3.3V$, 120mA/string, 4 strings, 20 LEDs in series, $T_A = 25^\circ C$, unless otherwise noted.

Steady State

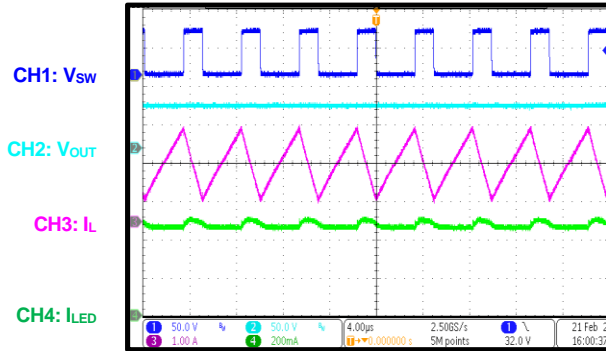

Start-Up through VIN

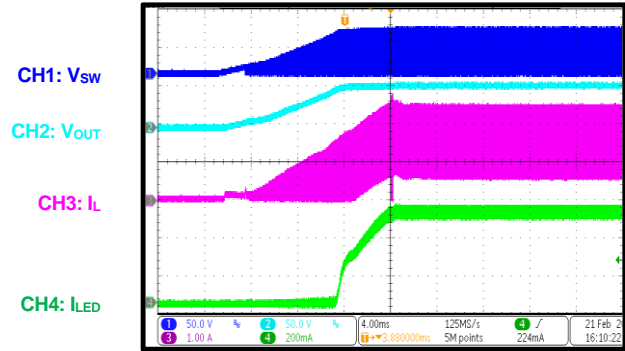

Start-Up through EN

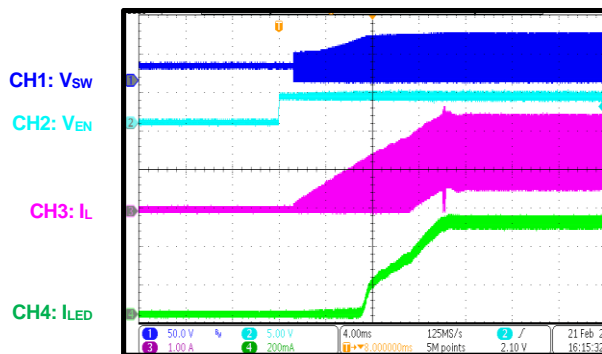

PWM Dimming

$f_{PWM} = 200Hz$, $D_{PWM} = 50\%$

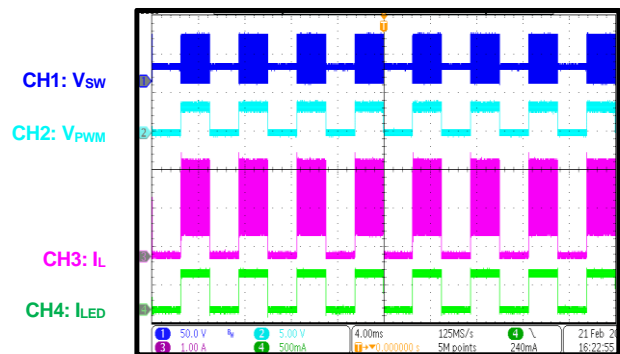

Analog Dimming with PWM Input

$f_{PWM} = 20kHz$, $D_{PWM} = 50\%$

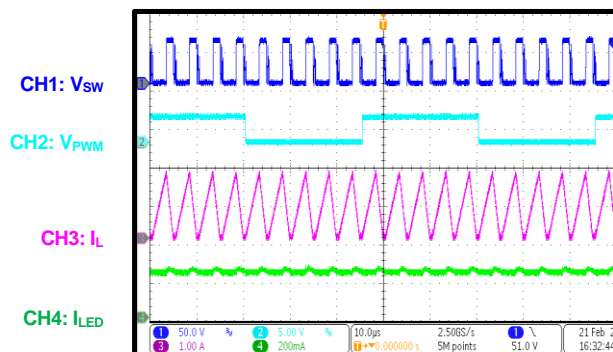

Analog Dimming with DC Input

$V_{ADIM} = 0.75V$

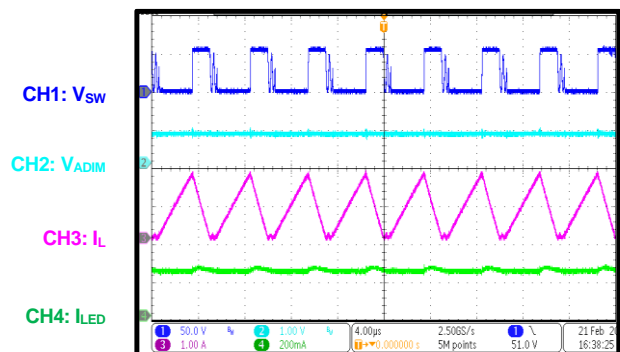

TYPICAL PERFORMANCE CHARACTERISTICS (continued)

$V_{IN} = 19V$, $V_{EN} = 3.3V$, 120mA/string, 4 strings, 20 LEDs in series, $T_A = 25^\circ C$, unless otherwise noted.

LED Open Protection

Open one LED string during operation

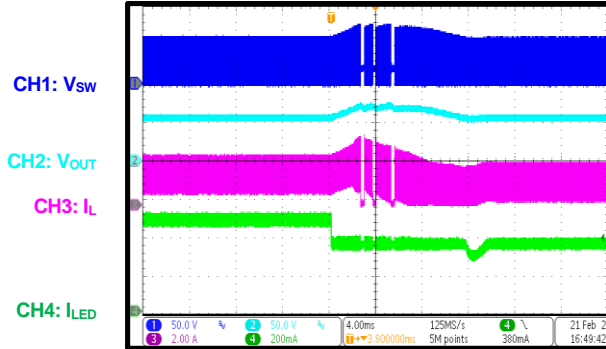
LED Short Protection

Short one LED string during operation

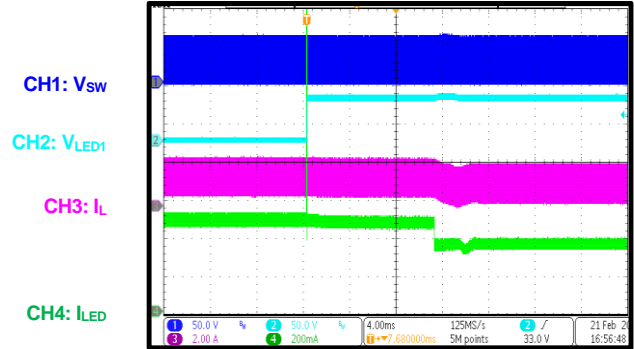
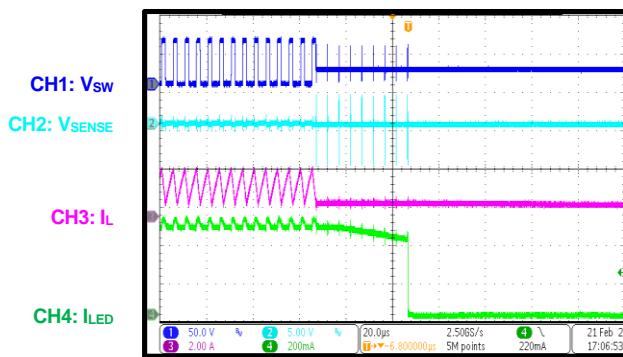
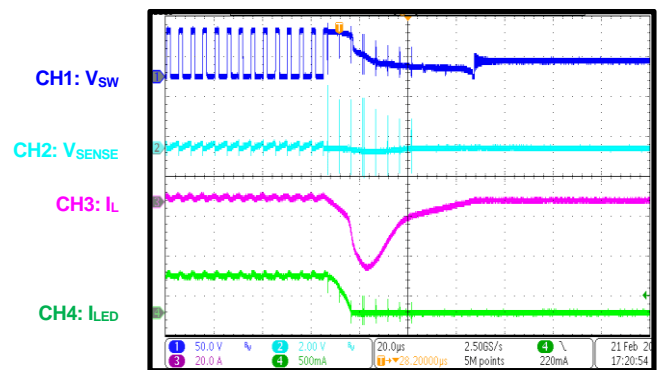
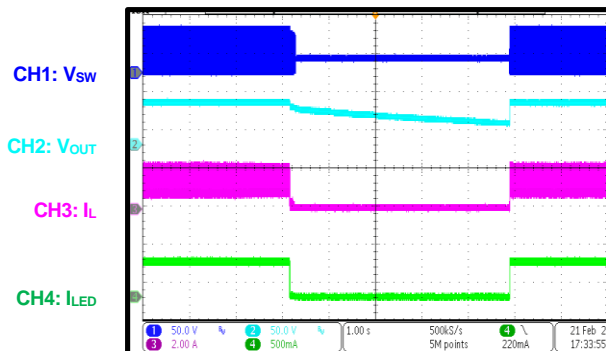
Inductor Short Protection

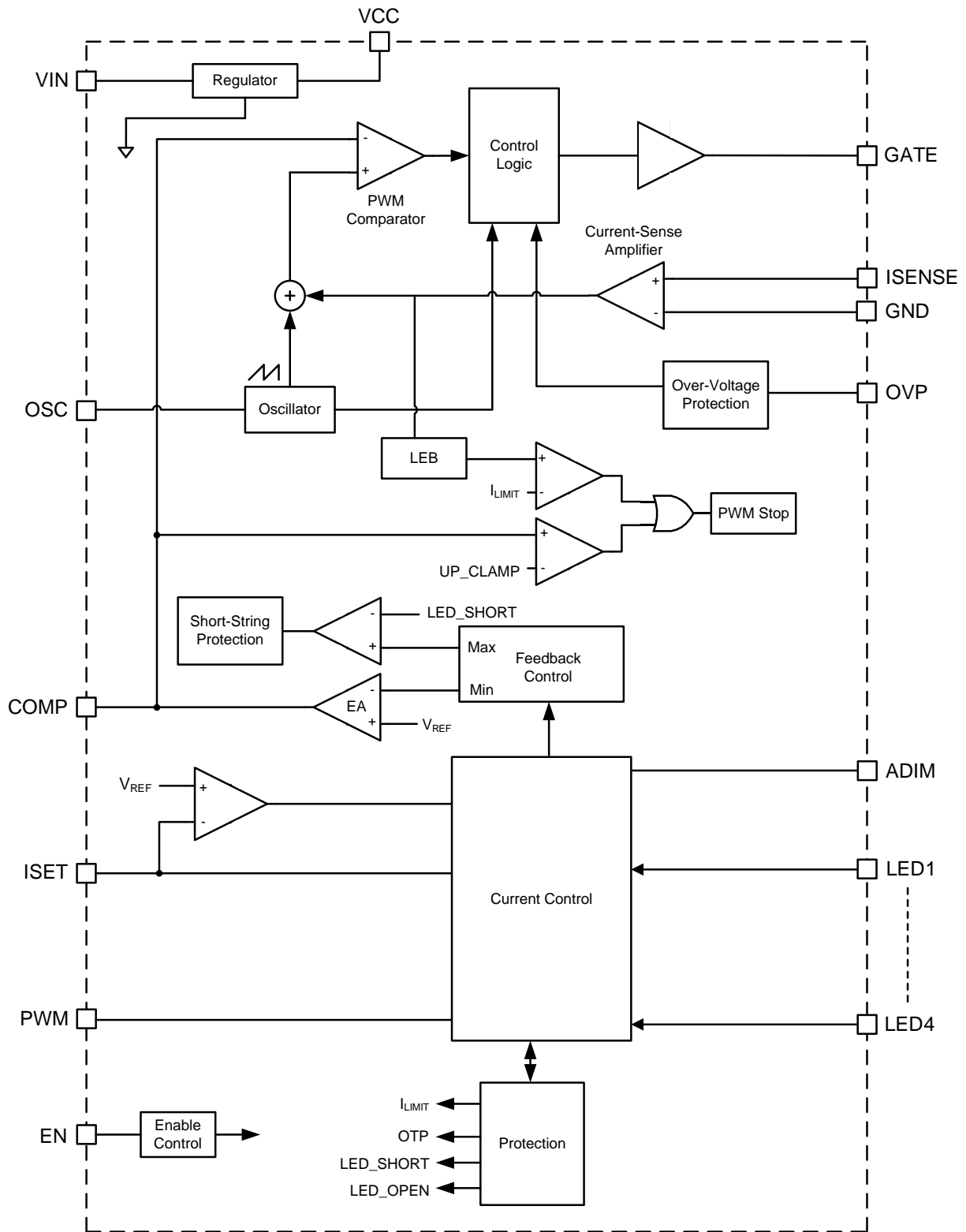
Diode Short Protection

Over-Temperature Protection

FUNCTIONAL BLOCK DIAGRAM

Figure 1: Functional Block Diagram

OPERATION

The MP3398H is a configurable, constant-frequency, peak current control mode, step-up converter with 4-channel regulated current sources to drive an array of up to four white LED strings.

Internal 5.9V Regulator

The MP3398H includes an internal linear regulator (VCC). When the input voltage (V_{IN}) exceeds 6.5V, VCC outputs a 5.9V power supply to the external MOSFET gate driver and the internal control circuitry. The VCC voltage (V_{CC}) drops to 0V when the chip shuts down. The MP3398H features under-voltage lockout (UVLO). The chip is disabled until V_{CC} exceeds the UVLO threshold. The UVLO hysteresis is approximately 350mV.

System Start-Up

When enabled, the MP3398H first checks the topology connection by monitoring the over-voltage protection (OVP) pin. This determines whether a Schottky diode is connected or the boost output is shorted to GND. An OVP voltage exceeding 55mV allows the chip to switch normally. Otherwise, switching is disabled. The MP3398H checks additional safety limits after passing the OVP test, including UVLO, over-temperature protection (OTP), and over-current protection (OCP). If all protection tests pass, then the chip begins boosting the step-up converter with an internal soft start (SS).

To prevent a large inrush current, it is recommended to apply the enable signal after establishing V_{IN} and the pulse-width modulation (PWM) dimming signal during the start-up sequence.

Step-Up Converter

At the beginning of each switching cycle, the internal clock turns on the external MOSFET. During normal operation, the minimum turn-on time for the external MOSFET is about 150ns. Add a stabilizing ramp to the current-sense amplifier's output to prevent subharmonic oscillations when the duty cycle exceeds 50%. Then the summed output of the stabilizing ramp and current-sense amplifier is fed into the PWM comparator. When the summed voltage

reaches the error amplifier (EA)'s output voltage (V_{COMP}), the external MOSFET turns off.

V_{COMP} is an amplified signal of the difference between the reference voltage (V_{REF}) and the feedback voltage (V_{FB}). The converter automatically chooses the lowest active LEDx pin voltage (V_{LEDx}) to provide a sufficient bus voltage to power all the LED arrays.

If V_{FB} drops below V_{REF} , then V_{COMP} increases. This results in more current flowing through the MOSFET, increasing the power delivered to the output and forming a closed loop that regulates the output voltage (V_{OUT}).

Under light-load operation, especially if $V_{OUT} \approx V_{IN}$, the converter runs in pulse-skip mode. In this mode, the MOSFET turns on for a minimum on time and then the converter discharges the power to the output for the remaining period. The external MOSFET remains off until V_{OUT} must be boosted again.

Dimming Control

The MP3398H provides three flexible dimming methods: direct PWM dimming, analog dimming with a PWM input, and analog dimming with a DC input.

For direct PWM dimming, pull the ADIM pin high to VCC, then apply a PWM signal to the PWM pin. The LED current (I_{LED}) is chopped by the PWM signal, and the average I_{LED} is equal to $I_{SET} \times D_{DIM}$, where D_{DIM} is the PWM dimming signal duty cycle, and I_{SET} is the I_{LED} amplitude set by a resistor between ISET and GND.

For analog dimming with a PWM input, connect a capacitor between ADIM and GND, then apply a PWM signal to PWM. An internal 100k Ω resistor combined with an external capacitor form the filter that is used to obtain the I_{LED} amplitude reference. The I_{LED} amplitude is equal to $I_{SET} \times D_{DIM}$, where D_{DIM} is the PWM dimming signal duty cycle, and I_{SET} is the I_{LED} amplitude set by a resistor between ISET and GND. A minimum 20kHz PWM signal is recommended to improve filtering.

For analog dimming with a DC input, pull PWM high to VCC or pull PWM down to GND,

then apply a 0V to 1.5V DC voltage on ADIM to adjust the I_{LED} amplitude from 0% to 100%.

Operating Switching Frequency (f_{sw})

The MP3398H's switching frequency (f_{sw}) is set via an external resistor (R_{OSC}) on OSC, which optimizes the size of the external components and system efficiency.

Open-String Protection

Open-string protection is achieved by detecting the OVP pin voltage and V_{LEDx} (where "LEDx" can be LED1, LED2, LED3, or LED4). If one or more strings are open, then the respective LEDx pins are pulled to ground, and the IC continues charging V_{OUT} until it reaches the OVP threshold. If the OVP threshold is triggered, then the chip stops switching and marks off the strings for which V_{LEDx} is below 200mV. Once marked, the remaining LED strings force V_{OUT} back to normal regulation. The string with the largest voltage drop determines the output regulation value.

The MP3398H always attempts to light at least one string. If all strings are open, the MP3398H shuts down the step-up converter. The strings remain in this marked state until the chip resets.

Short-String Protection

The MP3398H monitors V_{LEDx} to determine whether a short-string fault has occurred. If one or more strings are shorted, then the respective LEDx pins tolerate high-voltage stress. If V_{LEDx} exceeds the protection threshold, then short-string fault protection is triggered. When a short-string fault remains for 10ms, the fault

string is marked off and disabled. Once a string is marked off, it disconnects from the V_{OUT} loop until V_{IN} or EN restarts.

To prevent mistriggering an LED short protection when the LED string is open, the LED short protection function is disabled when all the used LED channels' V_{LEDx} exceeds 2.1V.

Cycle-by-Cycle Current Limit

To prevent the external components from exceeding their respective current stress ratings, the IC employs cycle-by-cycle current-limit protection. If the current exceeds the current limit threshold, the IC stops switching until the next clock cycle.

Short Inductor and Diode Protection

When the external inductor or diode is shorted, the IC provides protection by detecting the current flowing through the power MOSFET. Once the current-sense voltage across the current-sense resistor (R_{SENSE} , connected between ISENSE and GND) reaches the current protection threshold and lasts for eight switching cycles, the IC stops switching and latches off.

Thermal Shutdown

The MP3398H monitors the silicon die temperature to prevent the IC from operating at exceedingly high temperatures. If the die temperature exceeds the upper threshold (T_{ST}), the IC shuts down. Once the die temperature drops below the lower threshold, the IC starts up again and resumes normal operation. The typical hysteresis value is about 25°C.

APPLICATION INFORMATION

Selecting the Switching Frequency

The step-up converter's f_{SW} is recommended to be between 100kHz and 900kHz for most applications. R_{OSC} sets the internal f_{SW} for the step-up converter, which can be calculated with Equation (1):

$$f_{SW} \text{ (kHz)} = \frac{50000}{R_{OSC} \text{ (k}\Omega\text{)}} \quad (1)$$

For example, if R_{OSC} is set to 100k Ω , then f_{SW} is set to 500kHz.

Setting the LED Current

The current in each LED string is set via the current-setting resistor on ISET (R_{ISET}). I_{LED} can be calculated with Equation (2):

$$I_{LED} \text{ (mA)} = \frac{1200}{R_{ISET} \text{ (k}\Omega\text{)}} \quad (2)$$

If R_{ISET} is set to 12k Ω , then I_{LED} is set to 100mA. Do not leave ISET open.

Selecting the Input Capacitor

The input capacitor (C_{IN}) reduces the surge current drawn from the input supply as well as the switching noise from the device. The C_{IN} impedance at f_{SW} should be below the input source impedance to prevent high-frequency switching current from passing through to the input. Ceramic capacitors with X5R or X7R dielectrics are recommended for their low-ESR and small temperature coefficients. For most applications, it is recommended to use a 4.7 μ F ceramic capacitor in parallel with a 220 μ F electrolytic capacitor.

Selecting the Inductor and Current-Sense Resistor

A larger-value inductor results in reduced ripple current and peak inductor current (I_{L_PEAK}), which reduces stress on the N-channel MOSFET. However, it also has a larger physical size, higher series resistance, and lower saturation current. Choose an inductor that does not saturate under the worst-case load conditions. Select the minimum inductance to ensure that the boost converter works in continuous conduction mode (CCM) with high efficiency and good EMI performance.

The required inductance (L) can be calculated with Equation (3):

$$L \geq \frac{\eta \times V_{OUT} \times D \times (1-D)^2}{2 \times f_{SW} \times I_{LOAD}} \quad (3)$$

Where I_{LOAD} is the LED load current, η is the efficiency, and D is the switching duty cycle.

D can be calculated with Equation (4):

$$D = 1 - \frac{V_{IN}}{V_{OUT}} \quad (4)$$

The switching current is used for peak current control mode. To avoid reaching the current limit, the voltage across the current-sense resistor (R_{SENSE}) must be below 80% of the current limit voltage (V_{SENSE}) in the worst-case scenario. R_{SENSE} can be calculated with Equation (5):

$$R_{SENSE} = \frac{0.8 \times V_{SENSE}}{I_{L_PEAK}} \quad (5)$$

I_{L_PEAK} can be calculated using Equation (6):

$$I_{L_PEAK} = \frac{V_{OUT} \times I_{LOAD}}{\eta \times V_{IN}} + \frac{V_{IN} \times (V_{OUT} - V_{IN})}{2 \times L \times f_{SW} \times V_{OUT}} \quad (6)$$

Selecting the Power MOSFET

The MP3398H can drive a wide variety of N-channel MOSFETS. The critical MOSFET selection parameters include maximum drain-to-source voltage (V_{DS_MAX}), maximum current (I_{D_MAX}), on resistance ($R_{DS(ON)}$), gate-source charge (Q_{GS}) and gate-drain charge (Q_{GD}), and total gate charge (Q_G).

Ideally, the off-state voltage across the MOSFET is equal to V_{OUT} . Consider the voltage spike when the MOSFET turns off, where V_{DS_MAX} should be 1.5 times greater than V_{OUT} .

The maximum current through the power MOSFET occurs at the minimum V_{IN} (V_{IN_MIN}) and the maximum output power. The maximum RMS current through the MOSFET (I_{RMS_MAX}) can be calculated using Equation (7):

$$I_{RMS_MAX} = I_{IN_MAX} \times \sqrt{D_{MAX}} \quad (7)$$

Where I_{IN_MAX} is the maximum input current and D_{MAX} is the maximum switching duty cycle.

D_{MAX} can be calculated with Equation (8):

$$D_{MAX} \approx \frac{V_{OUT} - V_{IN_MIN}}{V_{OUT}} \quad (8)$$

The MOSFET's current rating should be 1.5 times greater than I_{RMS_MAX} .

The MOSFET's $R_{DS(ON)}$ determines the conduction loss (P_{COND}), which can be calculated with Equation (9):

$$P_{COND} = I_{RMS}^2 \times R_{DS(ON)} \times k \quad (9)$$

Where k is the MOSFET's temperature coefficient.

The switching loss is related to Q_{GD} and Q_{GS1} , which determine the commutation time. Q_{GS1} is the charge between the threshold voltage and the plateau voltage when a driver charges the gate, and can be read in the V_{GS} vs. Q_G chart in the MOSFET datasheet. Q_{GD} is the charge during the plateau voltage.

These two parameters are required to estimate the turn-on and turn-off losses (P_{SW}), which can be calculated with Equation (10):

$$P_{SW} = \frac{Q_{GS1} \times R_G}{V_{DR} - V_{TH}} \times V_{DS} \times I_{IN} \times f_{SW} + \frac{Q_{GD} \times R_G}{V_{DR} - V_{PLT}} \times V_{DS} \times I_{IN} \times f_{SW} \quad (10)$$

Where V_{TH} is the threshold voltage, V_{PLT} is the plateau voltage, V_{DS} is the drain-source voltage, and R_G is the gate resistance.

R_G is recommended to be between 10Ω and 20Ω.

Note that calculating the switching loss is the most difficult part of loss estimation. Equation (10) provides a simplified equation. For more accurate estimates, the equation becomes much more complex.

Q_G is used to calculate the gate drive loss (P_{DR}), which can be calculated with Equation (11):

$$P_{DR} = Q_G \times V_{DR} \times f_{SW} \quad (11)$$

Where V_{DR} is the drive voltage.

Selecting the Output Capacitor

The output capacitor (C_{OUT}) keeps the V_{OUT} ripple small and ensures feedback loop stability. C_{OUT} impedance must be low at f_{SW} . Ceramic capacitors with X7R dielectrics are recommended for their low ESR characteristics. For most applications, a 4.7μF ceramic capacitor in parallel with a 22μF to 47μF electrolytic capacitor is sufficient.

Setting the Over-Voltage Protection (OVP) Threshold

Open-string protection is achieved through detecting the OVP pin voltage. In some cases, an LED string failure results in V_{FB} remaining at 0V. The MP3398H continues boosting V_{OUT} higher and higher. If V_{OUT} reaches the configured OVP threshold, then OVP is triggered.

To ensure that the chip functions properly, an appropriate V_{OVP} is required. The recommended OVP level is about 1.1 to 1.2 times greater than V_{OUT} for normal operation. V_{OVP} is set via a resistor divider from the output to the OVP pin, and can be calculated with Equation (12):

$$V_{OVP} = 2V \times \left(1 + \frac{R_{HIGH}}{R_{LOW}}\right) \quad (12)$$

Expanding LED Channels

The MP3398H can expand the number of LED channels by using two or three ICs in parallel. To connect two ICs for a total of eight LED strings, connect the master IC's VCC pins to the slave IC's VCC pins, which powers the slave IC internal logic circuitry. Connect the slave IC's COMP pins to the master IC's COMP pins to regulate the voltage of all eight LED strings. The slave IC's MOSFET driving signal is not used. The boost converter can only be driven by the master IC. Do not leave the slave IC's ISENSE pin floating; instead, connect it to ground. Apply the EN and DIM signals to both ICs.

PCB Layout Guidelines

Efficient PCB layout is critical to reduce EMI noise and achieve stable operation. For the best results, refer to Figure 2 and follow the guidelines below:

1. A high-frequency pulse current flows through the loop between the external MOSFET, output diode, C_{OUT} , and R_{SENSE} . Keep this loop as small and short as possible.
2. Separate the power ground and signal ground to reduce noise affection.
3. Connect the power ground and signal ground together. All logic signals refer to the signal ground.
4. Place the ceramic capacitors for VIN and VCC as close to the IC as possible.

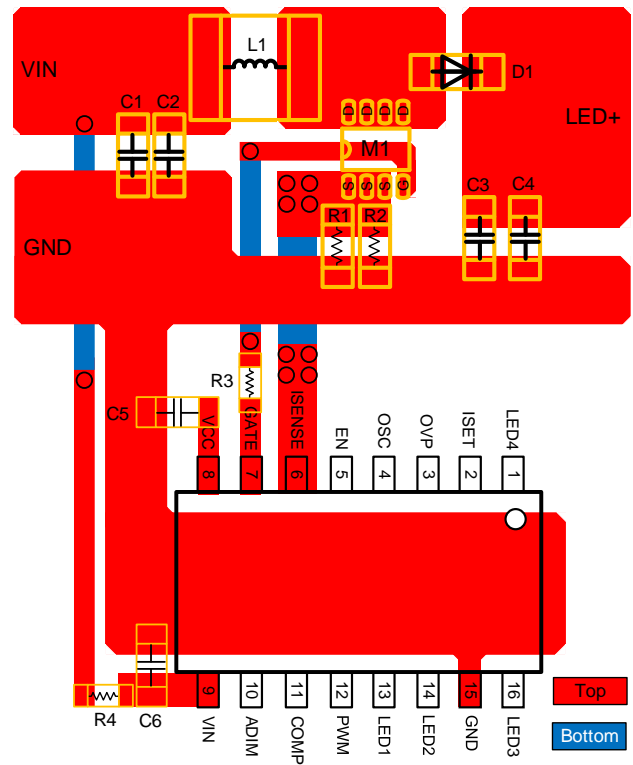

Figure 2: Recommended PCB Layout

TYPICAL APPLICATION CIRCUIT

Figure 3: Typical Application Circuit (4-String, 20 LEDs in Series, 120mA/String)

Note:

- 6) Some component values may need to be adjusted for different application conditions.

PACKAGE INFORMATION

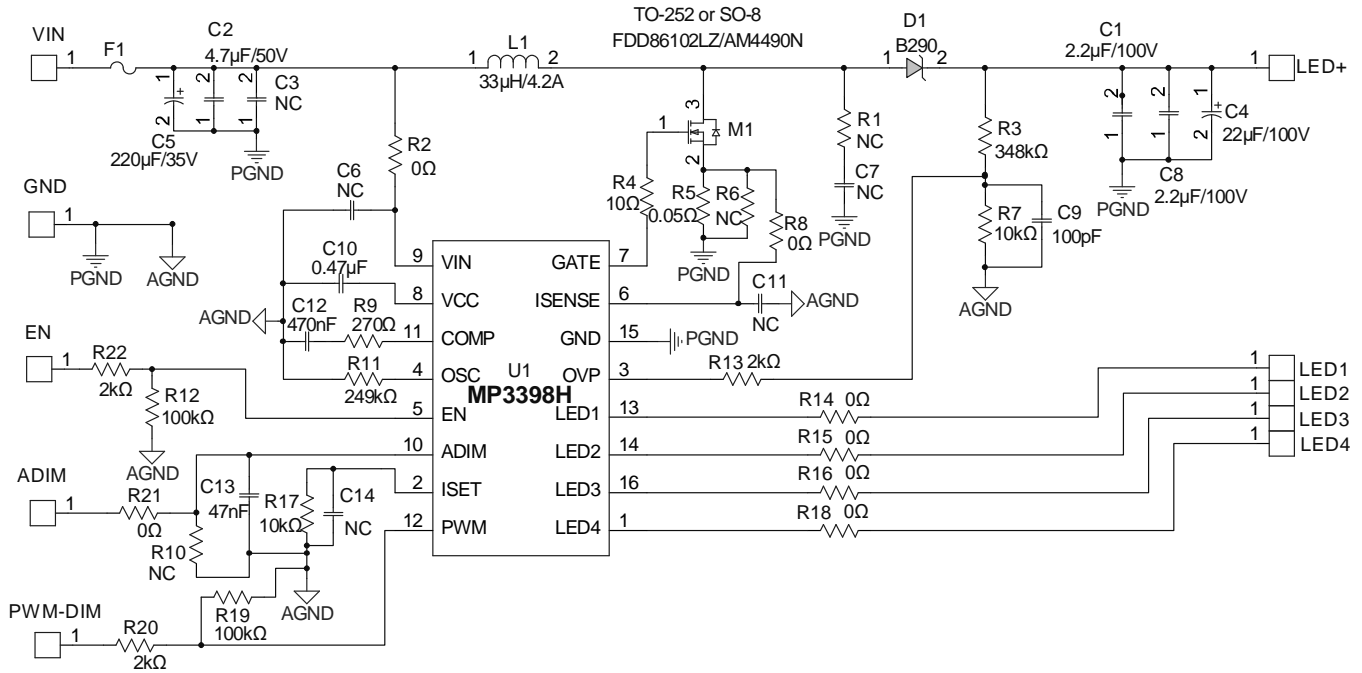
SOIC-16

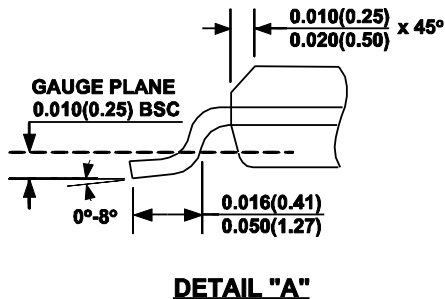
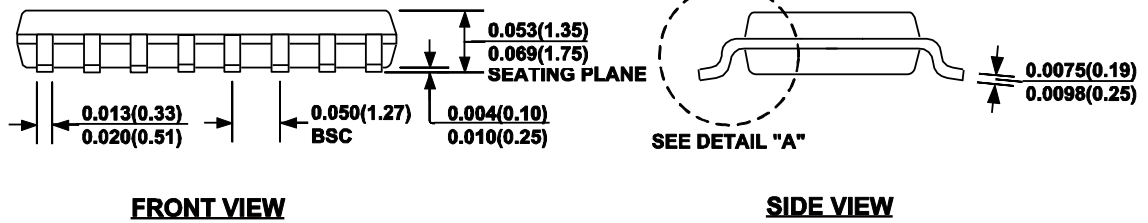
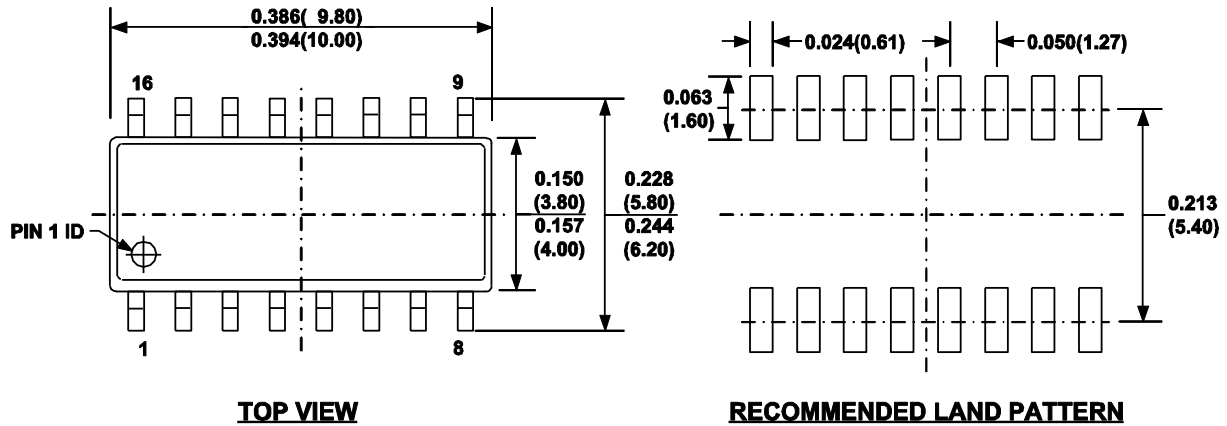
NOTE:

- 1) CONTROL DIMENSION IS IN INCHES. DIMENSION IN BRACKET IS IN MILLIMETERS.
- 2) PACKAGE LENGTH DOES NOT INCLUDE MOLD FLASH, PROTRUSIONS OR GATE BURRS.
- 3) PACKAGE WIDTH DOES NOT INCLUDE INTERLEAD FLASH OR PROTRUSIONS.
- 4) LEAD COPLANARITY (BOTTOM OF LEADS AFTER FORMING) SHALL BE 0.004" INCHES MAX.
- 5) DRAWING CONFORMS TO JEDEC MS-012, VARIATION AC.
- 6) DRAWING IS NOT TO SCALE.

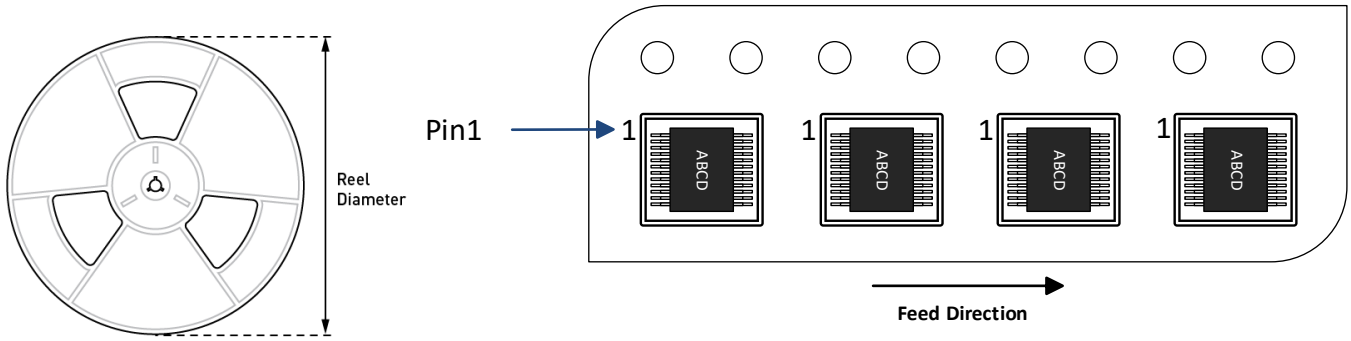
CARRIER INFORMATION

Part Number	Package Description	Quantity/ Reel	Quantity/ Tube	Quantity/ Tray	Reel Diameter	Carrier Tape Width	Carrier Tape Pitch
MP3398HGS-Z	SOIC-16	2500	50	N/A	13in	16mm	8mm

REVISION HISTORY

Revision #	Revision Date	Description	Pages Updated
1.0	9/16/2022	Initial Release	-

Notice: The information in this document is subject to change without notice. Please contact MPS for current specifications. Users should warrant and guarantee that third-party Intellectual Property rights are not infringed upon when integrating MPS products into any application. MPS will not assume any legal responsibility for any said applications.