



**RADIALL®**  
COAXIAL CONNECTORS

TECHNICAL DATA

R142.720.161

Issue : 9603

Page

FEMALE-FEMALE BULKHEAD ADAPTOR  
PACKAGING 100

Series : BNC 75 COM

1 / 1

without washer and screw nut

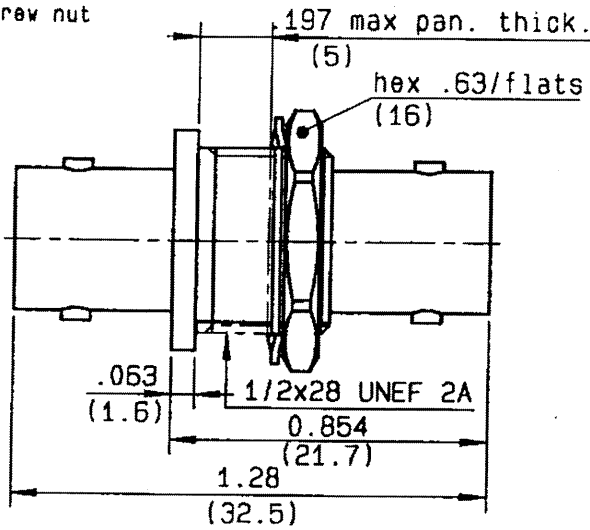
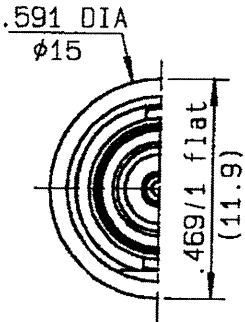

ROUND MOUNTING HOLE



	MM		INCH	
	min	max	min	max
A	12.7	12.8	.5	.504
C	12	12.1	.472	.476

CABLES : -

CHARACTERISTICS

NOMINAL IMPEDANCE	75	Ω
FREQUENCY RANGE	0-1.5	GHz
TEMPERATURE RATING	-35/+70	°C
VSWR	NA +	- x F(GHz)Max1
RF INSERTION LOSS	NA	√F(GHz) dB Max1
VOLTAGE RATING	500	Vrms Max
DIELECTRIC WITHSTANDING VOLTAGE	1500	Vrms min
INSULATION RESISTANCE	5000	MΩ min
HERMETIC SEAL	-	cc/s Atm.cm3/s
LEAKAGE (pressurized only)	NA	psi MPa
WEIGHT	0	Oz g

STANDARDISATION

CABLE RETENTION

CENTER CONTACT RETENTION

Axial force - mating end	3.37	lb min
Axial force - opposite end	3.37	lb min
Torque (Min)	0	inch.oz cm.N
Mating	0	inch.lb cm.N
Panel nut	32.74	inch.lb cm.N
Clamp nut	0	inch.lb cm.N

CONSTRUCTION

CONNECTOR PARTS	MATERIALS	FINISH
BODY	ZAMAK	80μI NICKEL
OUTER CONTACT	-	-
CENTER CONTACT	BRASS	8μI GOLD OVER 80μI NICKEL
INSULATOR	PTFE	-
WASHER	COPPER	80μI NICKEL
NUT	BRASS	80μI NICKEL
-	-	-
-	-	-
-	-	-

ISSUE	REVISION No	DESCRIPTION	BY	DATE
-	-	-	-	-
-	-	-	-	-
-	-	-	-	-

Initiated on 18/01/96

The information given here is subject to change without notice. Design changes may be in order to improve the product.



Approval by -

Y.PERRIN

93-0105-027