

SPECIFICATION FOR APPROVAL

承 認 書

Description : Piezo Transducer

Kingstate Part No. : KMTG1909L

Customer's Model No. : _____

Specification No. : DOD-U942

Number Of The Edition : 1.1

CUSTOMER'S APPROVED SIGNATURE		

 **KINGSTATE 志豐電子股份有限公司 KINGSTATE ELECTRONICS CORP.**

Address: 10F, No. 69-11, Sec. 2, Chung Cheng E. Rd., Tamshui County, Taipei-Hsien, Taiwan, R.O.C.

International sales dept.: TEL: 886-2-2809-5651 FAX: 886-2-2809-7151

Domestic sales dept.: TEL: 886-2-2809-0668 FAX: 886-2-28096748

<http://www.kingstate.com.tw>

Approved by	Checked by	Issued by
		ZHUXIAOLEI 2023/03/30

A.SCOPE 範疇

This specification applies piezo transducer, **KMTG1909L**
此規格書適用於壓電式蜂鳴器, **KMTG1909L**

B. SPECIFICATION 規格

No.	Item	Unit	Specification	Condition
1	Max Operating Volt 最大操作電壓	Vp-p	MAX18	
2	Current consumption 消耗電流	mA	MAX 15	at 12Vp-p, square wave, 2.0KHz. Measure by FLUKE 87
3	Sound pressure level 輸出音壓	dB	MIN 88	at 10cm/12Vp-p, square wave, 2.0KHz
4	Electrostatic capacity 靜電容量	pF	35,000 ± 30%	at 100Hz/1V
5	Operating temp. 操作溫度	°C	-40~ +85	
6	Storage temp. 儲存溫度	°C	-40~+85	
7	Dimension 尺寸	mm	19.0*19.0*8.5	See appearance drawing 請參照外觀尺寸圖
8	Weight (MAX) 重量	gram	2.0	
9	Material 材質		LCP(黑)	
10	Terminal 端子		SMD Type(Plating Sn)	See appearance drawing 請參照外觀尺寸圖
11	Environmental Protection Regulation 環保法規		RoHS 2.0	
12	Storage life 保存期限	month	6	6 months preservation at room temp.(25±3°C), Humidity40% 在室溫下 25±3°C, 濕度 40% 以下可保存 6 個月.
13	MSL 濕敏指數		2a	≤30°C/60%RH 4 weeks Floor life 小於或等於 30°C/60%RH 4 周車間壽命

Number of the patent: CN208477910U (CN), M569487(TW)

C. APPEARANCE DRAWING 外觀尺寸圖

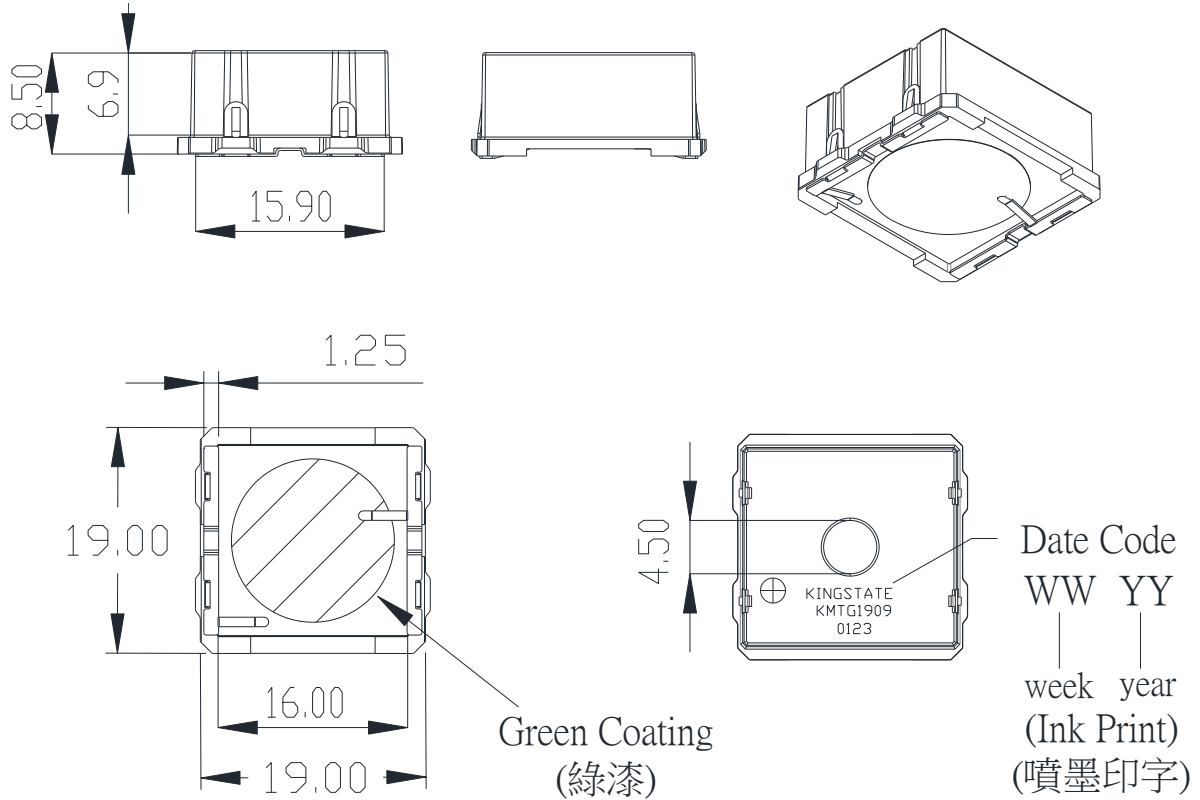

Tol:±0.5
Unit : mm

D. MEASURING METHOD 測量方法

1. S.P.L. Measuring Circuit 音壓測試接線圖

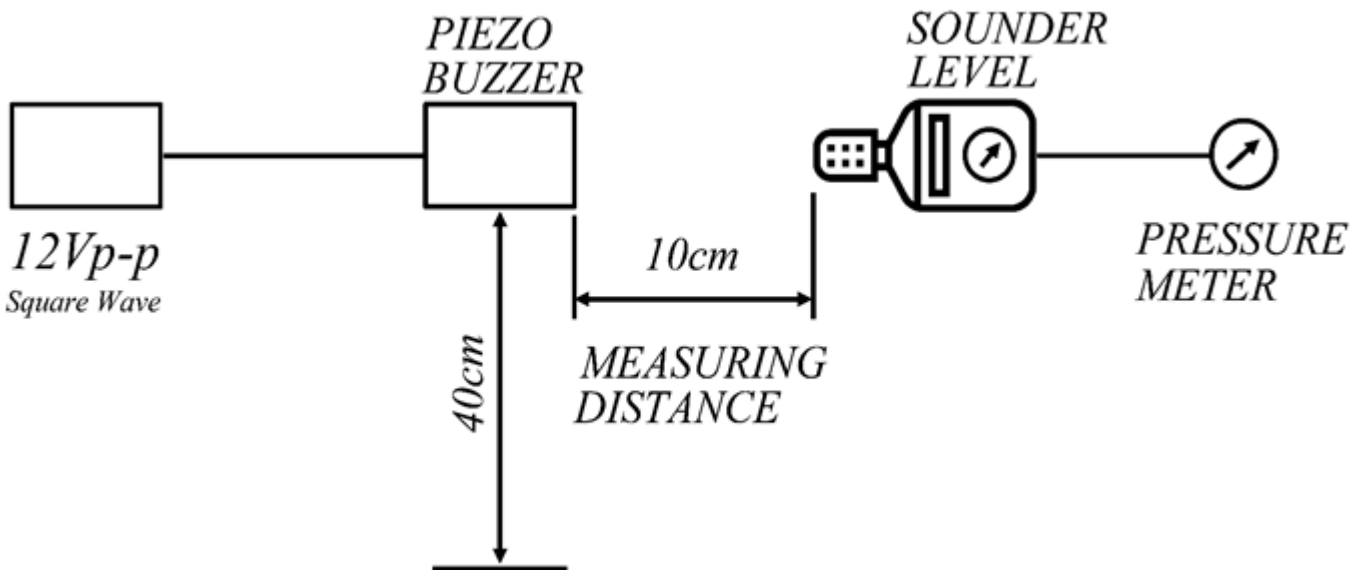

Mic : RION S.P.L. meter UC30 or equivalent
Mic : RION 噪音計 UC30 或同等品

E. TYPICAL FREQUENCY RESPONSE CURVE 頻率響應曲線

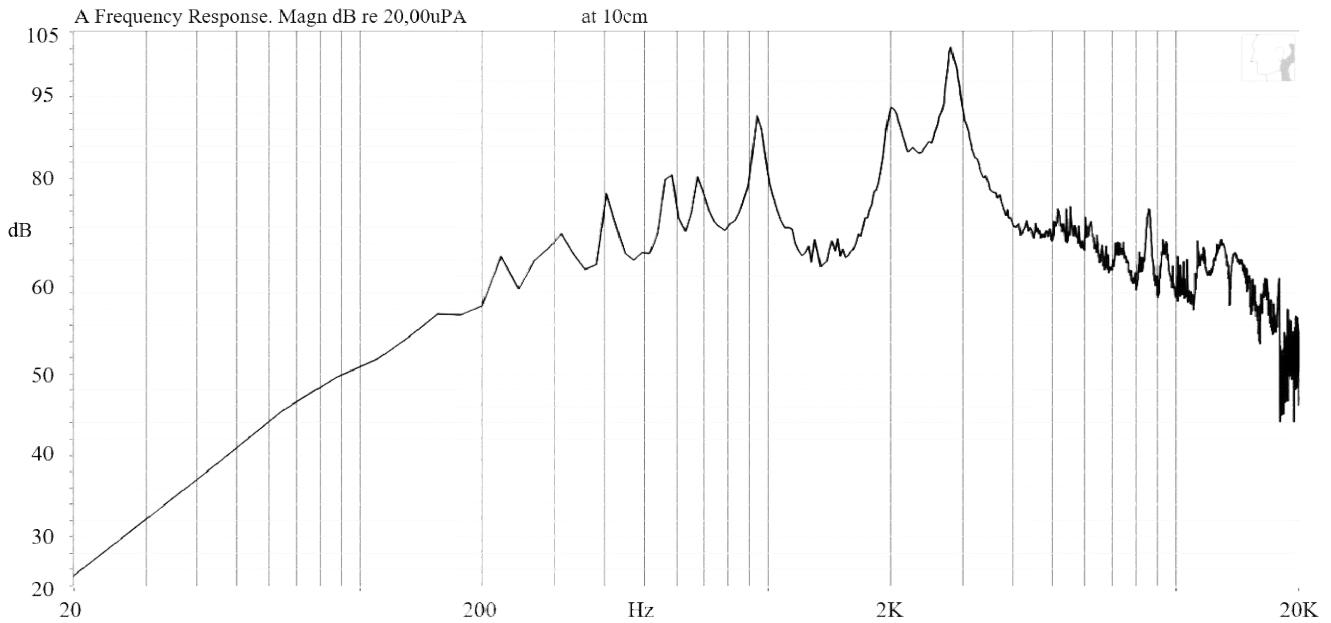

F. MECHANICAL CHARACTERISTICS 機械特性

No.	Item	Test Condition	Evaluation standard
1	Solderability 焊錫附著性	Lead terminals are immersed in rosin for 5 seconds and then immersed in solder bath of $+270\pm 5^{\circ}\text{C}$ for 3 ± 1 seconds. 端子部份浸入松香溶液 5 秒後,再浸入 $+270\pm 5^{\circ}\text{C}$ 熔融焊錫槽中 3 ± 1 秒.	90% min. lead terminals shall be wet with solder. (Except the edge of terminal) 浸入端子部份附著焊錫 90% 以上.(末端斷面不算)
2	Soldering Heat Resistance 焊錫耐熱性	The product is followed the reflow temperature curve to test its reflow thermostability. 產品依照回焊溫度曲線測試回焊耐熱性.	No interference in operation 操作上無任何不良.
3	Vibration 振動試驗	Buzzer shall be measured after being applied vibration of amplitude of 1.5mm with 10 to 55hz band of vibration frequency to each of 3 per-pendicular directions for 2 hours. 振動週波數 10~55HZ、全振幅 1.5mm 於 X.Y.Z 3 個方向,各 2 小時.	The value of oscillation frequency/ current consumption should be in 10% compared with initial ones .The SPL should be in $\pm 10\text{dB}$ compared with initial one.
4	Drop test 落下測試	The part only shall be dropped from a height of 75cm onto a 40mm thick wooden board 3 times in 3 axes (X.Y.Z). (a total of 9 times). 單體從 75 公分高處, X.Y.Z.3 個方向,各 3 回,落於 40mm 厚木板上.	諧振頻率與消耗電流變化量須在 $\pm 10\%$ 內. 輸出音壓變化量須在 $\pm 10\text{dB}$ 內.

G. ENVIRONMENT TEST 環境測試

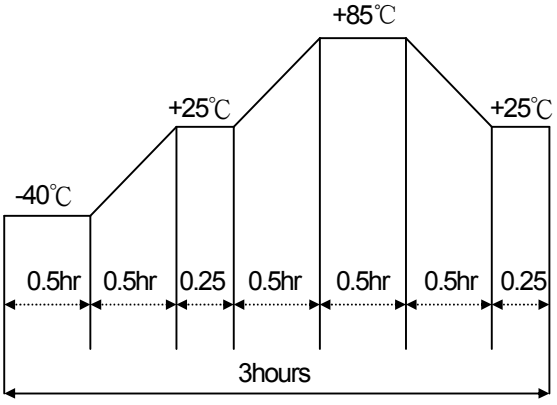
No	Item	Test Condition	Evaluation standard
1	High temp. test 高溫測試	After being placed in a chamber at +85°C for 96 hours 置於+85°C環境中 96 小時	Being placed for 4 hours at +25°C, buzzer shall be measured. The value of oscillation frequency/ current consumption should be in ±10% compared with initial ones .The SPL should be in ±10dB compared with initial one. 經測試後, 靜置於+25°C (室溫) 環境中 4 小時後, 諧振頻率與消耗電流變化量須在±10%內. 輸出音壓變化量須在±10dB 內.
2	Low temp. test 低溫測試	After being placed in a chamber with -40°C for 96 hours 置於-40°C 環境中 96 小時	
3	Humidity test 相對濕度測試	After being placed in a chamber at +40°C and 90±5% relative humidity for 96 hours 置於+40°C, 相對濕度 90±5% 環境中 96 小時	
4	Temp. cycle test 溫度循環試驗	The part shall be subjected to 5 cycles. One cycle shall be consist of: 單體承受溫度循環測試 5 次, 其循環內容如圖示: 	

H. RELIABILITY TEST 信賴性測試

No.	Item	Test condition	Evaluation standard
1	Operating lifetest 壽命測試	1.Continuous life test 高溫壽命測試(連續) 72 hours continuous operation at +70°C with rated voltage applied. 在+70°C環境下, 以額定電壓連續操作 72 小時. 2.Intermittent life test 室溫壽命測試(間歇) A duty cycle of 1 minute on, 1 minutes off, a minimum of 5000 times at room temp.(+25 ±2°C)and rated voltage applied 在室溫下(+25 ±2°C), 以額定電壓操作, 通電 1 分鐘/斷電 1 分鐘, 測試 5000 次循環.	Being placed for 4 hours at +25°C, buzzer shall be measured. The value of oscillation frequency/ current consumption should be in ±10% compared with initial ones .The SPL should be in ±10dB compared with initial one. 經測試後, 靜置於+25°C (室溫) 環境中 4 小時後, 諧振頻率與消耗電流變化量須在±10%內. 輸出音壓變化量須在±10dB 內.

TEST CONDITION.

Standard Test Condition	:	a) Temperature: +5 ~ +35°C b) Humidity: 45-85% c) Pressure: 860-1060mbar
一般測試條件	:	a) 溫度: +5 ~ +35°C b) 濕度: 45-85% c) 氣壓: 860-1060mbar
Judgement Test Condition	:	a) Temperature: +25 ± 2°C b) Humidity: 60-70% c) Pressure: 860-1060mbar
爭議時測試條件	:	a) 溫度: +25 ± 2°C b) 濕度: 60-70% c) 氣壓: 860-1060mbar

I. Recommended Temperature Profile for Reflow Oven 推薦迴流焊曲線

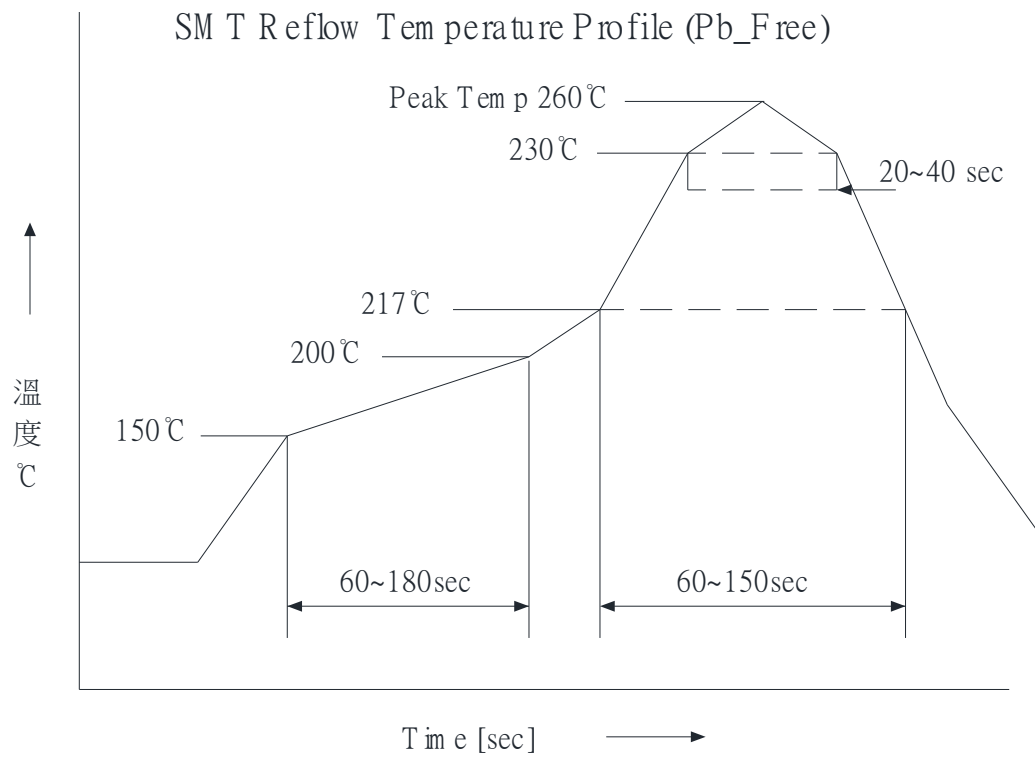

*Reflow can't over 1 time. 迴流焊次數不超過 1 次.

J. Recommended land pattern 建議基板設計尺寸

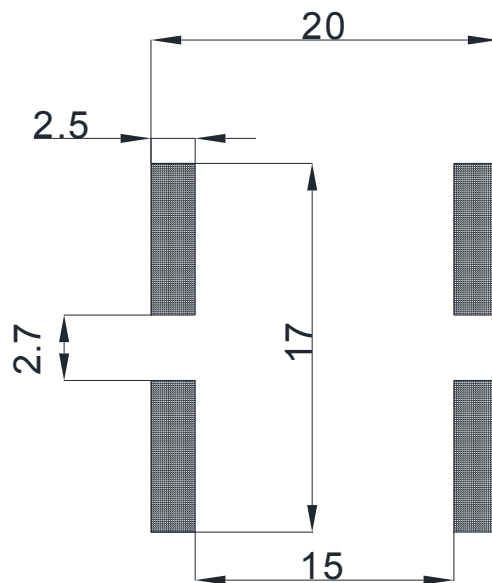

K.PACKING STANDARD 包裝規格

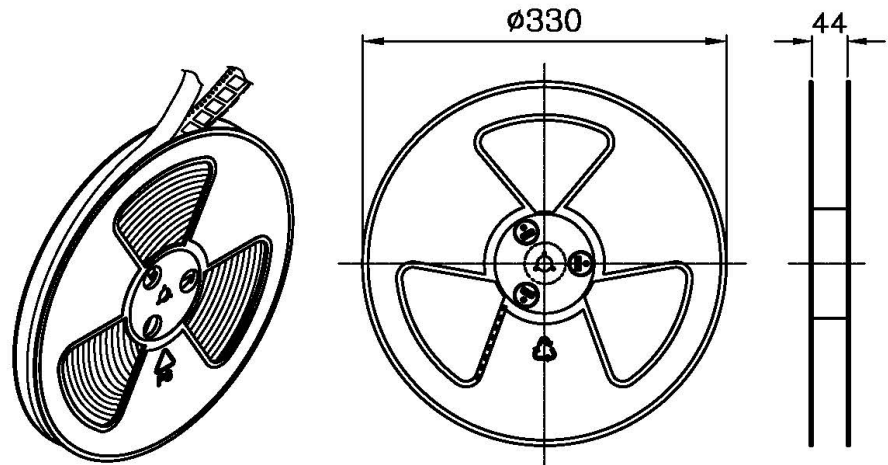

1 Reel : 200PCS

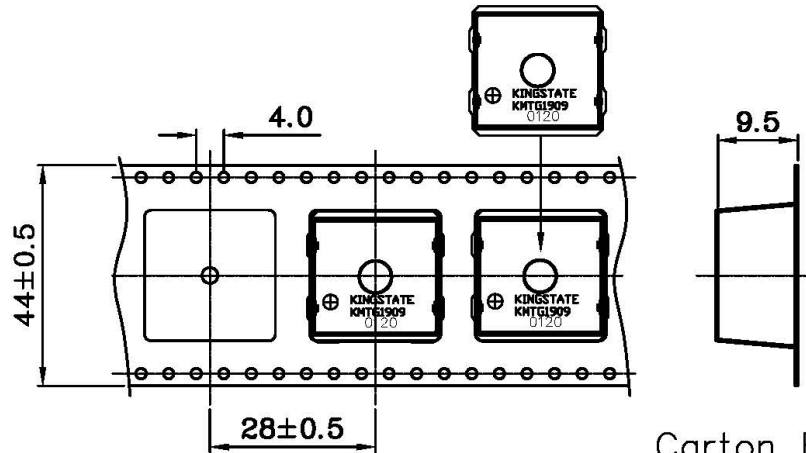

Carton Box
(5 Inner Box)

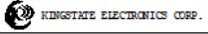
Lot No.	XXXXXXXXXX
Part No.	XXXXXXXXXX
Quantity	XXXX Pcs
Date	
WWYY	
	

* The label sticked on inner boxes and the outer of carton.



真空包裝袋/內附干燥剂/HIC 卡
MSD 标签/符合 MSL-2a

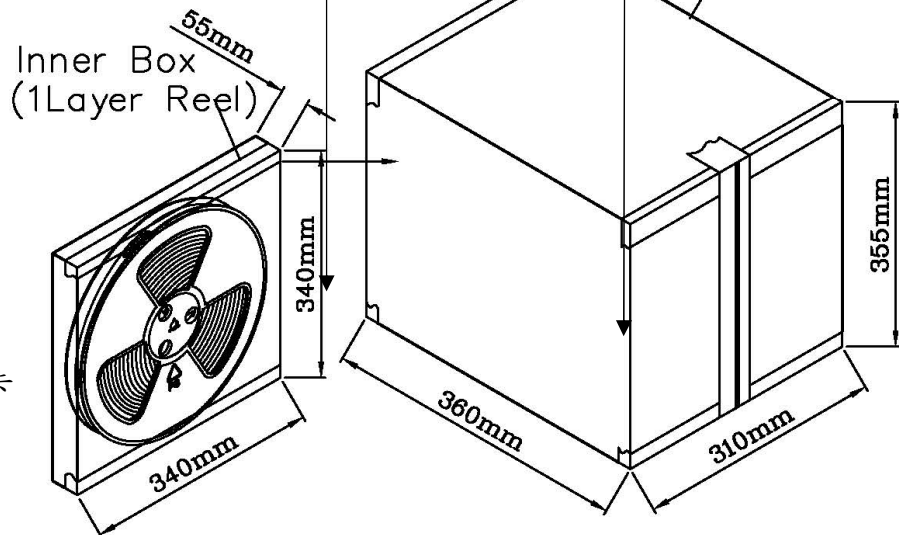

Inner Box	340mmx340mmx55mm	1x200PCS=200PCS
Carton Box	360mmx310mmx355mm	5x200PCS=1000PCS