

- Conduction cooled design approach
- Operating temperature range -30°C to $+80^{\circ}\text{C}$
- I/O reinforced isolation 4250 VAC
- Over voltage category (OVC III)
- High efficiency up to 92%
- Operating up to 5000 m altitude
- Internal EN 55032 class B filter
- Protection class II prepared
- 3 year product warranty



The TCI 500 is a 500 Watt conduction cooled AC/DC enclosed power supplies series with a 4250 VAC reinforced isolation system. Traco Power's new TCI line focuses on maximizing the proficiency of conduction cooled systems as it offers superior temperature behavior when mounted on a metal chassis or baseplate. Excellent efficiency of up to 92% allows the TCI series to operate from -30 to $+50^{\circ}\text{C}$ without derating, while going up to $+80^{\circ}\text{C}$ with either load derating or forced cooling. They also meet OVC III requirements and can operate at up to 5000 m altitude. Active power factor correction, EMC characteristics dedicated for applications in industrial/automation and test & measurement fields and high reliability make the new TCI line an ideal solution for any demanding industrial application.

Models

Order Code	Output Power max.	Output Voltage nom. (adjustable)	Output Current max.	Efficiency typ.
TCI 500-112-T	500 W	12 VDC (11.4 - 12.6 VDC)	41'500 mA	90 %
TCI 500-124-T		24 VDC (22.8 - 25.2 VDC)	20'800 mA	91 %
TCI 500-148-T		48 VDC (45.6 - 50.4 VDC)	10'410 mA	92 %

Options

TCI-AC1	- Optional Cable: www.tracopower.com/products/tci-ac1.pdf
TCI500-AUX	- Optional Cable: www.tracopower.com/products/tci500-aux.pdf

Input Specifications

Input Voltage	- AC Range	Operational Range: 90 - 264 VAC (Full Range) Rated Range: 100 - 240 VAC (Full Range)
	- DC Range	Operational Range: 127 - 370 VDC (Designed for, no certification) Polarity: irrelevant
Input Frequency		Operational Range: 47 - 63 Hz Certified: 50/60 Hz
Input Current	- Full Load & Vin = 230 VAC - Full Load & Vin = 115 VAC	3'150 mA max. 6'300 mA max.
Power Consumption	- No load & Vin = 230 VAC - No load & Vin = 115 VAC	500 mW max. (Ready to meet ErP directive) 500 mW max.
Input Inrush Current	- At 230 VAC - At 115 VAC	80 A max. 40 A max.
Power Factor	- At 230 VAC - At 115 VAC	0.94 min. (Active Power Factor Correction) 0.94 min. (Active Power Factor Correction)
Input Protection		T 10 A / 250 VAC (Internal Fuse in L & N)
Recommended Input Fuse		(The need of an external fuse has to be assessed in the final application.)

Output Specifications

Output Voltage Adjustment		±5% (By trim potentiometer) Output power must not exceed rated power!
Voltage Set Accuracy		±2% max.
Regulation	- Input Variation (Vmin - Vmax) - Load Variation (0 - 100%)	1% max. 1% max.
Ripple and Noise (20 MHz Bandwidth)		12 VDC model: 160 mVp-p max. (w/ 0.1 µF ceramic 47 µF KY) 24 VDC model: 240 mVp-p max. (w/ 0.1 µF ceramic 47 µF KY) 48 VDC model: 480 mVp-p max. (w/ 0.1 µF ceramic 47 µF KY)
Capacitive Load		12 VDC model: 5'000 µF max. 24 VDC model: 2'500 µF max. 48 VDC model: 1'250 µF max.
Minimum Load		Not required
Temperature Coefficient		±0.06 %/K max. (-30°C - 0°C) ±0.03 %/K max. (0°C - 50°C)
Hold-up Time	- At 230 VAC - At 115 VAC	5 ms min. 8 ms min.
Start-up Time	- At 230 VAC - At 115 VAC	350 ms max. 350 ms max.
Short Circuit Protection		Continuous, Automatic recovery (Level 1, nom.) Latch (Level 2, instantaneous high current)
Output Current Limitation		113 - 161% of Iout max.
Overvoltage Protection		111 - 130% of Vout nom.
Transient Response	- Response Deviation - Response Time	3% typ. / 5% max. (25% to 100% Load Step) 2'000 µs typ. / 3'000 µs max. (25% to 100% Load Step)

Safety Specifications

Safety Standards	- IT / Multimedia Equipment	EN 62368-1 IEC 62368-1 UL 62368-1
	- Certification Documents	www.tracopower.com/overview/tci500
Protection Class		Class I (Prepared): Connection to PE
Pollution Degree		PD 2

All specifications valid at nominal voltage, resistive full load and +25°C after warm-up time, unless otherwise stated.

EMC Specifications

EMI Emissions	- Conducted Emissions	EN 55032 class B (internal filter)
	- Radiated Emissions	EN 55032 class B (internal filter)
	- Harmonic Current Emissions	EN 61000-3-2, class A
EMS Immunity	- Electrostatic Discharge	Air: EN 55035 (Multimedia) EN 61000-4-2, ±8 kV, perf. criteria A Contact: EN 61000-4-2, ±4 kV, perf. criteria A
	- RF Electromagnetic Field	EN 61000-4-3, 3 V/m, perf. criteria A
	- EFT (Burst) / Surge	EN 61000-4-4, ±1 kV, perf. criteria A
	- Conducted RF Disturbances	L to L: EN 61000-4-5, ±1 kV, perf. criteria A
	- PF Magnetic Field	L to PE: EN 61000-4-5, ±2 kV, perf. criteria A
	- Voltage Dips & Interruptions	Continuous: EN 61000-4-6, 3 Vrms, perf. criteria A 230 VAC / 50 Hz: EN 61000-4-8, 1 A/m, perf. criteria A EN 61000-4-11 30%, 25 periods, perf. criteria A >95%, 250 periods, perf. criteria B 115 VAC / 60 Hz: 30%, 25 periods, perf. criteria A >95%, 250 periods, perf. criteria B

General Specifications

Relative Humidity		95% max. (non condensing)
Temperature Ranges	- Operating Temperature	-30°C to +70°C
	- Storage Temperature	-30°C to +85°C
Power Derating	- High Temperature	2 %/K above 50°C
	- Low Input Voltage	3 %/V below 100 VAC
		See application note: www.tracopower.com/overview/tci500
Over Temperature Protection Switch Off	- Protection Mode	115°C min. / 120°C typ. / 125°C max. (Automatic recovery at 90°C typ.)
	- Measurement Point	Internal IC temperature
Cooling System		Forced air cooling (with internal fan)
Fan Power Source	- Output Voltage	12 VDC
	- Output Current	209 mA max. (Fan output voltage: 10.2 - 13.3 VDC when main output load > 3% and fan current > 0.1 mA)
Standby Power Source	- Output Voltage	5 VDC
	- Output Current	1 A max.
Remote Control	- Voltage Controlled Remote	On: 3.3 to 5 VDC or open circuit Off: 0 to 1.0 VDC or short circuit Refers to '+Remote' and '-Remote' Pin
	- Off Idle Input Current	92 mA typ. / 210 mA max.
	- Remote Pin Input Current	10 to 30 mA
Altitude During Operation		4'000 m max. (for OVC III) 5'000 m max. (for OVC II)
Switching Frequency		58 - 76 kHz (PFM) 67 kHz typ. (PFM)
Insulation System		Reinforced Insulation
Isolation Test Voltage	- Input to Output, 60 s	4'250 VAC (6'000 VDC)
	- Input to Case or PE, 60 s	2'830 VAC (4'000 VDC)
	- Output to Case or PE, 60 s	1'500 VAC (2'121 VDC)
Isolation Resistance	- Input to Output, 500 VDC	100 MΩ min.
Leakage Current (at 264 VAC / 50 Hz)	- Earth Leakage Current	1500 μA max.
	- Touch Current	1500 μA max.
Distance Through Isolation		7.1 mm
Reliability	- Calculated MTBF	160'000 h (MIL-HDBK-217F, ground benign)
Washing Process		Not allowed

All specifications valid at nominal voltage, resistive full load and +25°C after warm-up time, unless otherwise stated.

Environment	- Vibration - Mechanical Shock	IEC 60068-2-6 2 g, 3 axis, 60 min, 10-500 Hz, 10 min/cycle IEC 60068-2-27 50 g, 3 axis, half sine, 11 ms
Housing Material		Aluminum
Potting Material		Silicone (UL 94 V-0 rated) (the converter is partly potted on the bottom)
Housing Type		Metal Case
Mounting Type		Chassis Mount
Connection Type		Screw Terminal, Pin Connector
Weight		710 g
Power OK Signal	- Power OK - Power Off	Voltage source output High level Low level (Refers to 'PG' and 'GND' Pin)
Sense Function		3% max. of Vout nom.
Environmental Compliance	- REACH Declaration - RoHS Declaration - SCIP Reference Number	www.tracopower.com/info/reach-declaration.pdf REACH SVHC list compliant REACH Annex XVII compliant Exemptions: 7a, 7c-I (RoHS exemptions refer to the component concentration only, not to the overall concentration in the product (O5A rule.)) 1dab86cb-c6c6-4c4f-9524-9695b51a1299

Supporting Documents

Overview Link (for additional Documents)

www.tracopower.com/overview/tci500

All specifications valid at nominal voltage, resistive full load and +25°C after warm-up time, unless otherwise stated.

Outline Dimensions

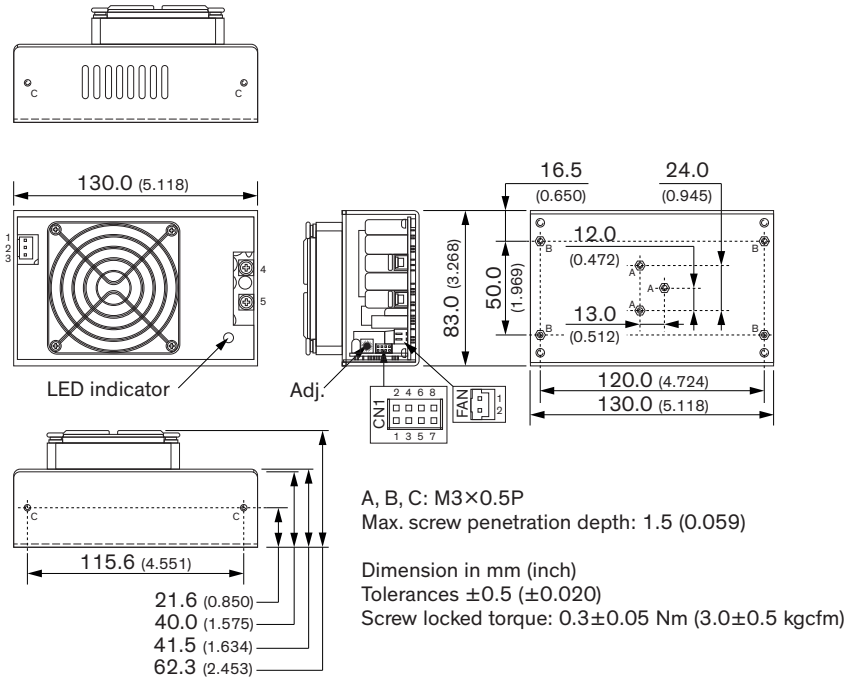

Input	
Pin	Function
1	AC (N)
2	No Pin
3	AC (L)

Output	
Pin	Function
4	+Vout
5	-Vout**

FAN	
Pin	Function
1	+12V
2	GND

Auxiliary	
CN1	
Pin	Function
1	+Standby
2	-Standby**
3	GND
4	Power Good
5	-Remote**
6	+Remote
7	-Sense**
8	+Sense

Case	
(no dedicated connector)	
Pos	Function
A	For mounting on chassis only
B	For mounting on PCB or chassis, and connecting PE
C	For connecting PE only

**Internally connected with GND

Input: JST series
 mates with JST crimp terminal: SVH-41T-P1.1 or Equivalent
 and terminal housing: VHR-3N or Equivalent

Output: Screw Terminal
 M3.5 Pozzi Pan Head Screw
 max. torque: 0.9 Nm (9.1 kgcfm)

Auxiliary: JST series
 mates with JST crimp terminal: SPHD-001T-P0.5 or Equivalent
 and terminal housing: PHDR-08VS or Equivalent

FAN: JST series
 mates with JST crimp terminal: SXH-002T-P0.6 or Equivalent
 and terminal housing: XHP-2 or Equivalent