

Photon 2 Datasheet

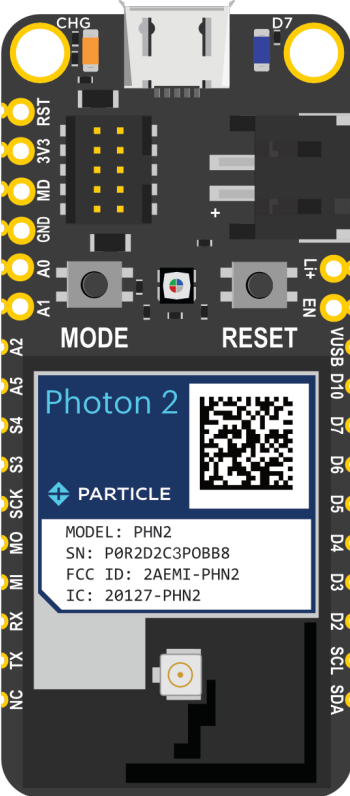

Functional description

OVERVIEW

The Photon 2 is a development module with a microcontroller and Wi-Fi networking. The form-factor is similar to the Argon (Adafruit Feather), but the Photon 2 supports 2.4 GHz and 5 GHz Wi-Fi, BLE, and has much larger RAM and flash that can support larger applications.

It is intended to replace both the Photon and Argon modules. It contains the same module as the P2, making it easier to migrate from a pin-based development module to a SMD mass-production module if desired.

FEATURES

- 802.11a/b/g/n Wi-Fi, 2.4 GHz and 5 GHz
 - Integrated PCB antenna
 - Integrated U.FL connector for external antenna
 - Integrated RF switch
- BLE 5 using same antenna as Wi-Fi
- Realtek RTL8721DM MCU
 - ARM Cortex M33 CPU, 200 MHz
- 2048 KB (2 MB) user application maximum size
- 3072 KB (3 MB) of RAM available to user applications
- 2 MB flash file system
- FCC, IC, and CE certified

DEVICE OS SUPPORT

The Photon 2 and P2 require Device OS 5.0.0 or later. It is recommended that you use the latest version in the 5.x release line.

For information on upgrading Device OS, see [Version information](#). For the latest version shipped from the factory, see [Manufacturing firmware versions](#) page. See also [Long Term Support \(LTS\) releases](#).

Interfaces

BLOCK DIAGRAM

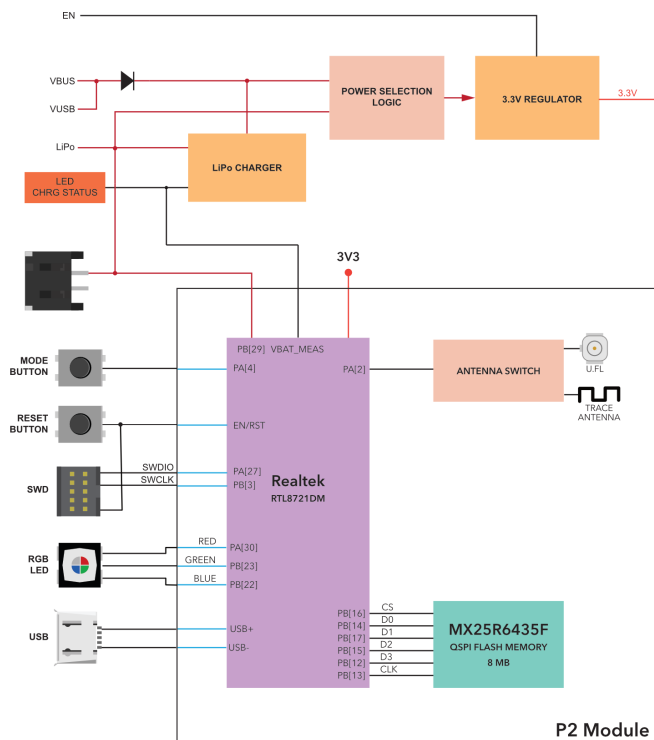

POWER

USB

The USB port is the easiest way to power up the Photon 2. Please make sure that the USB port is able to provide at least 500mA. The Photon 2 has a micro B connector, same as the Photon.

VUSB Pin

The pin is internally connected to the VBUS of the USB port. The nominal output should be around 4.5 to 5 VDC when the device is plugged into the USB port and 0 when not connected to a USB source. You can use this pin to power peripherals that operate at such voltages. Do not exceed the current rating of the USB port, which is nominally rated to 500mA. This pin is also protected with an internal fuse rated at 1000mA.

It is also possible to use the VUSB to power the Photon 2 if not using the USB port.

LiPo

If you want to make your projects truly wireless, you can power the device with a single cell LiPo (3.7V). The Photon 2 has an on board LiPo charger that will charge and power the device when USB source is plugged in or power the device from the LiPo alone in the absence of the USB.

NOTE: Please pay attention to the polarity of the JST-PH LiPo connector. Not all LiPo batteries follow the same polarity convention!

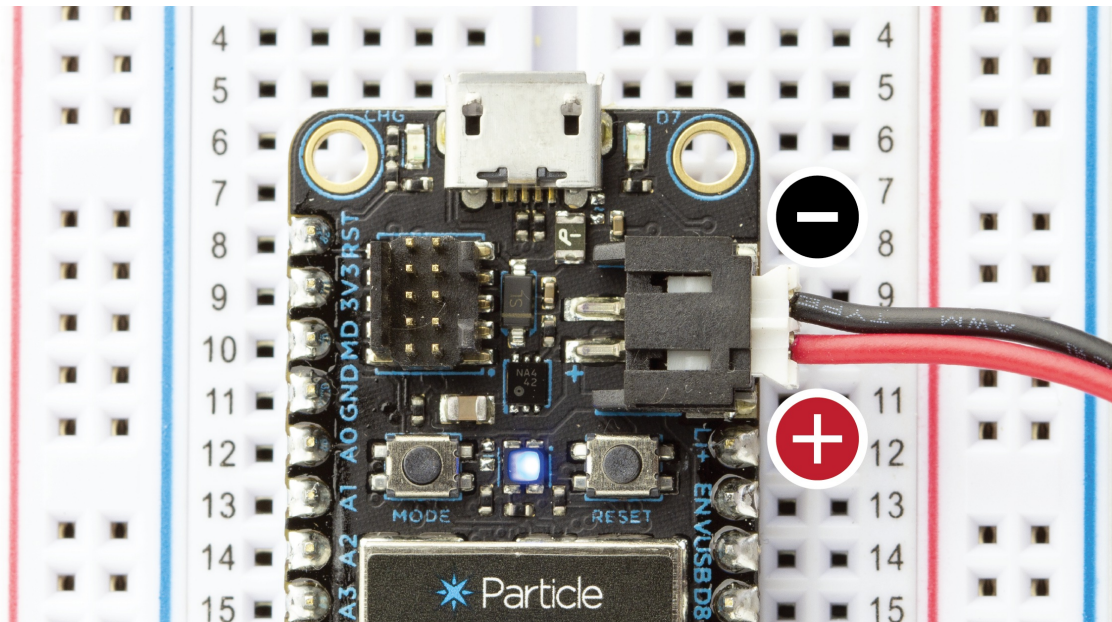

Li+ pin

This pin is internally connected to the positive terminal of the LiPo connector. You can connect a single cell LiPo/Lithium Ion or a DC supply source to this pin for powering the Photon 2. Remember that the input voltage range on this pin is 3.6 to 4.2 VDC.

3V3 PIN

This pin is the output of the on board 3.3V step-down switching regulator. The regulator is rated at 500mA max. When using this pin to power other devices or peripherals remember to budget in the current requirement of the Photon 2 first. Unlike the Photon, this pin *CANNOT* be used to power the Photon 2.

EN pin

The **EN** pin is not a power pin, per se, but it controls the 3V3 power. The EN pin is pulled high by a 100K resistor to the higher of VUSB, the micro USB connector, or Li+. Because the pull-up can result in voltages near 5V you should never directly connect EN to a 3.3V GPIO pin. Instead, you should only pull EN low, such as by using an N-channel MOSFET or other open-collector transistor.

The EN pin can force the device into a deep power-down state where it uses very little power. It also can be used to assure that the device is completely reset, similar to unplugging it, with one caveat:

If using the EN pin to deeply reset the device, you must be careful not to allow leakage current back into the MCU by GPIO or by pull-ups to 3V3. If you only power external devices by 3V3 you won't run into this, as 3V3 is de-powered when EN is low.

However, if you have circuitry that is powered by a separate, external power supply, you must be careful. An externally powered circuit that drives a GPIO high when EN is low can provide enough current to keep the MCU from powering down and resetting. Likewise, a pull-up to an external power supply can do the same thing. Be sure that in no circumstances can power be supplied to the MCU when 3V3 is de-powered.

ANTENNA

- The Photon 2 includes an on-module PCB trace antenna and a U.FL connector that allows the user to connect an external antenna.

- The antenna is selected in software. The default is the PCB trace antenna.
- A single antenna is used for both Wi-Fi and BLE.

APPROVED ANTENNAS

In addition to the built-in trace antenna, the following optional external antenna is certified for use with the Photon 2:

Antenna	SKU
Particle P2/Photon2 Wi-Fi Antenna 2.4/5GHz, [x1]	PARANTWM1EA
Particle P2/Photon2 Wi-Fi Antenna 2.4/5GHz, [x50]	PARANTWM1TY

This antenna is used for both Wi-Fi and BLE. In order to use an external antenna, it must be selected in software.

A different dual-band antenna can be used but this will likely require both intentional and unintentional radiator certification.

SWD/JTAG

The Photon 2 module supports programming and debugging use SWD (Serial Wire Debug) using the 10-pin micro JTAG connector on the top of the module.

When the bootloader starts, for a brief period of time a weak pull-up is applied to pin D8 and pull-down to pin D6 to detect whether a SWD debugger is attached. After boot, you can use these pins for regular GPIO, but beware of a possible GPIO state change caused by the pull-up or pull-down when using these pins as output.

Pin	JTAG	MCU Pin	Pull at boot
D7	SWDIO	PA[27]	Pull-up
D6	SWCLK	PB[3]	Pull-down
3V3	Power		
GND	Ground		
RST	Reset		

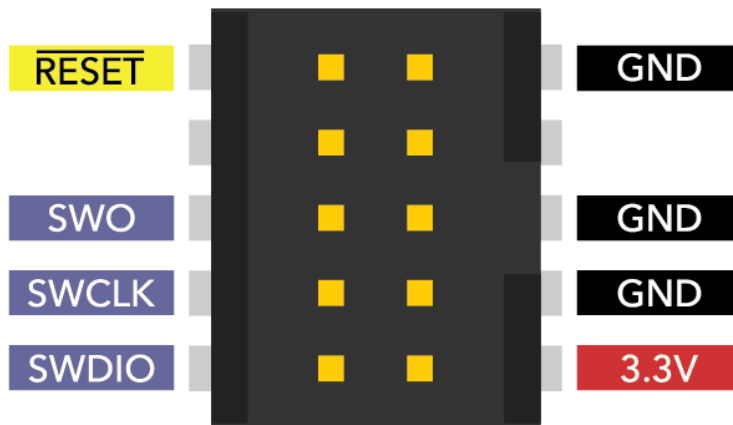

LED STATUS

System RGB LED

For a detailed explanation of different color codes of the RGB system LED, please take a look [here](#).

Charge status LED

State	Description
ON	Charging in progress
OFF	Charging complete

Memory map

FLASH LAYOUT OVERVIEW

Address	File	Purpose
0x00000000	p2-prebootloader-mbr	This file is factory configured and must never be overwritten
0x00004000	p2-bootloader	Device OS bootloader
0x00014000	p2-prebootloader-part1	Bootloader for KM0 processor, infrequently modified
0x00060000	p2-system-part1	Device OS system part

- The location of the user binary is dependent on the size of the user binary and is not flashed to a fixed location.
- **Do not chip erase the RTL872x under any circumstances!** Also do not flash anything to address 0 (prebootloader-mbr). The prebootloader-mbr is factory configured for your specific device with the private keys necessary for secure boot. If you erase or overwrite this portion of the flash you will not be able to program or use the device again.

DCT LAYOUT

The DCT area of flash memory has been mapped to a separate DFU media device so that we can incrementally update the application data. This allows one item (say, server public key) to be updated without erasing the other items.

Region	Offset	Size
system flags	0	32
version	32	2
device private key	34	1216
device public key	1250	384
ip config	1634	120
feature flags	1754	4
country code	1758	4
claim code	1762	63
claimed	1825	1
ssid prefix	1826	26
device code	1852	6
version string	1858	32
dns resolve	1890	128
reserved1	2018	64
server public key	2082	768
padding	2850	2
flash modules	2852	100
product store	2952	24
antenna selection	2976	1
cloud transport	2977	1
alt device public key	2978	128
alt device private key	3106	192
alt server public key	3298	192

alt server address	3490	128
device id	3618	12
radio flags	3630	1
mode button mirror	3631	32
led mirror	3663	96
led theme	3759	64
reserved2	3823	435

Note: Writing 0xFF to offset 34 (DEFAULT) or 3106 (ALTERNATE) will cause the device to regenerate a new private key on the next boot. Alternate keys are currently unsupported on the P1 but are used on the Electron as UDP/ECC keys. You should not need to use this feature unless your keys are corrupted.

```
// Regenerate Default Keys
echo -en "\xFF" > fillbyte && dfu-util -d 2b04:d00a -a 1 -s 34 -D fillbyte
// Regenerate Alternate Keys
echo -en "\xFF" > fillbyte && dfu-util -d 2b04:d00a -a 1 -s 3106 -D
fillbyte
```

Pin and button definition

Peripheral Type	Qty	Input(I) / Output(O)
Digital	20	I/O
Analog (ADC)	6	I
SPI	2	I/O
I2C	1	I/O
UART	3	I/O
USB	1	I/O
PWM	5	O

PIN MARKINGS

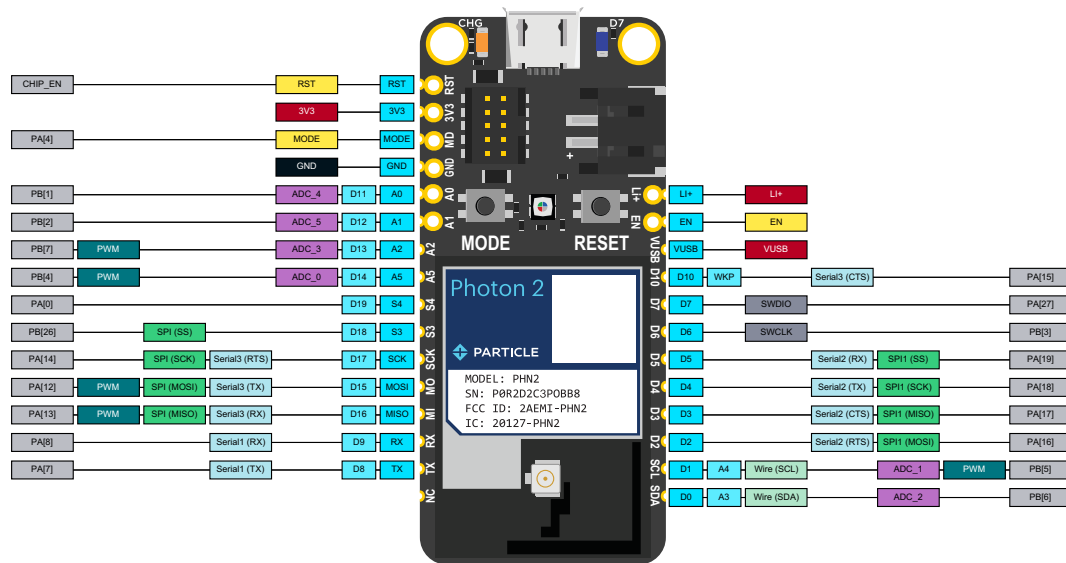

GPIO AND PORT LISTING

Pin Name	MCU
A0 / D11	ADC_4 PB[1]
A1 / D12	ADC_5 PB[2]
A2 / D13	ADC_3 PB[7]
A5 / D14	ADC_0 PB[4]
D0 / A3	ADC_2 Wire (SDA) PB[6]
D1 / A4	ADC_1 Wire (SCL) PB[5]
D10 / WKP	Serial3 (CTS) PA[15]
D2	SPI1 (MOSI) Serial2 (RTS) PA[16]
D3	SPI1 (MISO) Serial2 (CTS) PA[17]
D4	SPI1 (SCK) Serial2 (TX) PA[18]
D5	SPI1 (SS) Serial2 (RX) PA[19]
D6	SWCLK PB[3]
D7	SWDIO PA[27]
MISO / D16	SPI (MISO) Serial3 (RX) PA[13]
MOSI / D15	SPI (MOSI) Serial3 (TX) PA[12]
RX / D9	Serial1 (RX) PA[8]
S3 / D18	SPI (SS) PB[26]

S4 / D19			PA[0]
SCK / D17	SPI (SCK)	Serial3 (RTS)	PA[14]
TX / D8		Serial1 (TX)	PA[7]

ADC (ANALOG TO DIGITAL CONVERTER)

The Photon 2 supports six ADC inputs.

Pin Name	Description	Interface	MCU
A0 / D11	A0 Analog in, GPIO	ADC_4	PB[1]
A1 / D12	A1 Analog in, GPIO	ADC_5	PB[2]
A2 / D13	A2 Analog in, GPIO, PWM.	ADC_3	PB[7]
A5 / D14	A5 Analog in, GPIO, PWM, Was A3 on Gen 3.	ADC_0	PB[4]
D0 / A3	D0 GPIO, I2C SDA, A3 Analog In	ADC_2	PB[6]
D1 / A4	D1 GPIO, PWM, I2C SCL, A4 Analog In	ADC_1	PB[5]

- ADC inputs are single-ended and limited to 0 to 3.3V
- Resolution is 12 bits

The `VBAT_MEAS` pin is connected to Li+ on the Photon 2 and is used to measure the battery voltage by using `analogRead(A6)`. The value returned is 0 - 4095 (inclusive, 12-bit) but represents voltage from 0 - 5 VDC, not 3.3V as is the case with the other ADC inputs.

UART SERIAL

The Photon 2 supports three UART serial interfaces.

Pin Name	Description	Interface	MCU
SCK / D17	SPI SCK, D13 GPIO, S3 GPIO, Serial3 RTS	Serial3 (RTS)	PA[14]
MOSI / D15	D15 GPIO, S0 GPIO, PWM, SPI MOSI, Serial3 TX	Serial3 (TX)	PA[12]
MISO / D16	D16 GPIO, S1 GPIO, PWM, SPI MISO, Serial3 RX.	Serial3 (RX)	PA[13]
RX / D9	Serial1 RX (received data), GPIO	Serial1 (RX)	PA[8]
TX / D8	Serial1 TX (transmitted data), GPIO	Serial1 (TX)	PA[7]
D2	D2 GPIO, Serial2 RTS, SPI1 MOSI	Serial2 (RTS)	PA[16]
D3	D3 GPIO, Serial2 CTS, SPI1 MISO	Serial2 (CTS)	PA[17]
D4	D4 GPIO, Serial2 TX, SPI1 SCK	Serial2 (TX)	PA[18]
D5	D5 GPIO, Serial2 RX, SPI1 SS	Serial2 (RX)	PA[19]
D10 / WKP	D10 GPIO. Serial3 CTS, WKP. Was D8/WKP on Gen 3.	Serial3 (CTS)	PA[15]

- The UART pins are 3.3V and must not be connected directly to a RS-232C port or to a 5V TTL serial port
- Hardware flow control is optional; if not used then the RTS and CTS pins can be used as regular GPIO
- Serial1 uses the RTL872x UART_LOG peripheral
- Serial2 uses the RTL872x HS_UART0 peripheral
- Serial3 uses the RTL872x LP_UART peripheral
- Supported baud rates: 110, 300, 600, 1200, 9600, 14400, 19200, 28800, 38400, 57600, 76800, 115200, 128000, 153600, 230400, 500000, 921600, 1000000, 1382400, 1444400, 1500000, 1843200, 2000000, 2100000, 2764800, 3000000, 3250000, 3692300, 3750000, 4000000, 6000000

SPI

The Photon 2 supports two SPI (serial peripheral interconnect) ports.

Pin Name	Description	Interface	MCU
S3 / D18	S3 GPIO, SPI SS, Was A5 on Gen 3.	SPI (SS)	PB[26]
SCK / D17	SPI SCK, D13 GPIO, S3 GPIO, Serial3 RTS	SPI (SCK)	PA[14]
MOSI / D15	D15 GPIO, S0 GPIO, PWM, SPI MOSI, Serial3 TX	SPI (MOSI)	PA[12]
MISO / D16	D16 GPIO, S1 GPIO, PWM, SPI MISO, Serial3 RX.	SPI (MISO)	PA[13]
D2	D2 GPIO, Serial2 RTS, SPI1 MOSI	SPI1 (MOSI)	PA[16]
D3	D3 GPIO, Serial2 CTS, SPI1 MISO	SPI1 (MISO)	PA[17]
D4	D4 GPIO, Serial2 TX, SPI1 SCK	SPI1 (SCK)	PA[18]
D5	D5 GPIO, Serial2 RX, SPI1 SS	SPI1 (SS)	PA[19]

- The SPI port is 3.3V and must not be connected directly to devices that drive MISO at 5V
- If not using a SPI port, its pins can be used as GPIO
- Any pins can be used as the SPI chip select
- Multiple devices can generally share a single SPI port
- SPI uses the RTL872x SPI1 peripheral (25 MHz maximum speed)
- SPI1 uses the RTL872x SPI0 peripheral (50 MHz maximum speed)

If you are using SPI, Device OS 5.3.1 or later is recommended. Prior to that version, SPI ran at half of the set speed, and SPI1 ran at double the set speed. Timing has also been improved for large DMA transfers; prior to 5.3.1, there could be 1 μ s gaps for every 16 bytes of data transferred.

I2C

The Photon 2 supports one I2C (two-wire serial interface) port.

Pin Name	Description	Interface	MCU
D0 / A3	D0 GPIO, I2C SDA, A3 Analog In	Wire (SDA)	PB[6]
D1 / A4	D1 GPIO, PWM, I2C SCL, A4 Analog In	Wire (SCL)	PB[5]

- The I2C port is 3.3V and must not be connected directly a 5V I2C bus
- Maximum bus speed is 400 kHz
- External pull-up resistors are required for I2C
- If not using I2C, pins D0 and D1 can be used as GPIO

BOOT MODE PINS

These pins have a special function at boot. Beware when using these pins as input as they can trigger special modes in the MCU.

Pin	Pin Name	Description	MCU
15	TX / D8	Low at boot triggers ISP flash download	PA[7]
22	D6	SWCLK. 40K pull-down at boot.	PB[3]
23	D7	SWDIO. 40K pull-up at boot. Low at boot triggers MCU test mode.	PA[27]

BATTERY AND CHARGE PINS

The Photon 2 does not have a fuel gauge chip, however you can determine the voltage of the LiPo

battery, if present.

```
float voltage = analogRead(A6) /  
819.2;
```

The constant is from the ADC range (0 - 4095) mapped to the voltage from 0 - 5 VDC (the maximum supported on VBAT_MEAS).

The charge indicator on the Photon 2 can be read using:

```
pinMode(CHG, INPUT_PULLUP);  
bool charging =  
digitalRead(CHG);
```

On the Photon 2, the `CHG` digital input is `HIGH` (1) when charging and `LOW` (0) when not charging.

BLE (BLUETOOTH LE)

BLE Central Mode on the P2 and Photon 2 is only supported in Device OS 5.1.0 and later. Earlier versions only supported BLE Peripheral Mode.

SLEEP

The Photon 2 can wake from `STOP` or `ULTRA_LOW_POWER` sleep mode on any GPIO, `RISING`, `FALLING`, or `CHANGE`.

The Photon 2 can only wake from `HIBERNATE` sleep mode on pin D10, `RISING`, `FALLING`, or `CHANGE`. Pin D10 is the same module pin location as the Argon pin D8, which is also the WKP pin.

RAM

The P2 has 512 KB of static RAM (SRAM) and 4 MB of pseudo-static RAM (PSRAM).

Around 3072 KB (3 MB) of RAM is available for user applications. Heap allocations are made first from SRAM, then from PSRAM, as necessary.

RETAINED MEMORY

The P2 and Photon 2 have limited support for retained memory in Device OS 5.3.1 and later:

Retained memory is preserved with the following limitations:

- When entering `HIBERNATE` sleep mode.
- Under programmatic reset, such as `System.reset()` and OTA firmware upgrades.
- In limited cases when using pin reset (RESET button or externally triggered reset).

By default, the retained memory is saved every 10 seconds, so changes made to retained variables between the last save and an unplanned system reset will be lost. Calling `System.backupRamSync` on the P2 and Photon 2 can make sure the data is saved. The data is saved to a dedicated flash page in the RTL827x MCU however you should avoid saving the data extremely frequently as it is slower than RAM and will cause flash wear.

Prior to Device OS 5.3.1, retained memory is not supported. The flash file system can be used, or you can use an external chip such as an I2C or SPI FRAM.

PINS PHOTON 2 VS. P2

The pins on the Photon 2 map directly the pins with the same name on the P2.

Photon 2 Pin Name	Photon 2 Description	P2 Pin Name	P2 Description	P2 Pin Number	MCU
A0 / D11	A0 Analog in, GPIO	A0 / D11	A0 Analog in, GPIO	50	PB[1]
A1 / D12	A1 Analog in, GPIO	A1 / D12	A1 Analog in, GPIO	43	PB[2]
A2 / D13	A2 Analog in, GPIO, PWM.	A2 / D13	A2 Analog in, PWM, GPIO	49	PB[7]
A5 / D14	A5 Analog in, GPIO, PWM, Was A3 on Gen 3.	A5 / D14	A5 Analog in, GPIO, PWM.	23	PB[4]
D0 / A3	D0 GPIO, I2C SDA, A3 Analog In	D0 / A3	D0 GPIO, I2C SDA, A3 Analog In	36	PB[6]
D1 / A4	D1 GPIO, PWM, I2C SCL, A4 Analog In	D1 / A4	D1 GPIO, PWM, I2C SCL, A4 Analog In	35	PB[5]
D10 / WKP	D10 GPIO. Serial3 CTS, WKP. Was D8/WKP on Gen 3.	D10 / WKP	D10 GPIO, Serial 3 CTS, WKP. (Was WKP/A7 on P1.)	30	PA[15]
D2	D2 GPIO, Serial2 RTS, SPI1 MOSI	D2	D2 GPIO, Serial2 RTS, SPI1 MOSI	45	PA[16]
D3	D3 GPIO, Serial2 CTS, SPI1 MISO	D3	D3 GPIO, Serial2 CTS, SPI1 MISO	51	PA[17]
D4	D4 GPIO, Serial2 TX, SPI1 SCK	D4	D4 GPIO, Serial2 TX, SPI1 SCK	52	PA[18]
D5	D5 GPIO, Serial2 RX, SPI1 SS	D5	D5 GPIO, Serial2 RX, SPI1 SS	53	PA[19]
D6	D6 GPIO, SWCLK.	D6	D6 GPIO, SWCLK	55	PB[3]
D7	D7 GPIO, Blue LED, SWDIO	D7	D7 GPIO, SWDIO	54	PA[27]
MISO / D16	D16 GPIO, S1 GPIO, PWM, SPI MISO, Serial3 RX.	S1 / D16	S1 GPIO, PWM, SPI MISO, Serial3 RX. (Was P1S1 on P1.)	41	PA[13]
MODE	MODE button, has internal pull-up	MODE	MODE button. Pin number constant is BTN. External pull-up required!	46	PA[4]
MOSI / D15	D15 GPIO, S0 GPIO, PWM, SPI MOSI, Serial3 TX	S0 / D15	S0 GPIO, PWM, SPI MOSI, Serial3 TX. (Was P1S0 on P1.)	40	PA[12]
RST	Hardware reset. Pull low to reset; can leave unconnected in normal operation.	RST	Hardware reset. Pull low to reset; can leave unconnected in normal operation.	34	CHIP_EN
RX / D9	Serial1 RX (received data), GPIO	RX / D9	Serial1 RX (received data), GPIO	63	PA[8]
S3 / D18	S3 GPIO, SPI SS, Was A5 on Gen 3.	S3 / D18	S3 GPIO. (Was P1S3 on P1.), SPI SS	44	PB[26]
S4 / D19	S4 GPIO, Was A4 on Gen 3.	S4 / D19	S4 GPIO. (Was P1S4 on P1.)	47	PA[0]
SCK / D17	SPI SCK, D13 GPIO, S3 GPIO, Serial3 RTS	S2 / D17	S2 GPIO, SPI SCK, Serial3 RTS. (Was P1S2 on P1.)	42	PA[14]
TX / D8	Serial1 TX (transmitted data), GPIO	TX / D8	Serial1 TX (transmitted data), GPIO	64	PA[7]

COMPLETE PIN LISTING

Pin Name	Description	MCU
RST	Hardware reset. Pull low to reset; can leave unconnected in normal operation.	CHIP_EN
3V3	Regulated 3.3V DC output, maximum load 500 mA	
MODE	MODE button, has internal pull-up	PA[4]
GND	Ground.	
A0 / D11	A0 Analog in, GPIO	PB[1]
A1 / D12	A1 Analog in, GPIO	PB[2]
A2 / D13	A2 Analog in, GPIO, PWM.	PB[7]
A5 / D14	A5 Analog in, GPIO, PWM, Was A3 on Gen 3.	PB[4]
S4 / D19	S4 GPIO, Was A4 on Gen 3.	PA[0]
S3 / D18	S3 GPIO, SPI SS, Was A5 on Gen 3.	PB[26]
SCK / D17	SPI SCK, D13 GPIO, S3 GPIO, Serial3 RTS	PA[14]
MOSI / D15	D15 GPIO, S0 GPIO, PWM, SPI MOSI, Serial3 TX	PA[12]
MISO / D16	D16 GPIO, S1 GPIO, PWM, SPI MISO, Serial3 RX.	PA[13]
RX / D9	Serial1 RX (received data), GPIO	PA[8]
TX / D8	Serial1 TX (transmitted data), GPIO	PA[7]
D0 / A3	D0 GPIO, I2C SDA, A3 Analog In	PB[6]
D1 / A4	D1 GPIO, PWM, I2C SCL, A4 Analog In	PB[5]
D2	D2 GPIO, Serial2 RTS, SPI1 MOSI	PA[16]
D3	D3 GPIO, Serial2 CTS, SPI1 MISO	PA[17]
D4	D4 GPIO, Serial2 TX, SPI1 SCK	PA[18]
D5	D5 GPIO, Serial2 RX, SPI1 SS	PA[19]
D6	D6 GPIO, SWCLK.	PB[3]
D7	D7 GPIO, Blue LED, SWDIO	PA[27]
D10 / WKP	D10 GPIO. Serial3 CTS, WKP. Was D8/WKP on Gen 3.	PA[15]
VUSB	Power out (when powered by USB) 5 VDC at 1A maximum. Power in with limitations.	
EN	Power supply enable. Connect to GND to power down. Has internal weak (100K) pull-up.	
LI+	Connected to JST PH LiPo battery connector. 3.7V in or out.	

Technical specification

RECOMMENDED OPERATING CONDITIONS

Parameter	Symbol	Min	Typ	Max	Unit
Operating Temperature	T _{op}	-20		+70	°C
Humidity Range Non condensing, relative humidity				95	%

POWER CONSUMPTION

Parameter	Symbol	Min	Typ	Peak	Unit
Operating Current (uC on, peripherals and radio disabled)	I _{idle}	21.4	23.2	23.8	mA
Operating Current (uC on, BLE advertising)	I _{ble_adv}	54.7	58.7	70.7	mA
Operating Current (uC on, radio connected to access point)	I _{wifi_conn_ap}	54.6	60.5	265	mA
STOP mode sleep, GPIO wake-up	I _{stop_gpio}	492	549	608	uA
STOP mode sleep, time wake-up	I _{stop_intrtc}	500	552	598	uA
ULP mode sleep, GPIO wake-up	I _{ulp_gpio}	492	549	608	uA
ULP mode sleep, time wake-up	I _{ulp_intrtc}	500	552	598	uA
HIBERNATE mode sleep, GPIO wake-up	I _{hib_gpio}		114	249	uA
HIBERNATE mode sleep, time wake-up	I _{hib_intrtc}		114	253	uA

¹The min, and particularly peak, values may consist of very short transients. The typical (typ) values are the best indicator of overall power consumption over time. The peak values indicate the absolute minimum capacity of the power supply necessary, not overall consumption.

Mechanical specifications

{{!--

DIMENSIONS AND WEIGHT

- The Photon 2 is designed to be compliant with the Adafruit Feather form-factor (2.0" x 0.9")
- It has male header pins on the bottom of the module
- Unlike the Argon and Boron, the Photon 2 uses SMD pins on the bottom because the P2 module is too wide to fit between two rows of PTH pins 0.8" apart
- It will not be available in a "no headers" version as there are components on the bottom side of the board
- -}}

MATING CONNECTORS

The Photon 2 uses two single row 0.1" pitch male header pins. One of them is 16 pin while the other is 12 pin. It can be mounted with matching 0.1" pitch female headers with a typical height of 0.335" (8.5mm). When you search for parts like these it can be difficult to navigate the thousands of parts available online so here are a few good choices for the Photon 2 and Argon:

Description	MFG	MFG Part Number
16-pin 0.1" (2.54mm) Female Header	Sullins	PPTC161LFBN-RC
16-pin 0.1" (2.54mm) Female Header	TE	6-535541-4
12-pin 0.1" (2.54mm) Female Header	Sullins	PPTC121LFBN-RC
12-pin 0.1" (2.54mm) Female Header	TE	6-534237-0

RECOMMENDED PCB LAND PATTERN

The Photon 2 can be directly soldered onto the PCB or be mounted with the above mentioned female headers.

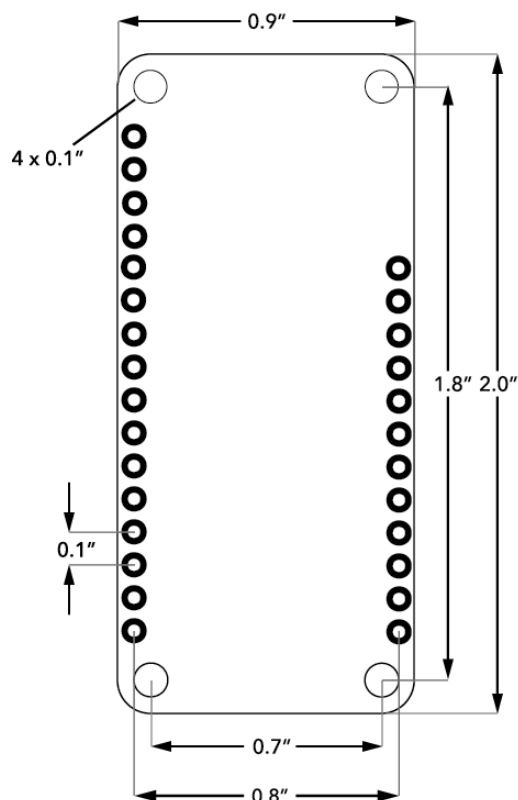

3D MODELS

3D models of the Photon 2 module are available in the [hardware-libraries Github](#) in formats including step, iges, and f3z.

Assembly

WATER SOLUBLE FLUX

If you are attaching a Photon 2 to a custom base board, we recommend using a socket. As there are components on the bottom side of the Photon 2 there is no version available with castellated holes, solder pads, or similar techniques for direct surface mounting.

The pin headers on the bottom of the Photon 2 are not intended to be reflowed using paste-in-hole.

If you wish to surface mount module, you should directly use the P2 module on your base board instead of incorporating the Photon 2.

If you decide to wave solder or hand-solder the Photon 2 directly to your base board, water soluble flux should not be used. There are components within the P2 module that are moisture-sensitive, and wash water can get trapped under the RF shields, causing damage.

Use no-clean flux instead if you must solder the Photon 2 module.

CONFORMAL COATINGS

Photon 2 modules should not use a conformal coating to protect the module from water. Some components on the module cannot be coated and would need to be masked off during coating. This will make the coating process difficult to implement and test.

Furthermore, the buttons cannot be protected by using a coating. Using an enclosure that protects both your base board and the Photon 2 module as a single waterproof assembly is recommended instead.

Ordering information

Photon 2 modules are available from store.particle.io.

SKU	Description	Region	Lifecycle	Replacement
PHN2EDGEKIT	Edge ML Kit for Photon 2 (Photon 2 included)	Global	GA	
PHN2KIT	Photon 2, Kit [x1]	Global	GA	
PHN2MEA	Photon 2 [x1]	Global	Beta	
PHN2MTY	Photon 2, Tray [x50]	Global	Beta	

Qualification and approvals



- RoHS
- CE
- FCC ID: 2AEMI-P2
- IC: 20127-P2

Product handling

MOISTURE SENSITIVITY LEVELS

The Moisture Sensitivity Level (MSL) relates to the packaging and handling precautions required. The P1 module is rated level 3. In general, this precaution applies for Photons without headers. When reflowing a P1 directly onto an application PCB, increased moisture levels prior to reflow can damage sensitive electronics on the P1. A bake process to reduce moisture may be required.

For more information regarding moisture sensitivity levels, labeling, storage and drying see the MSL standard see IPC/JEDEC J-STD-020 (can be downloaded from www.jedec.org).

ESD PRECAUTIONS

The P1 module contains highly sensitive electronic circuitry and is an Electrostatic Sensitive Device (ESD). Handling a P1 module without proper ESD protection may destroy or damage it permanently. Proper ESD handling and packaging procedures must be applied throughout the processing, handling and operation of any application that incorporates P1 modules. ESD precautions should be implemented on the application board where the P1 module is mounted. Failure to observe these precautions can result in severe damage to the P1 module!

Default settings

The P2 module comes pre-programmed with a bootloader and a user application called Tinker. This application works with an iOS and Android app also named Tinker that allows you to very easily toggle digital pins, take analog and digital readings and drive variable PWM outputs.

The bootloader allows you to easily update the user application via several different methods, USB, OTA, Serial Y-Modem, and also internally via the Factory Reset procedure. All of these methods have multiple tools associated with them as well.

You may use the [Particle Web IDE](#) to code, compile and flash a user application OTA (Over The Air). [Particle Workbench](#) is a full-featured desktop IDE for Windows, Mac, and Linux based on VSCode and supports both cloud-based and local gcc-arm compiles. The [Particle CLI](#) provides a command-line interface for cloud-based compiles and flashing code over USB.

Glossary

Radio Frequency

SMT

Surface Mount Technology (often associated with SMD which is a surface mount device).

AP

Access Point

USB

Universal Serial Bus

Quiescent current

Current consumed in the deepest sleep state

FT

Five-tolerant; Refers to a pin being tolerant to 5V.

3V3

+3.3V; The regulated +3.3V supply rail. Also used to note a pin is only 3.3V tolerant.

RTC

Real Time Clock

OTA

Over The Air; describing how firmware is transferred to the device.

FCC IC CE warnings and end product labeling requirements

FEDERAL COMMUNICATION COMMISSION INTERFERENCE STATEMENT

This equipment has been tested and found to comply with the limits for a Class B digital device, pursuant to Part 15 of the FCC Rules. These limits are designed to provide reasonable protection against harmful interference in a residential installation. This equipment generates, uses and can radiate radio frequency energy and, if not installed and used in accordance with the instructions, may cause harmful interference to radio communications. However, there is no guarantee that interference will not occur in a particular installation. If this equipment does cause harmful interference to radio or television reception, which can be determined by turning the equipment off and on, the user is encouraged to try to correct the interference by one of the following measures:

- Reorient or relocate the receiving antenna.
- Increase the separation between the equipment and receiver.
- Connect the equipment into an outlet on a circuit different from that to which the receiver is connected.
- Consult the dealer or an experienced radio/TV technician for help.

FCC Caution: Any changes or modifications not expressly approved by the party responsible for compliance could void the user's authority to operate this equipment. This device complies with Part 15 of the FCC Rules. Operation is subject to the following two conditions:

1. This device may not cause harmful interference, and
2. This device must accept any interference received, including interference that may cause undesired operation.

FCC Radiation Exposure Statement: This equipment complies with FCC radiation exposure limits set forth for an uncontrolled environment. This transmitter module must not be co-located or operating in conjunction with any other antenna or transmitter. This End equipment should be installed and operated with a minimum distance of 20 centimeters between the radiator and your body.

IMPORTANT NOTE: In the event that these conditions can not be met (for example certain laptop configurations or co-location with another transmitter), then the FCC authorization is no longer considered valid and the FCC ID can not be used on the final product. In these circumstances, the OEM integrator will be responsible for re-evaluating the end product (including the transmitter) and obtaining a separate FCC authorization.

End Product Labeling The final end product must be labeled in a visible area with the following:

Contains FCC ID: 2AEMI-P2

Manual Information to the End User The OEM integrator has to be aware not to provide information to the end user regarding how to install or remove this RF module in the user's manual of the end product which integrates this module.

Outdoor Use (US)

To be compliant to FCC §15.407(a) the EIRP is not allowed to exceed 125 mW (21 dBm) at any elevation angle above 30° (measured from the horizon) when operated as an outdoor access point in U-NII-1 band, 5.150-5.250 GHz.

CANADA STATEMENT

This device complies with Industry Canada's licence-exempt RSSs. Operation is subject to the following two conditions:

1. This device may not cause interference; and
2. This device must accept any interference, including interference that may cause undesired operation of the device.

Le présent appareil est conforme aux CNR d'Industrie Canada applicables aux appareils radio exempts de licence.

L'exploitation est autorisée aux deux conditions suivantes:

1. l'appareil ne doit pas produire de brouillage;
2. l'utilisateur de l'appareil doit accepter tout brouillage radioélectrique subi, même si le brouillage est susceptible d'en compromettre le fonctionnement.

Caution Exposure: This device meets the exemption from the routine evaluation limits in section 2.5 of RSS102 and users can obtain Canadian information on RF exposure and compliance. Le dispositif répond à l'exemption des limites d'évaluation de routine dans la section 2.5 de RSS102 et les utilisateurs peuvent obtenir des renseignements canadiens sur l'exposition aux RF et le respect.

The final end product must be labelled in a visible area with the following: The Industry Canada certification label of a module shall be clearly visible at all times when installed in the host device, otherwise the host device must be labelled to display the Industry Canada certification number of the module, preceded by the words "Contains transmitter module", or the word "Contains", or similar wording expressing the same meaning, as follows:

Contains transmitter module IC: 20127-P2

This End equipment should be installed and operated with a minimum distance of 20 centimeters between the radiator and your body. Cet équipement devrait être installé et actionné avec une distance minimum de 20 centimètres entre le radiateur et votre corps.

The end user manual shall include all required regulatory information/warning as shown in this manual.

Restrictions of use

The products are used in terminal products such as industrial control equipment and smart home equipment.

Outdoor use (CA)

- Operation in the band 5150–5250 MHz is only for indoor use to reduce the potential for harmful interference to co-channel mobile satellite systems;
- Operation in the 5600-5650 MHz band is not allowed in Canada. High-power radars are allocated as primary users (i.e., priority users) of the bands 5250-5350 MHz and 5650-5850 MHz and that these radars could cause interference and/or damage to LE-LAN devices.

- Le dispositif de fonctionnement dans la bande 5150-5250 MHz est réservé à une utilisation en intérieur pour réduire le risque d'interférences nuisibles à la co-canal systèmes mobiles par satellite
- Opération dans la bande 5600-5650 MHz n'est pas autorisée au Canada. Haute puissance radars sont désignés comme utilisateurs principaux (c.-à-utilisateurs prioritaires) des bandes 5250-5350 MHz et 5650-5850 MHz et que ces radars pourraient causer des interférences et / ou des dommages à dispositifs LAN-EL.

Transmitter specifications

Frequency Range	RF power rating/field strength	Antenna information	Emissions designator
2412-2462 MHz	0.376704W	PCB Antenna, 2.41 dBi	17M9D1D
2402-2480 MHz	0.009354W	PCB Antenna, 2.41 dBi	1M02F1D
2402-2480 MHz	0.008670W	PCB Antenna, 2.41 dBi	2M06F1D
5180-5240/5190-5230 MHz	0.073282/0.081283W	PCB Antenna, 1.28 dBi	18M6D1D/38M2D1D
5260-5320/5270-5310 MHz	0.081658/0.077090W	PCB Antenna, 1.60 dBi	18M9D1D/37M5D1D
5500-5700/5510-5670 MHz	0.097949/0.091833W	PCB Antenna, 1.74 dBi	19M2D1D/38M0D1D
5745-5825/5755-5795 MHz	0.091411/0.090365W	PCB Antenna, 1.21 dBi	19M6D1D/36M8D1D

OUTDOOR USE (WORLD)

This device is restricted to indoor use when operating in the 5150 to 5350 MHz frequency range. This restriction applies in: AT, BE, BG, CH, CY, CZ, DE, DK, EE, EL, ES, FI, FR, HR, HU, IE, IS, IT, LI, LT, LU, LV, MT, NL, NO, PL, PT, RO, SE, SI, SK, TR, UA, UK(NI).

Revision history

Revision	Date	Author	Comments
pre	2022-03-02	RK	Pre-release initial version
	2022-03-14	RK	Minor edits; no functional changes
	2022-04-08	RK	Added table comparing Photon 2 and P2 pins
	2022-04-12	RK	Added serial baud rates
	2022-04-16	RK	Major changes to pinmap to align with P2
	2022-05-04	RK	USB connector is micro B, not USB C
	2022-08-12	RK	Added listing of pins used at boot
	2022-08-12	RK	Warning about BLE central mode not available
	2022-09-04	RK	BLE central mode available, added power consumption
	2022-10-05	RK	Added power consumption
	2022-11-08	RK	Added external antenna
	2022-11-17	RK	Pin D0 does not have PWM
	2023-01-31	RK	Add Device OS versions
	2023-02-14	RK	Updated Photon 2 graphic to fix pin labels
	2023-03-06	RK	SWDIO is D7 not D8
	2023-03-08	RK	Main CPU (KM4) is M33, not M23
	2023-03-24	RK	Added FCC and IC IDs
	2023-04-03	RK	Fixed typo in FCC ID in one location, IC restrictions
	2023-04-05	RK	Added Device OS 5.3.1 information for SPI and retained memory
	2023-04-10	RK	Outdoor use restrictions
	2023-04-24	RK	Document VBAT_MEAS and CHG
	2023-04-28	RK	Add conformal coating and flux notes
	2023-05-05	RK	Update available RAM
	2023-05-08	RK	Added VBAT_MEAS and CHG to block diagram
	2023-05-18	RK	Add warning that the Photon 2 cannot be powered by 3V3
1	2023-06-20	RK	Initial version
2	2023-06-30	RK	Updated power consumption
3	2023-07-26	RK	EN pin description listed wrong MCU

Known errata

Contact

Web

<https://www.particle.io>

Community Forums

<https://community.particle.io>