

## XHP™3 module with Emitter Controlled 4 diode

### Features

- Electrical features
  - $V_R = 4500\text{ V}$
  - $I_F = 450\text{ A}$ ,  $I_{FRM} = 900\text{ A}$
  - High dynamic robustness
- Mechanical features
  - Package with CTI > 600
  - AlSiC base plate for increased thermal cycling capability
  - High creepage and clearance distances
  - Housing material compliant with the classification R23 (HL3) of the EN45545-2 “Fire protection of railway vehicles”
  - Package with enhanced insulation of 10.4 kV AC 60 s



### Potential applications

- Traction drives
- Medium-voltage converters

### Product validation

- Qualified for industrial applications according to the relevant tests of IEC 60747, 60749 and 60068

### Description

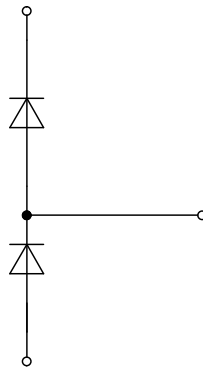

## Table of contents

	<b>Description</b> .....	1
	<b>Features</b> .....	1
	<b>Potential applications</b> .....	1
	<b>Product validation</b> .....	1
	<b>Table of contents</b> .....	2
<b>1</b>	<b>Package</b> .....	3
<b>2</b>	<b>Diode, Inverter</b> .....	3
<b>3</b>	<b>Characteristics diagrams</b> .....	5
<b>4</b>	<b>Circuit diagram</b> .....	7
<b>5</b>	<b>Package outlines</b> .....	8
<b>6</b>	<b>Module label code</b> .....	9
	<b>Revision history</b> .....	10
	<b>Disclaimer</b> .....	11

## 1 Package

**Table 1** Insulation coordination

Parameter	Symbol	Note or test condition	Values	Unit
Isolation test voltage	$V_{ISOL}$	RMS, $f = 50$ Hz, $t = 1$ min	10.4	kV
Partial discharge extinction voltage	$V_{isol}$	RMS, $f = 50$ Hz, $Q_{PD}$ typ. 10 pC	5.1	kV
DC stability	$V_{CE(D)}$	$T_{vj} = 25$ °C, 100 Fit	2900	V
Material of module baseplate			AlSiC	
Creepage distance	$d_{Creep}$	terminal to heatsink	53.0	mm
Creepage distance	$d_{Creep}$	terminal to terminal	53.0	mm
Clearance	$d_{Clear}$	terminal to heatsink	36.0	mm
Clearance	$d_{Clear}$	terminal to terminal	26.0	mm
Comparative tracking index	$CTI$		> 600	

**Table 2** Characteristic values

Parameter	Symbol	Note or test condition	Values			Unit
			Min.	Typ.	Max.	
Stray inductance module	$L_{sCE}$			25		nH
Module lead resistance, terminals - chip	$R_{AA'+CC'}$	$T_C = 25$ °C, per switch		0.33		mΩ
Storage temperature	$T_{stg}$		-40		150	°C
Mounting torque for module mounting	$M$	- Mounting according to valid application note	M6, Screw	4.25	5.75	Nm
Terminal connection torque	$M$	- Mounting according to valid application note	M3, Screw	0.9	1.1	Nm
			M8, Screw	8	10	
Weight	$G$			700		g

## 2 Diode, Inverter

**Table 3** Maximum rated values

Parameter	Symbol	Note or test condition	Values	Unit	
Repetitive peak reverse voltage	$V_{RRM}$		$T_{vj} = -40$ °C	4500	V
			$T_{vj} = 150$ °C	4500	
Continuous DC forward current	$I_F$		450	A	
Repetitive peak forward current	$I_{FRM}$	$t_p = 1$ ms	900	A	

(table continues...)

**Table 3 (continued) Maximum rated values**

Parameter	Symbol	Note or test condition	Values	Unit	
I <sup>2</sup> t - value	I <sup>2</sup> t	t <sub>p</sub> = 10 ms, V <sub>R</sub> = 0 V	T <sub>vj</sub> = 125 °C	87.4	kA <sup>2</sup> s
			T <sub>vj</sub> = 150 °C	79.9	
Maximum power dissipation	P <sub>RQM</sub>		T <sub>vj</sub> = 150 °C	1500	kW
Minimum turn-on time	t <sub>onmin</sub>			10	μs

**Table 4 Characteristic values**

Parameter	Symbol	Note or test condition	Values			Unit	
			Min.	Typ.	Max.		
Forward voltage	V <sub>F</sub>	I <sub>F</sub> = 450 A, V <sub>GE</sub> = 0 V	T <sub>vj</sub> = 25 °C		2.60	3.05	V
			T <sub>vj</sub> = 125 °C		2.50	2.95	
			T <sub>vj</sub> = 150 °C		2.45	2.90	
Peak reverse recovery current	I <sub>RM</sub>	V <sub>CC</sub> = 2800 V, I <sub>F</sub> = 450 A, V <sub>GE</sub> = -15 V, -di <sub>F</sub> /dt = 4900 A/μs (T <sub>vj</sub> = 150 °C)	T <sub>vj</sub> = 25 °C		925		A
			T <sub>vj</sub> = 125 °C		920		
			T <sub>vj</sub> = 150 °C		920		
Recovered charge	Q <sub>r</sub>	V <sub>CC</sub> = 2800 V, I <sub>F</sub> = 450 A, V <sub>GE</sub> = -15 V, -di <sub>F</sub> /dt = 4900 A/μs (T <sub>vj</sub> = 150 °C)	T <sub>vj</sub> = 25 °C		405		μC
			T <sub>vj</sub> = 125 °C		780		
			T <sub>vj</sub> = 150 °C		900		
Reverse recovery energy	E <sub>rec</sub>	V <sub>CC</sub> = 2800 V, I <sub>F</sub> = 450 A, V <sub>GE</sub> = -15 V, -di <sub>F</sub> /dt = 4900 A/μs (T <sub>vj</sub> = 150 °C)	T <sub>vj</sub> = 25 °C		690		mJ
			T <sub>vj</sub> = 125 °C		1400		
			T <sub>vj</sub> = 150 °C		1650		
Thermal resistance, junction to case	R <sub>thJC</sub>	per diode			44.9	K/kW	
Thermal resistance, case to heat sink	R <sub>thCH</sub>	per diode, λ <sub>grease</sub> = 1 W/(m·K)			19.8	K/kW	
Temperature under switching conditions	T <sub>vj op</sub>		-40		150	°C	

Note: Dynamic data valid in conjunction with FF450R45T3E4\_B5 module

### 3 Characteristics diagrams

**Forward characteristic (typical), Diode, Inverter**

$I_F = f(V_F)$

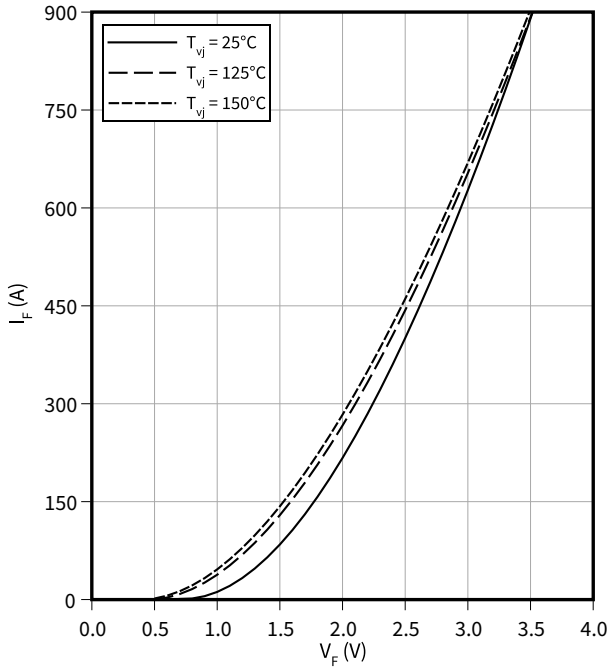

**Switching losses (typical), Diode, Inverter**

$E_{rec} = f(I_F)$

$R_{Gon} = 0.39 \Omega, V_{CE} = 2800 \text{ V}$

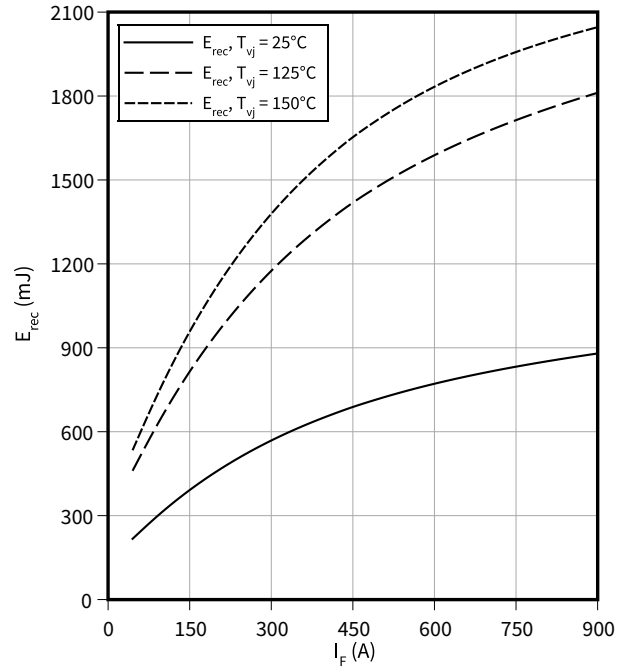

**Switching losses (typical), Diode, Inverter**

$E_{rec} = f(R_G)$

$V_{CE} = 2800 \text{ V}, I_F = 450 \text{ A}$

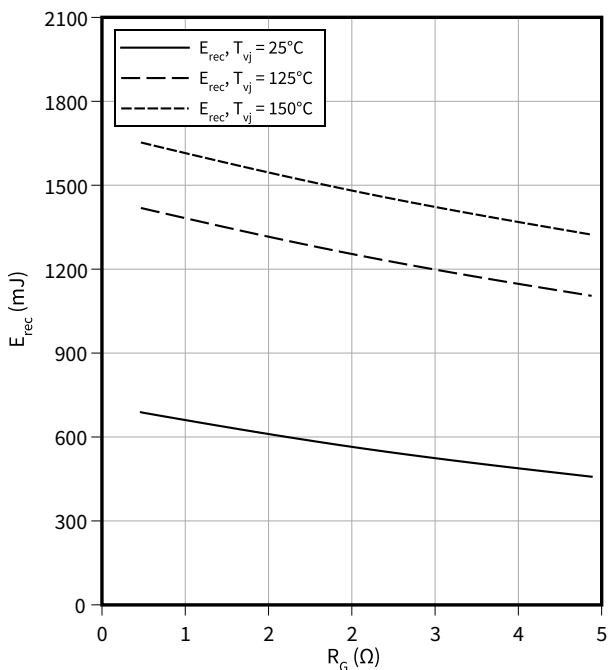

**Safe operating area (SOA), Diode, Inverter**

$I_R = f(V_R)$

$T_{vj} = 150^\circ\text{C}$

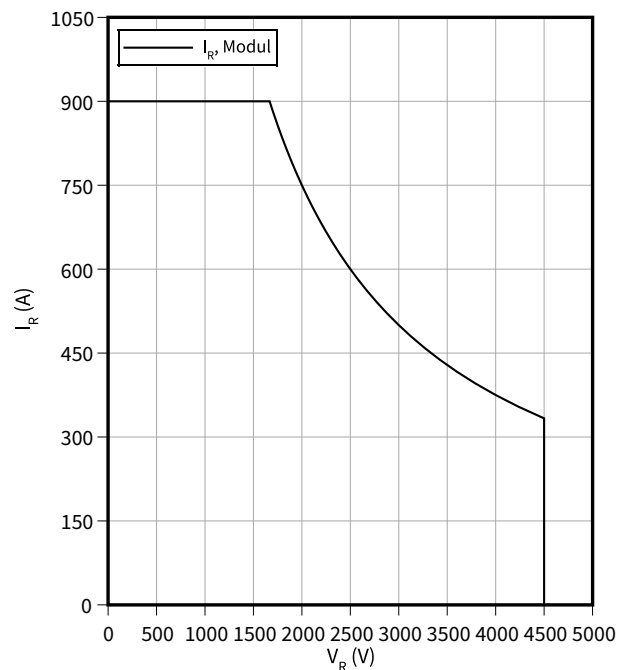

**Transient thermal impedance, Diode, Inverter**

$Z_{th} = f(t)$

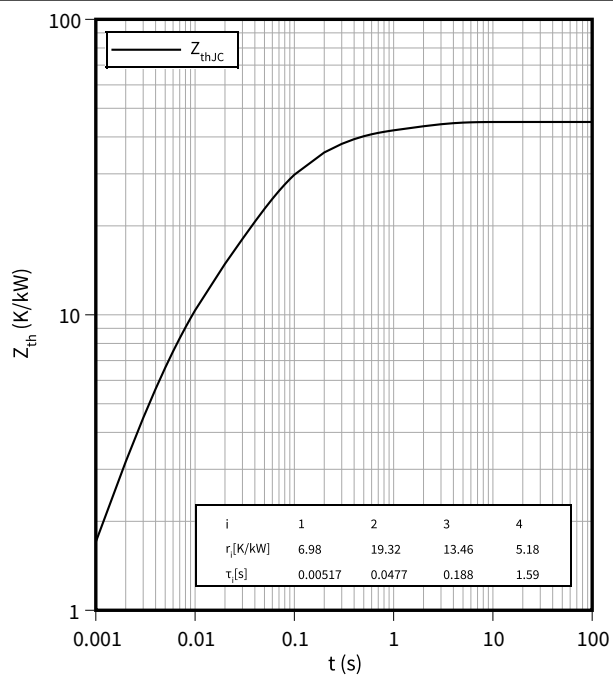

## 4 Circuit diagram

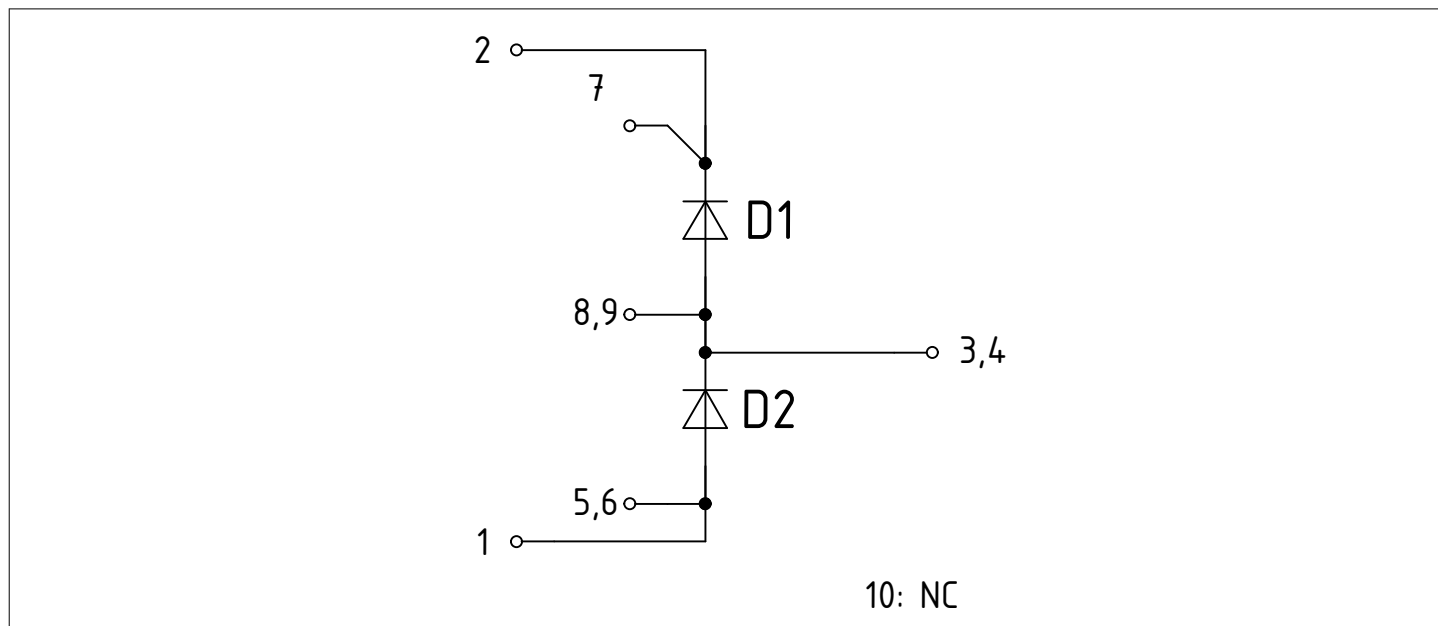

Figure 1

## 5 Package outlines

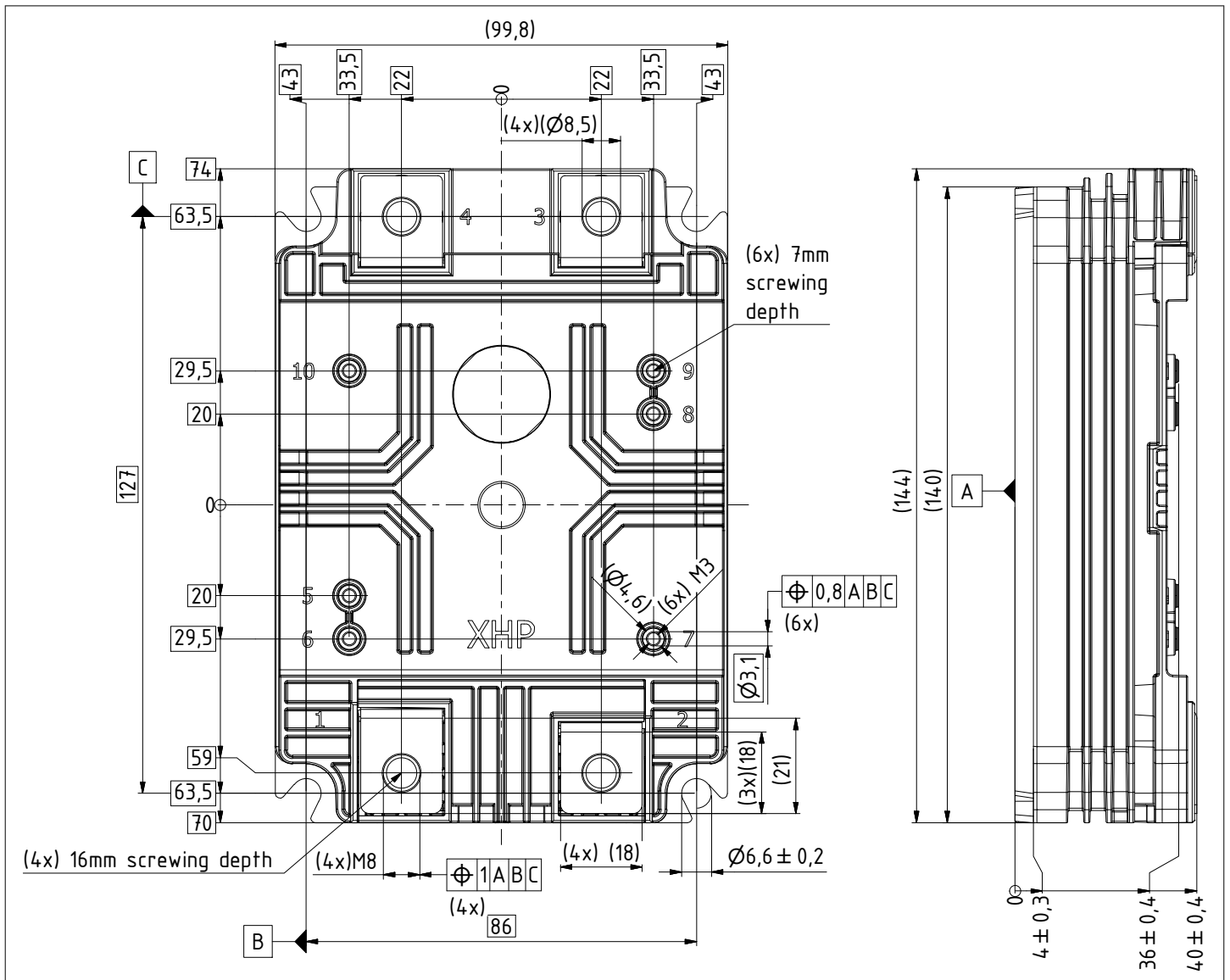

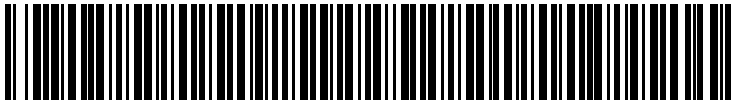

Figure 2



## 6 Module label code

Module label code			
Code format	Data Matrix	Barcode Code128	
Encoding	ASCII text	Code Set A	
Symbol size	16x16	23 digits	
Standard	IEC24720 and IEC16022	IEC8859-1	
Code content	Content	Digit	Example
	Module serial number	1 - 5	71549
	Module material number	6 - 11	142846
	Production order number	12 - 19	55054991
	Date code (production year)	20 - 21	15
	Date code (production week)	22 - 23	30
Example			
	71549142846550549911530		71549142846550549911530

**Figure 3**

## Revision history

Document revision	Date of release	Description of changes
1.00	2023-06-15	Initial version

## Trademarks

All referenced product or service names and trademarks are the property of their respective owners.

**Edition 2023-06-15**

**Published by**

**Infineon Technologies AG**

**81726 Munich, Germany**

**© 2023 Infineon Technologies AG**

**All Rights Reserved.**

**Do you have a question about any aspect of this document?**

**Email: [erratum@infineon.com](mailto:erratum@infineon.com)**

**Document reference**

**IFX-ABF407-001**

## Important notice

The information given in this document shall in no event be regarded as a guarantee of conditions or characteristics ("Beschaffheitsgarantie").

With respect to any examples, hints or any typical values stated herein and/or any information regarding the application of the product, Infineon Technologies hereby disclaims any and all warranties and liabilities of any kind, including without limitation warranties of non-infringement of intellectual property rights of any third party.

In addition, any information given in this document is subject to customer's compliance with its obligations stated in this document and any applicable legal requirements, norms and standards concerning customer's products and any use of the product of Infineon Technologies in customer's applications.

The data contained in this document is exclusively intended for technically trained staff. It is the responsibility of customer's technical departments to evaluate the suitability of the product for the intended application and the completeness of the product information given in this document with respect to such application.

Please note that this product is not qualified according to the AEC Q100 or AEC Q101 documents of the Automotive Electronics Council.

## Warnings

Due to technical requirements products may contain dangerous substances. For information on the types in question please contact your nearest Infineon Technologies office.

Except as otherwise explicitly approved by Infineon Technologies in a written document signed by authorized representatives of Infineon Technologies, Infineon Technologies' products may not be used in any applications where a failure of the product or any consequences of the use thereof can reasonably be expected to result in personal injury.