



# TAOGLAS®



# Datasheet

**Part No:**  
AFXP.125.07.0095A

## Description

Active Flexible Multi-Band GNSS Antenna, covering L1/L5

## Features:

Single Stage LNA

Covers Bands

- GPS L1 & L5
- BeiDou B1
- Galileo E1 & E5a
- GLONASS G1
- IRNSS L5

Dimensions: 76.9 x 47.4 x 2.3mm

Cable: 95mm 1.13mm Coax

Connector: I-PEX MHF® I (U.FL Compatible)

RoHS & Reach Compliant

<b>1.</b>	<b>Introduction</b>	<b>2</b>
<b>2.</b>	<b>Specification</b>	<b>3</b>
<b>3.</b>	<b>Antenna Characteristics</b>	<b>5</b>
<b>4.</b>	<b>Radiation Patterns</b>	<b>9</b>
<b>5.</b>	<b>Active Circuitry Performance</b>	<b>14</b>
<b>6.</b>	<b>Mechanical Drawing</b>	<b>19</b>
<b>7.</b>	<b>Packaging</b>	<b>20</b>
<hr/>		
	Changelog	21

Taoglas makes no warranties based on the accuracy or completeness of the contents of this document and reserves the right to make changes to specifications and product descriptions at any time without notice. Taoglas reserves all rights to this document and the information contained herein. Reproduction, use or disclosure to third parties without express permission is strictly prohibited.



# 1. Introduction



The patent pending AFXP125 embedded flexible antenna is a next generation, active multi-band GNSS antenna designed to cover working constellations in the GNSS L1/L5 spectrum. The AFXP125 comes with active circuitry, so it is a plug and play alternative to customer's design a complex active circuit themselves. The AFXP.125 multi band GNSS antenna is a compact high precision solution for navigation or asset tracking devices where board space is at a premium and cost is a major factor.

The AFXP125 is a linear polarized antenna, however it has an omnidirectional radiation pattern making it less sensitive to device orientation allowing it to be installed in areas where a patch antenna won't work. It comes with a low noise figure to preserve signal quality which helps minimize time to first fix, allowing the device to pick up a location as soon as possible. It also features excellent out-of-band rejection to prevent out-of-band signals from overdriving or damaging its LNAs.

This antenna is made of durable, flexible, polymer with a cable and connector for easy installation. It is designed to be mounted directly to the inner shell of a plastic housing or glass enclosure/cover. No space is needed on the PCBs of your device, but at least 20mm of minimum clearance is required from the ground-plane to achieve optimal antenna efficiency. At 76mm\*47mm\*0.15mm, the antenna is ultrathin and can be applied by a simple peel and stick process, attaching securely to non-metal surfaces via 3M adhesive. It has been tuned to work directly on ABS/PC plastic housings.

The antenna comes with its filter and LNA design making an ideal multi band GNSS antenna solution for compact high precision automotive navigation or asset tracking devices where board space is at a premium.

## Typical Applications

- Telematics & E-Mobility
- Fleet Management & Asset Tracking
- Navigation & handheld devices

Cable type, length and connectors are fully customizable. Please contact your regional Taoglas customer support for further information.

## 2. Specification

GNSS Frequency Bands					
GPS	L1 1575.42 MHz	L2 1227.6 MHz	L5 1176.45 MHz		
	■	□	■		
GLONASS	G1 1602 MHz	G2 1248 MHz	G3 1207 MHz		
	■	□	□		
Galileo	E1 1575.24 MHz	E5a 1176.45 MHz	E5b 1201.5 MHz	E6 1278.75 MHz	
	■	■	□	□	
BeiDou	B1C 1575.42 MHz	B1I 1561 MHz	B2a 1176.45 MHz	B2b 1207.14 MHz	B3 1268.52 MHz
	■	□	■	□	□
L-Band	L-Band 1542 MHz				
	□				
QZSS (Regional)	L1 1575.42 MHz	L2C 1227.6 MHz	L5 1176.45 MHz	L6 1278.75e6	
	■	□	■	□	
IRNSS (Regional)	L5 1176.45 MHz				
	■				
SBAS	L1/E1/B1 1575.42 MHz	L5/B2a/E5a 1176.45 MHz	G1 1602 MHz	G2 1248 MHz	G3 1207 MHz
	■	■	■	□	□

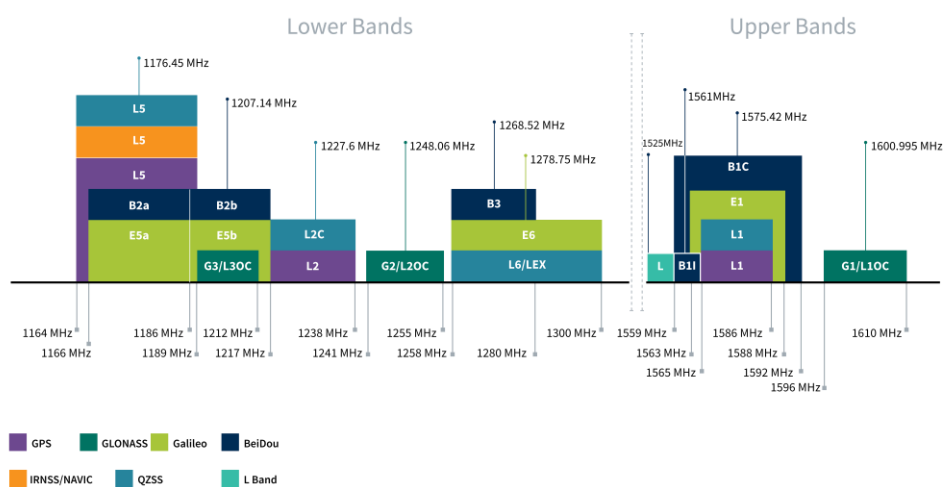

GNSS Bands and Constellations

GNSS Electrical				
Frequency (MHz)	1176.45	1561	1575.42	1603
VSWR (max.)	1:1	1:1	1:1	1:1
Passive Antenna Efficiency (%)	75.31	78.07	77.77	83.63
Passive Antenna Gain at Zenith (dBic)	-3.73	-0.71	-0.63	-0.13
Group Delay Mean (ns)	3.31	0.44	0.74	2.24
Group Delay Variation (ns)	-1.33	-0.74	-2.33	-1.4
P1dB (dBm)	-12	-7.2	-7.2	-7.2
Polarization		Linear		
Impedance		50 Ω		

LNA and Filter Electrical Properties				
Frequency (MHz)	1176.45	1561	1575.42	1603
Gain@5V (dBic)	14.59	13.32	13.07	12.75
Noise@5V (dBic)	2.62	2.55	2.54	2.87
Current Consumption @5V	10mA			

Total Specification (Through Antenna, SAW Filter and LNA)				
Frequency (MHz)	1176.45	1561	1575.42	1603
Active Antenna Peak Gain (dBi)	22.0	18.0	17.5	17.5
Output Impedance		50 Ω		

Mechanical	
Dimensions	76.9 x 47.4 x 2.3mm
Material	PCB
Weight-40	3g
Connector	IPEX I (U.FL COMPATIBLE)
Cable	1.13 MICRO COAX (BLACK) 95mm

Environmental	
Operation Temperature	-40°C - +85°C
Storage Temperature	-40°C - +85°C

### 3. Antenna Characteristics

#### 3.1 Test Setup

AUT



Vector Network Analyzer

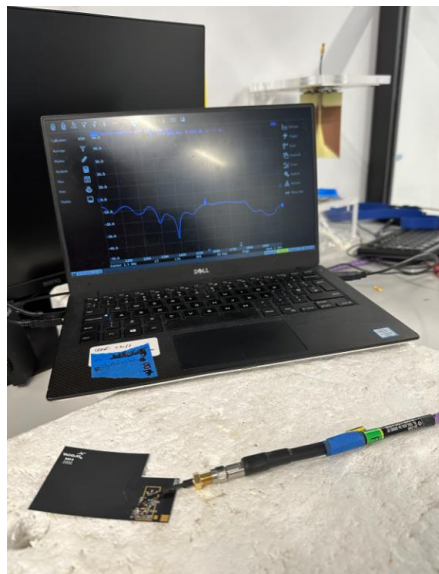

### 3.2 Return Loss

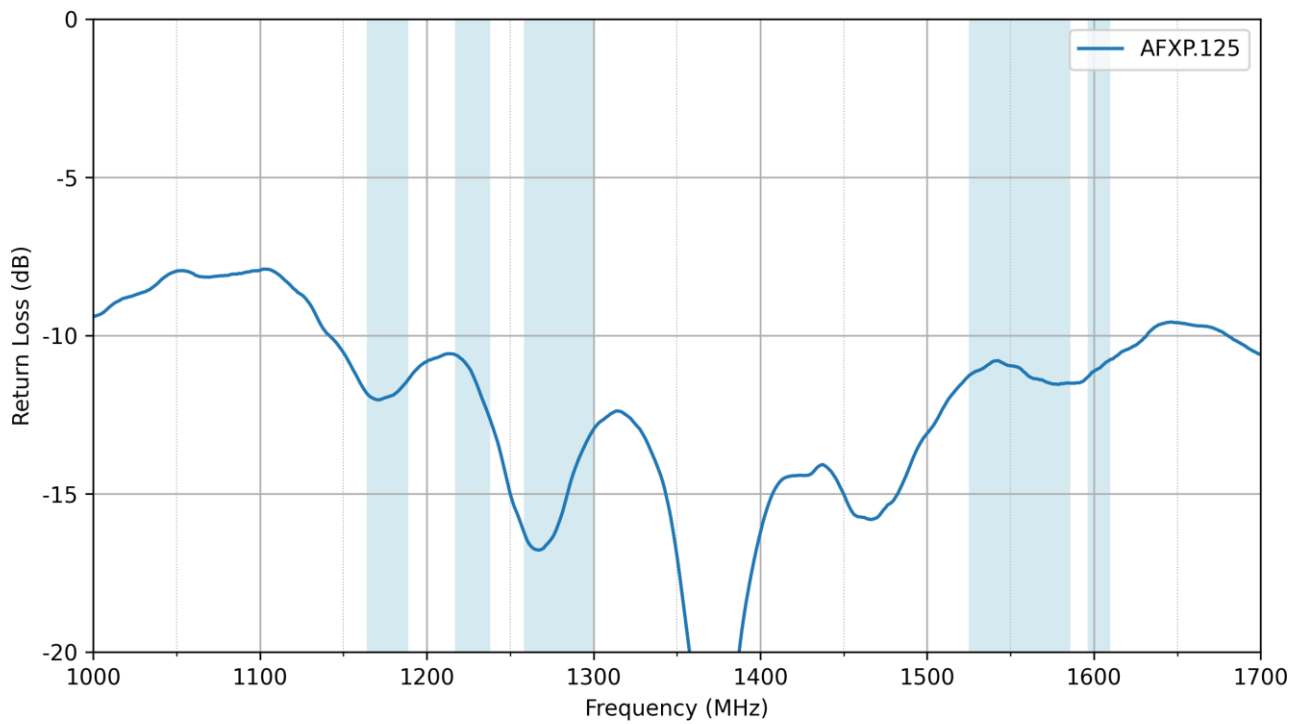

### 3.3 VSWR

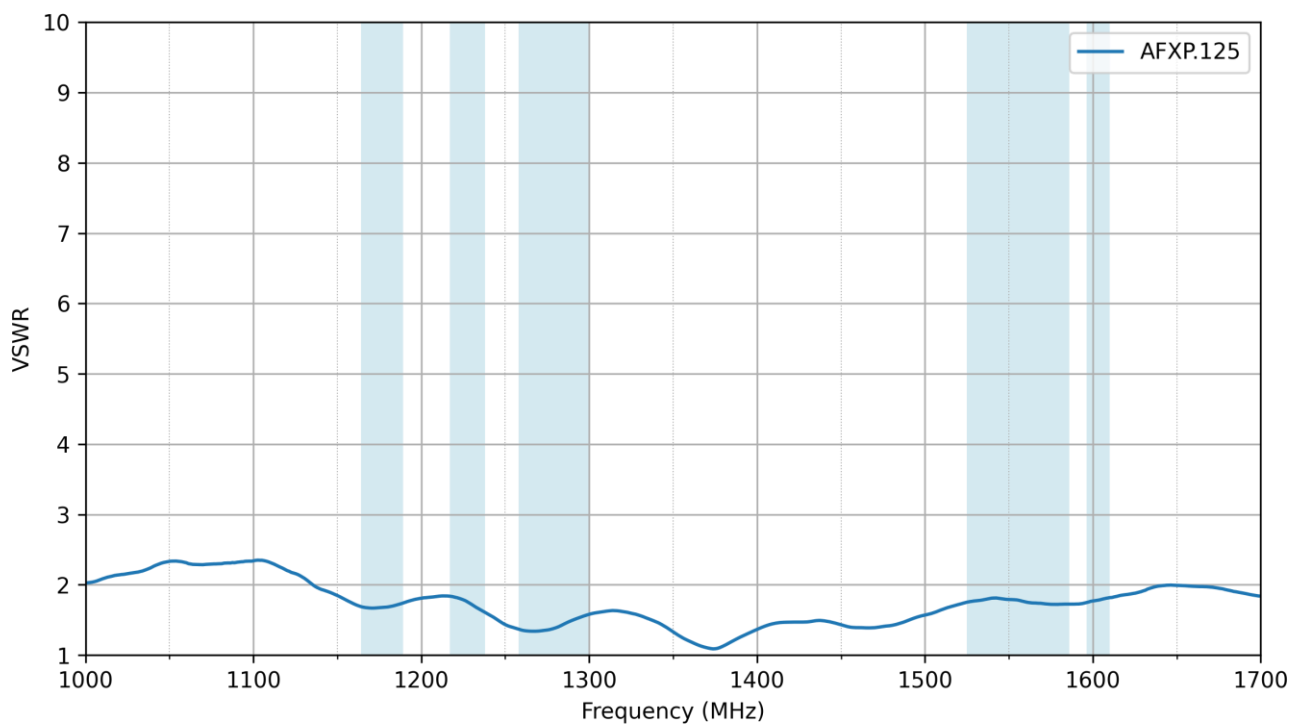

### 3.4 Efficiency

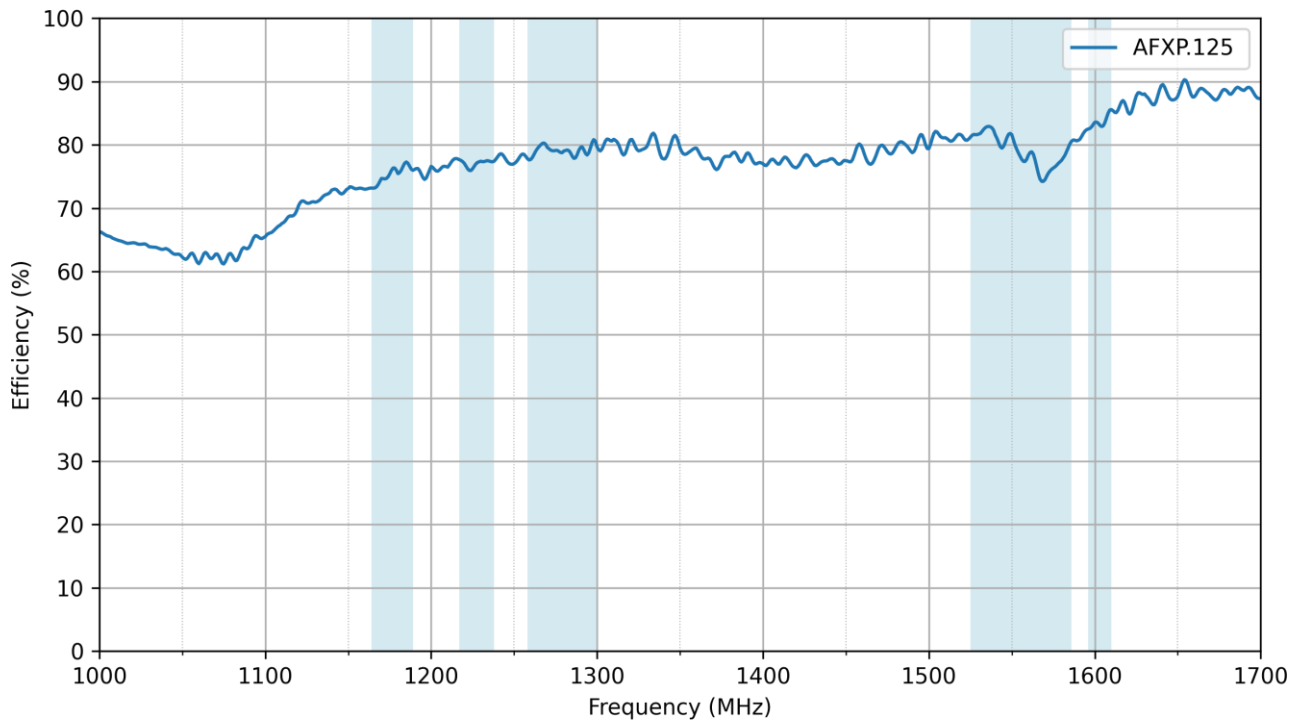

### 3.5 Average Gain

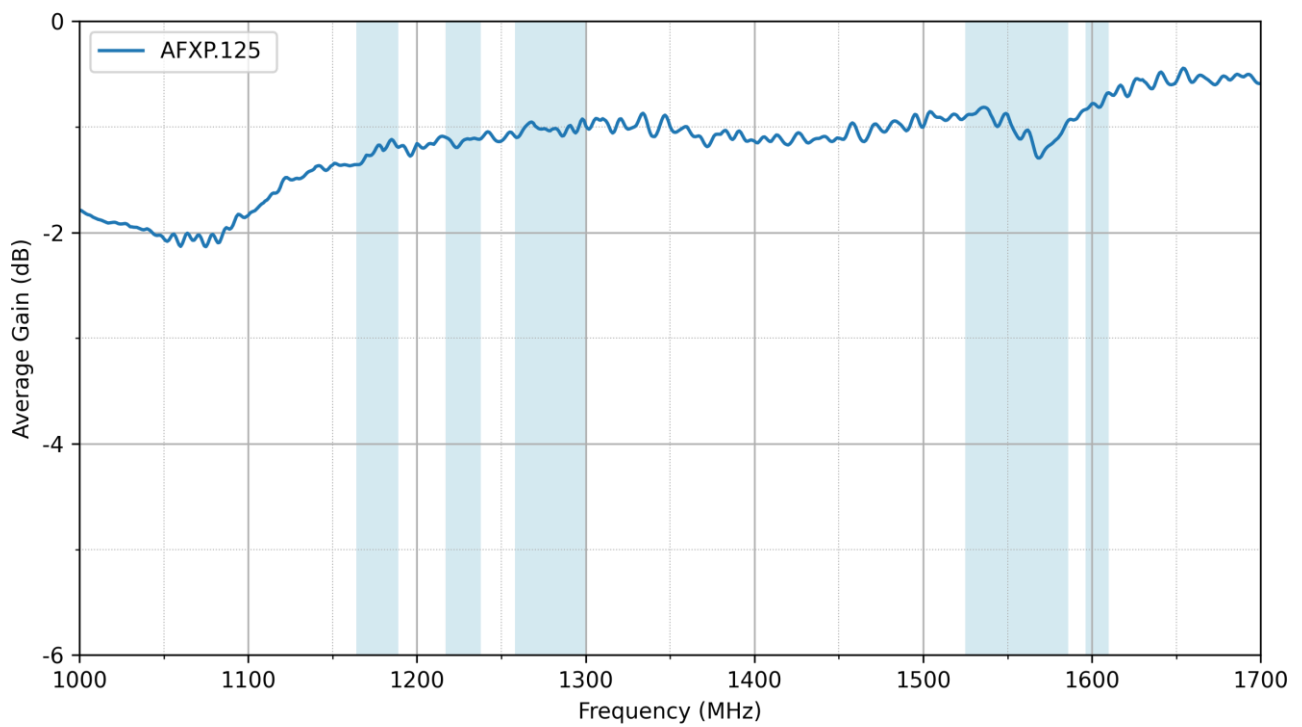



3.6 Peak Gain

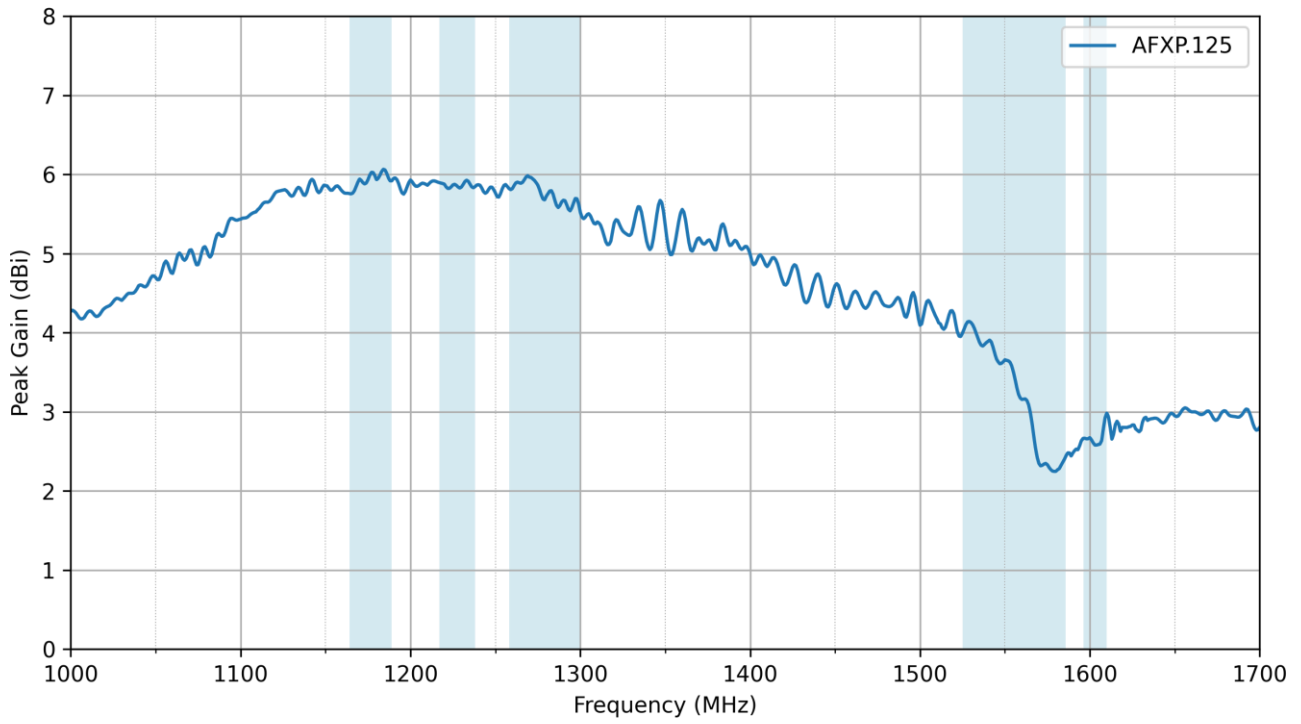

## 4. Radiation Patterns

### 4.1 Test Setup

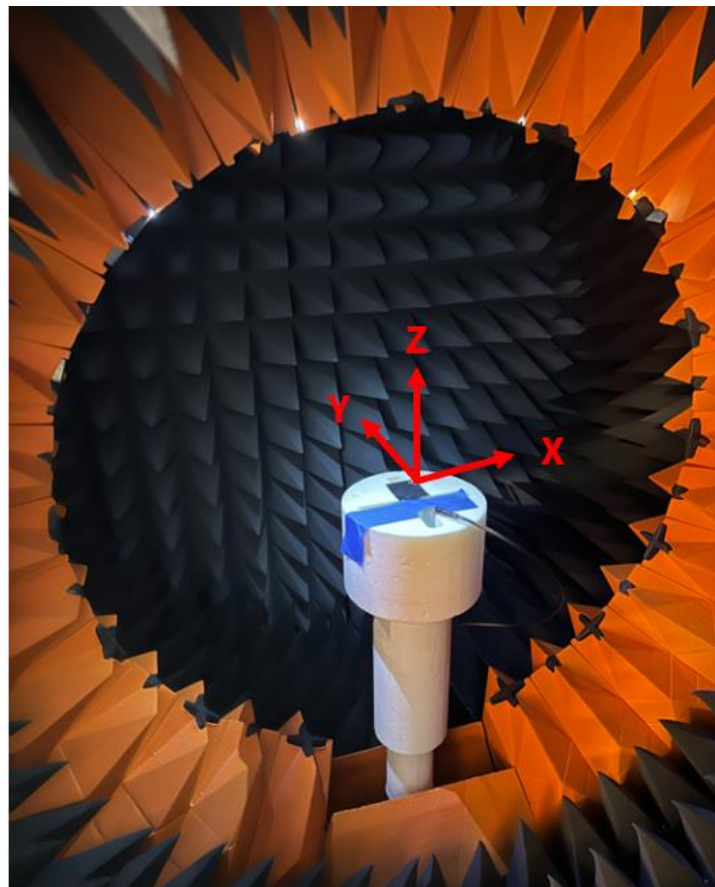
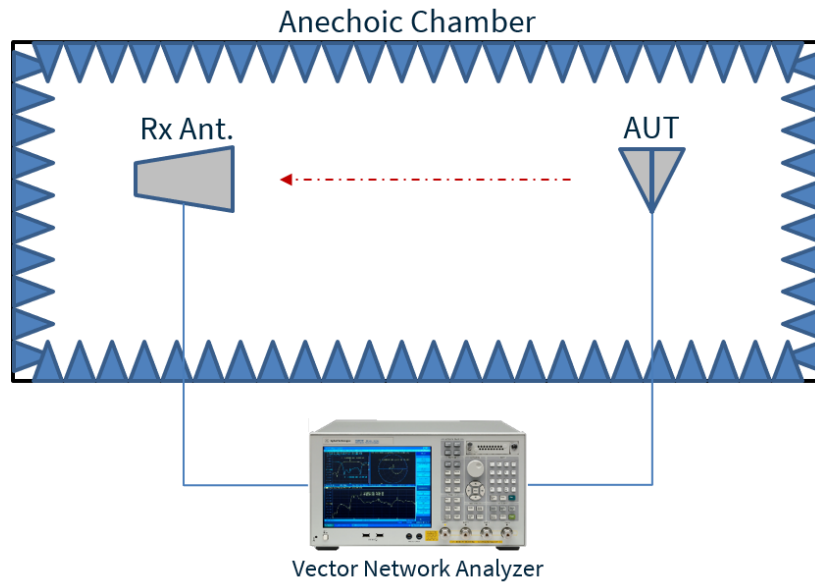

4.2 Patterns at 1176 MHz

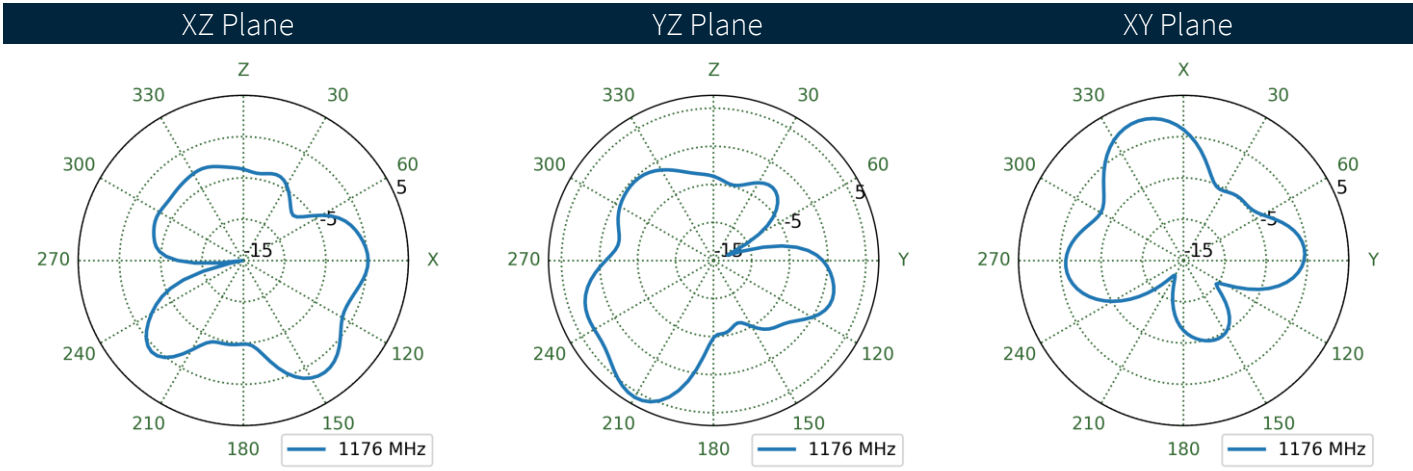
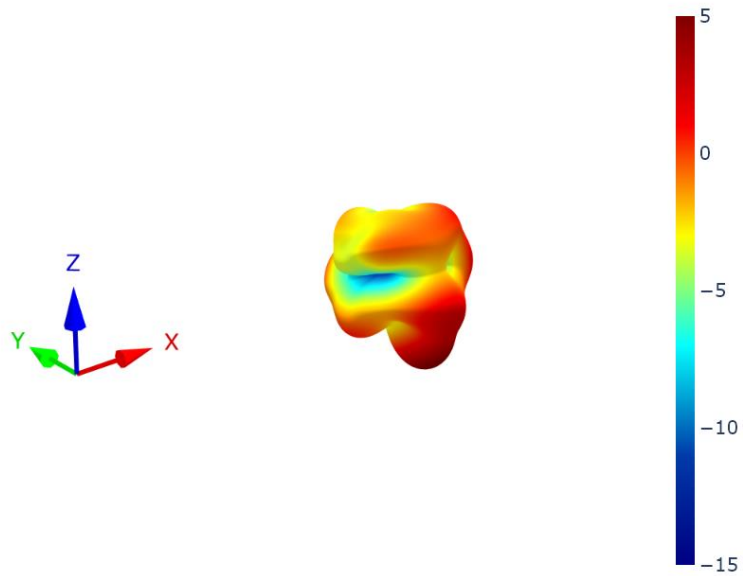

4.3 Patterns at 1562 MHz

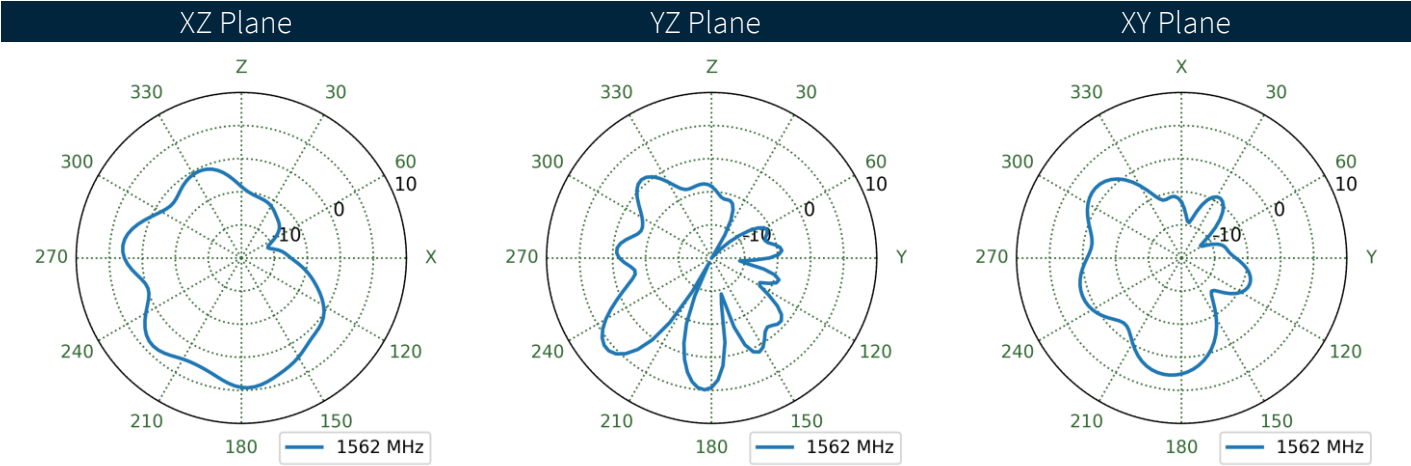
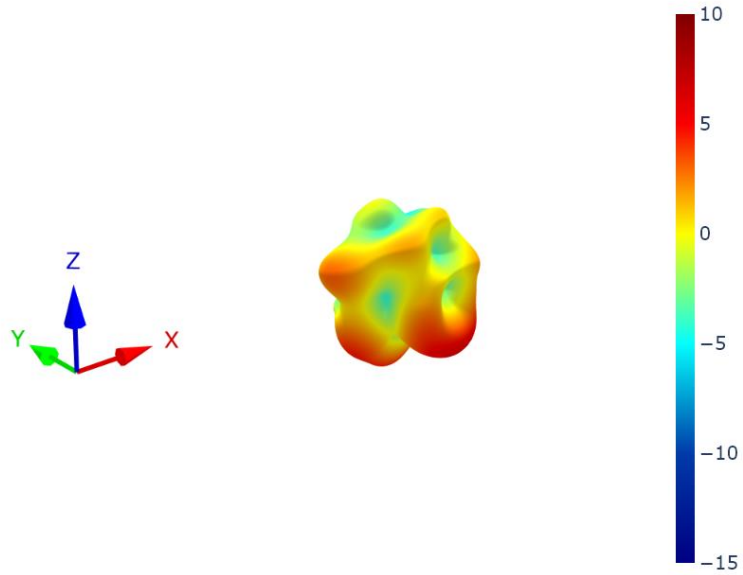

4.4 Patterns at 1575 MHz

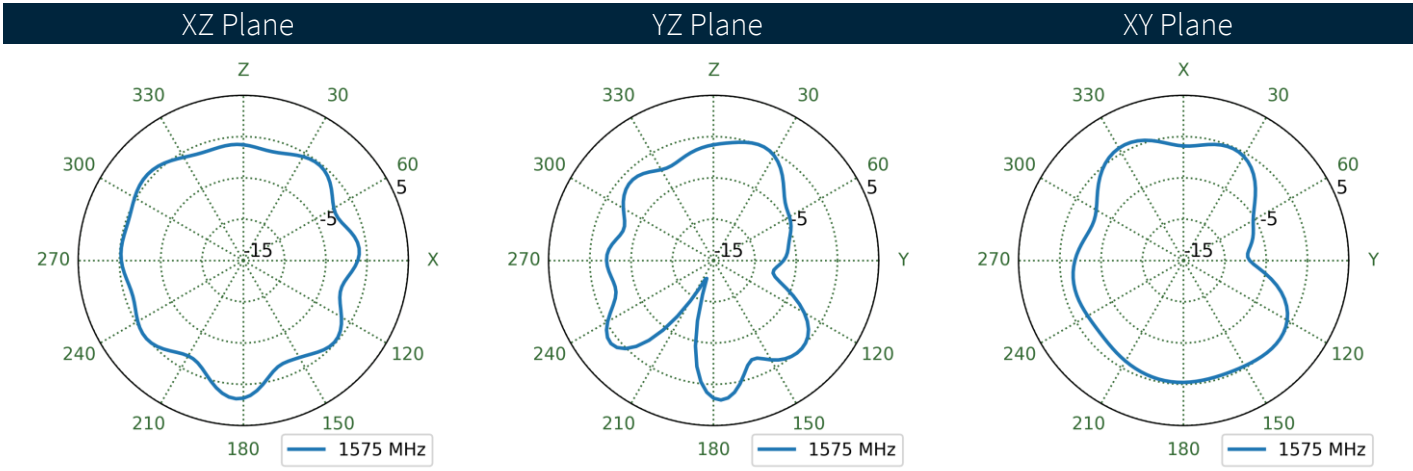
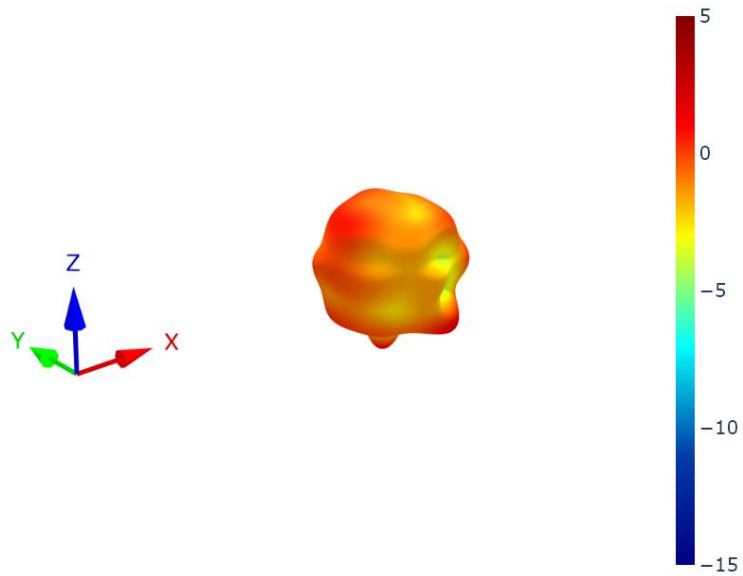

## 4.5 Patterns at 1603 MHz

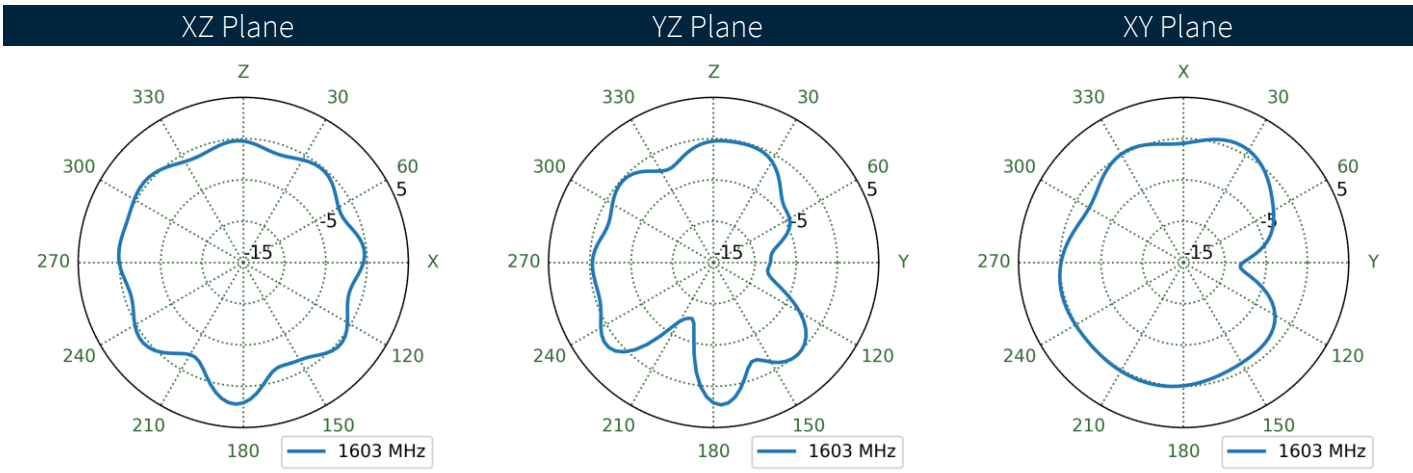
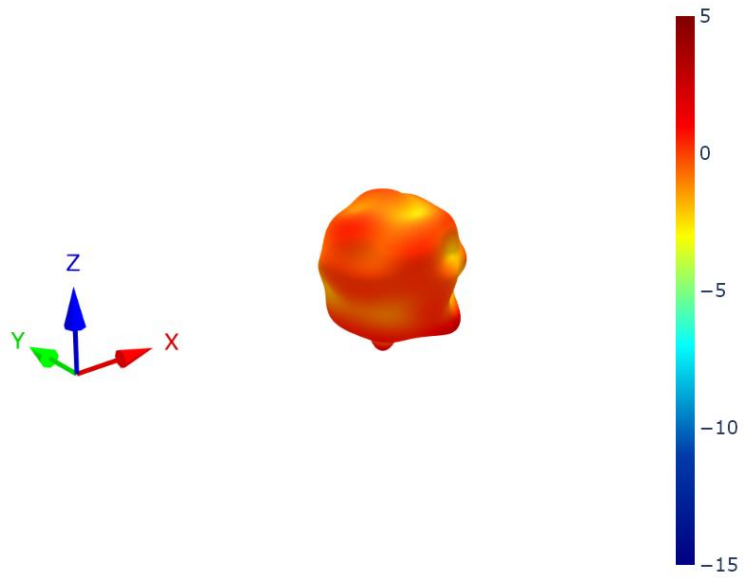

## 5. Active Circuitry Performance

### 5.1 Block Diagram

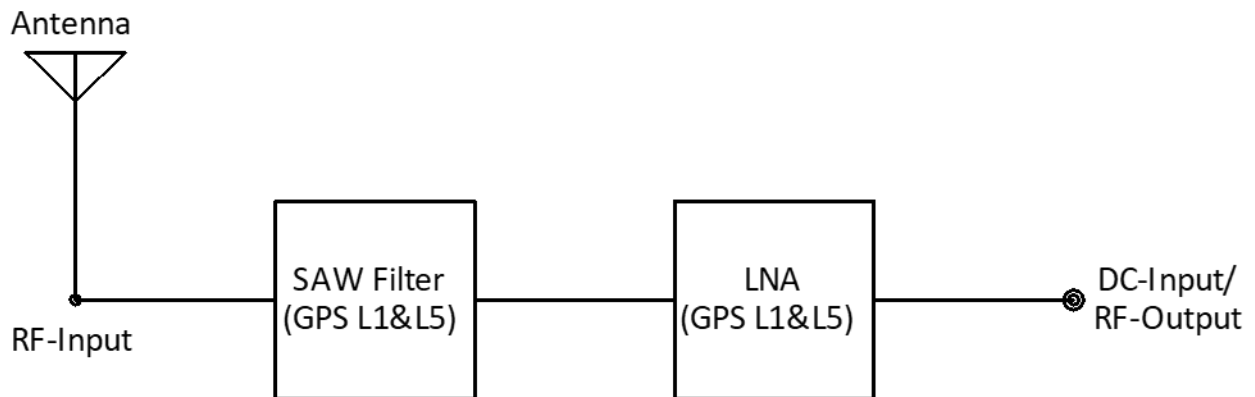

### 5.2 Combined LNA & SAW Filter Gain

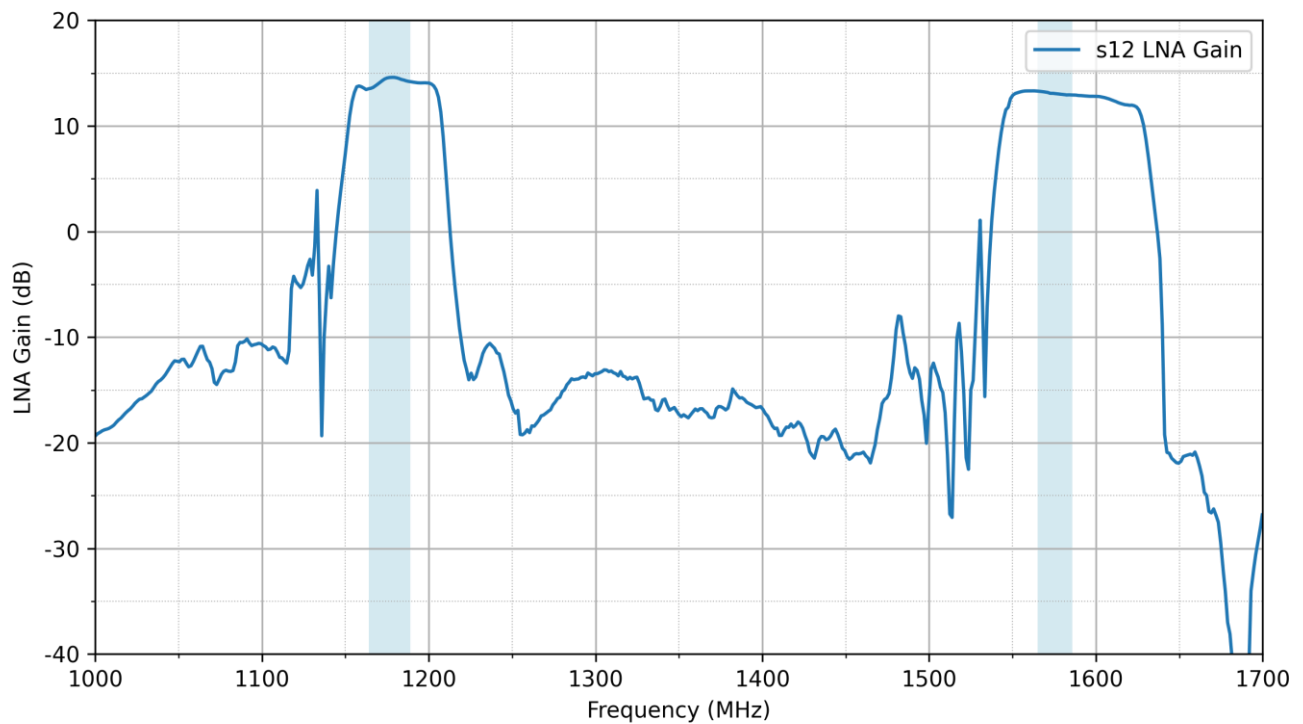

### 5.3 P1dB Compression Point (L1)

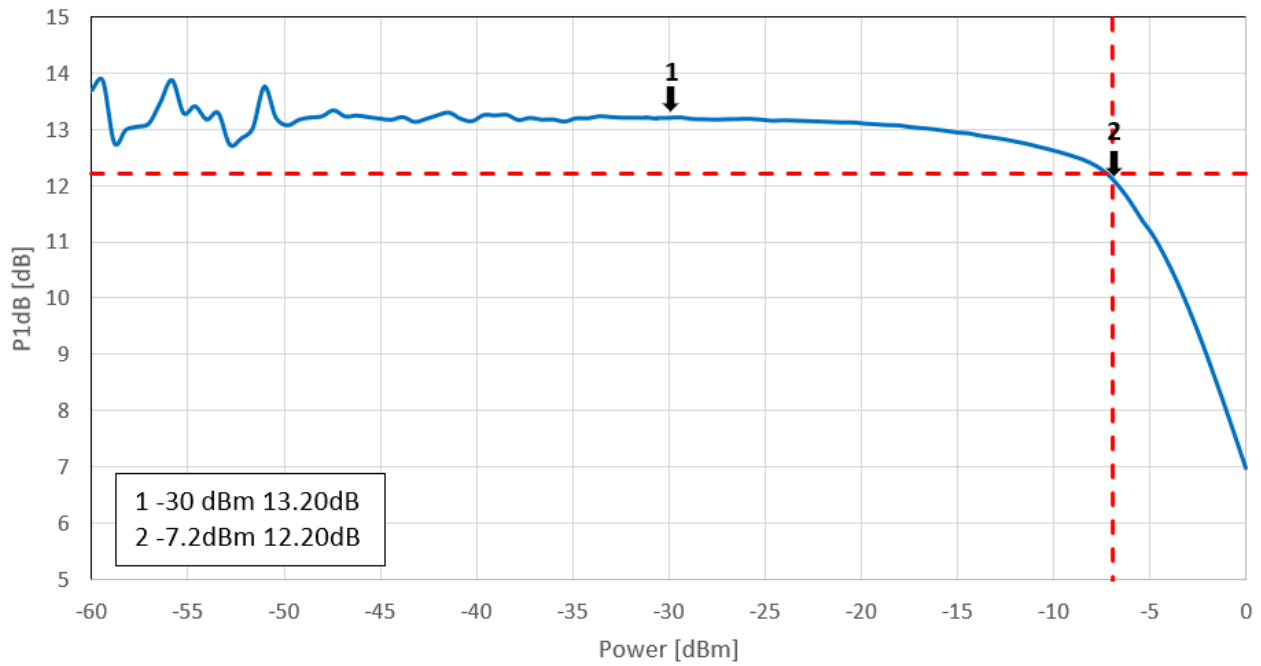

### 5.4 P1dB Compression Point (L5)

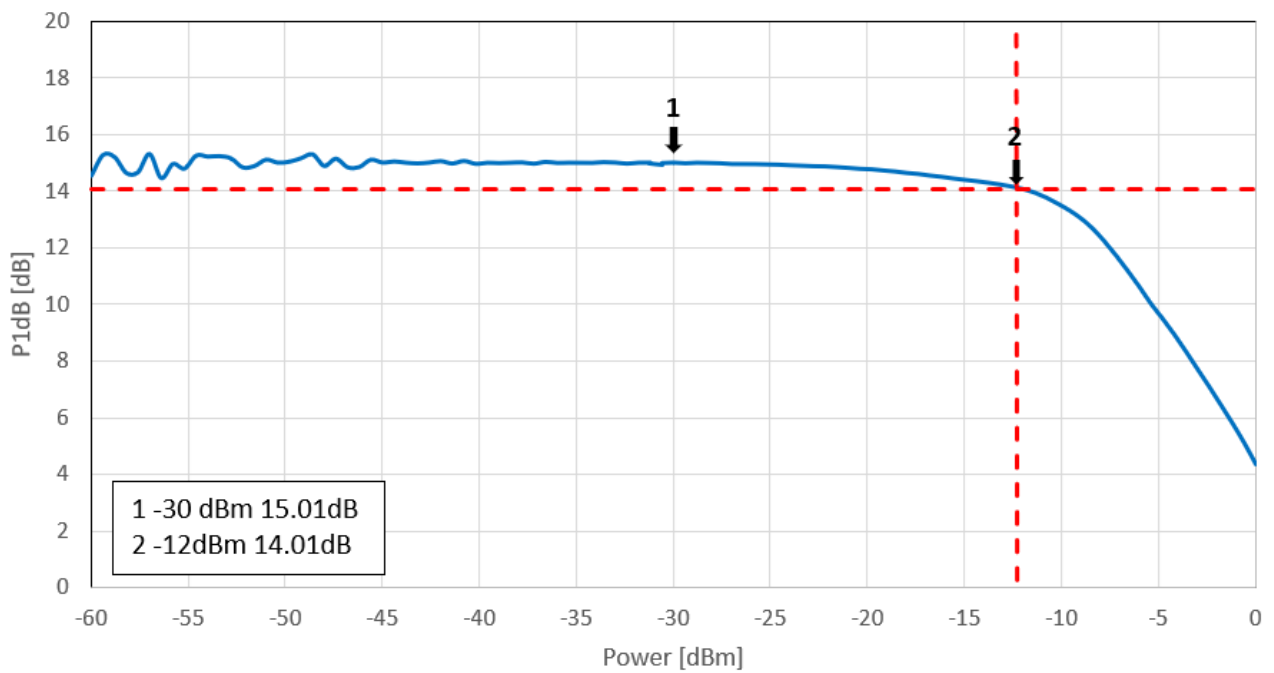



## 5.5 Noise Figure (L1)

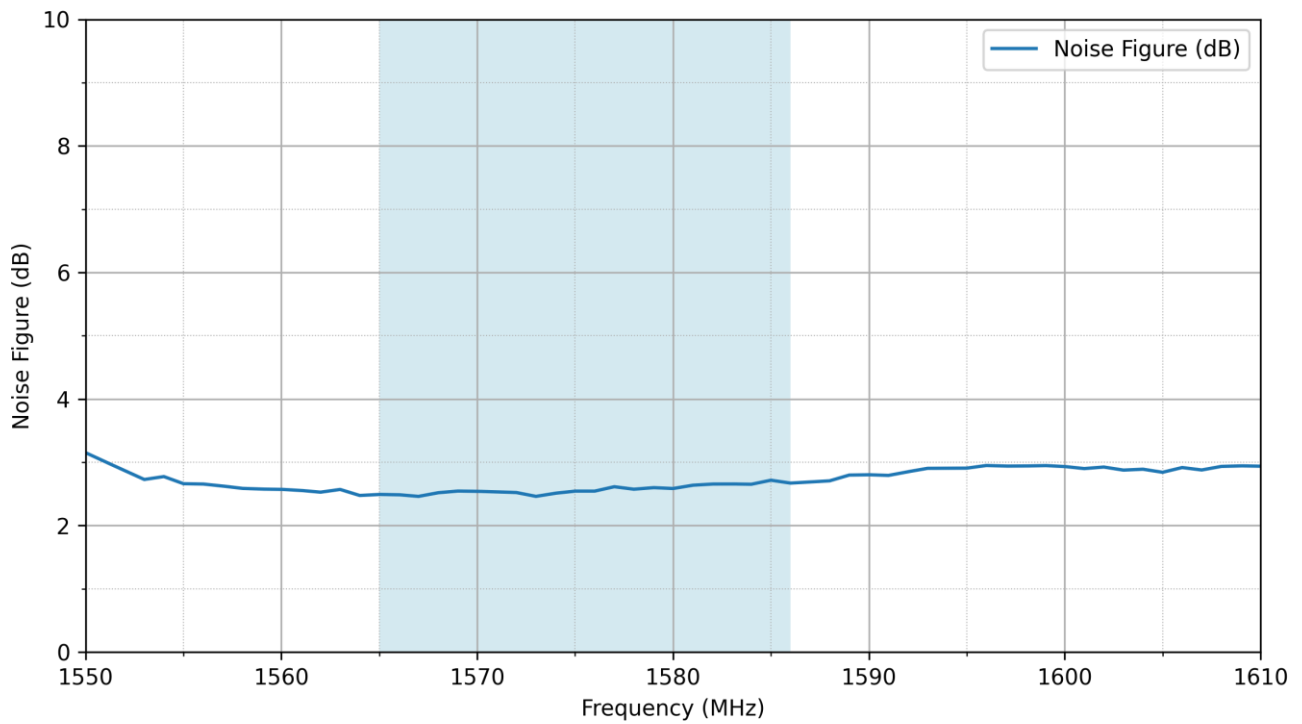

## 5.6 Noise Figure (L5)

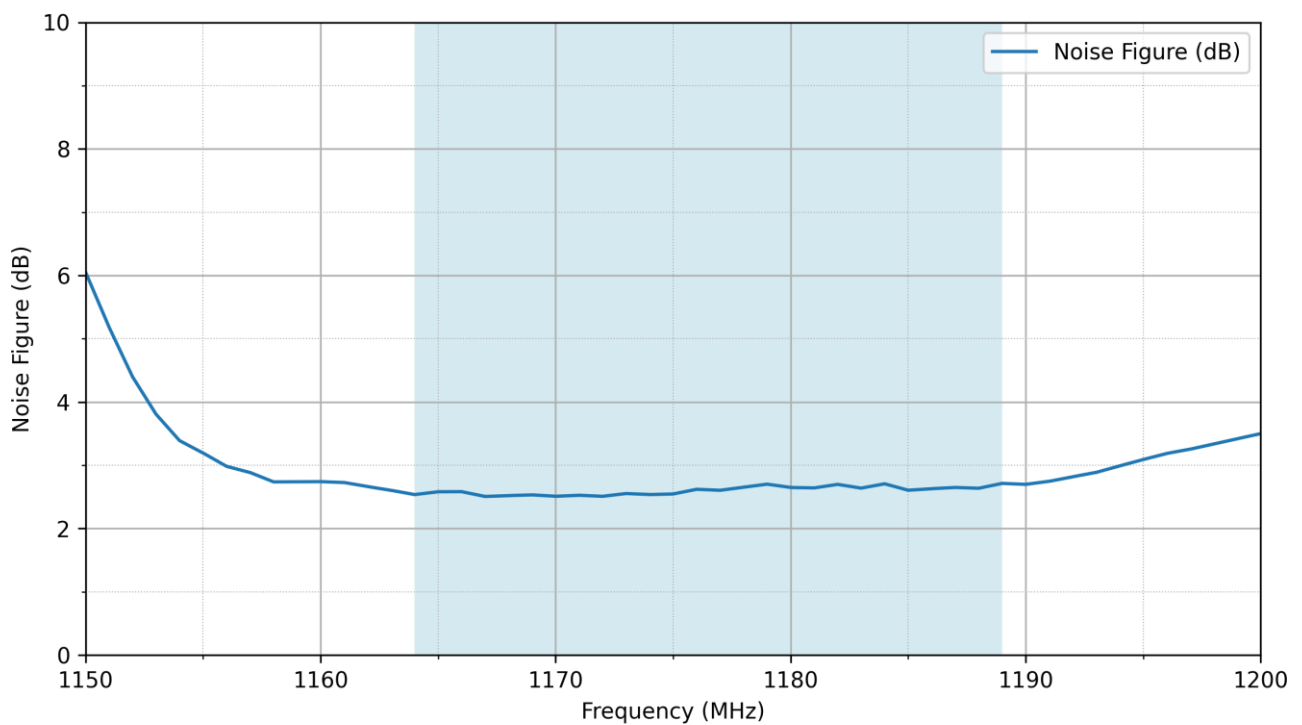

## 5.7 Group Delay (L1)

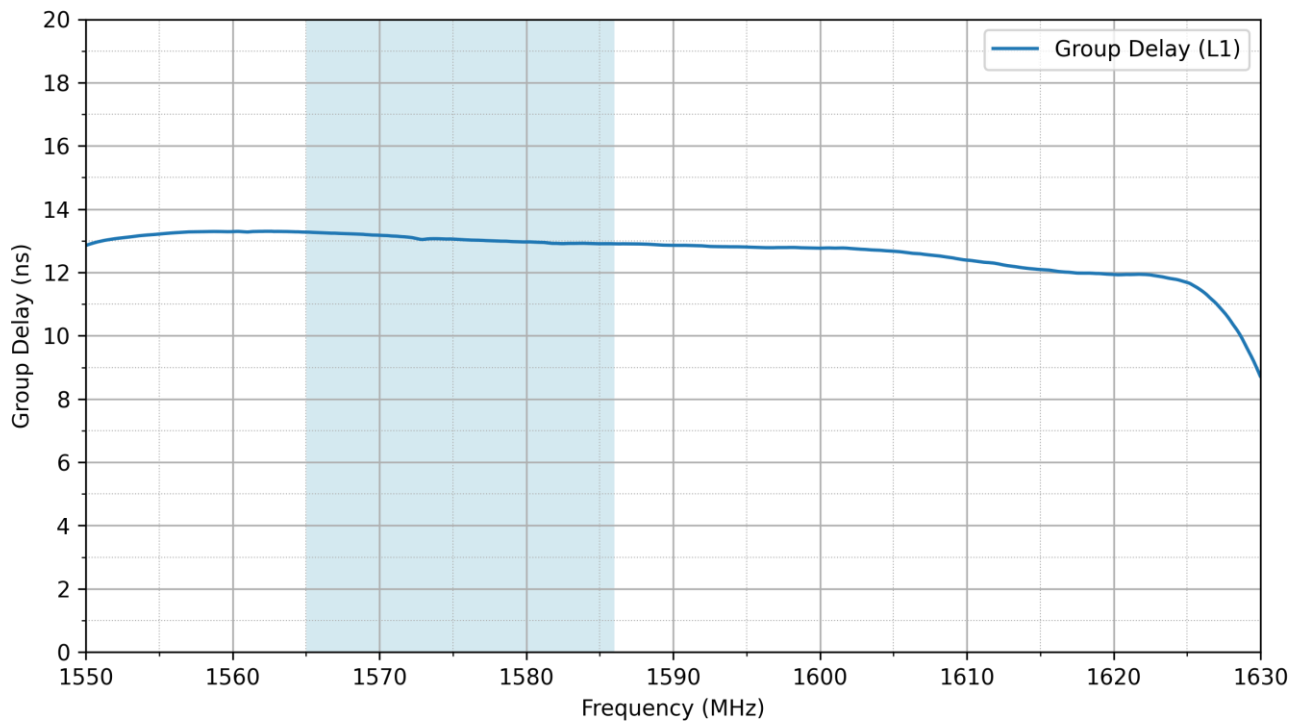

## 5.8 Group Delay (L5)

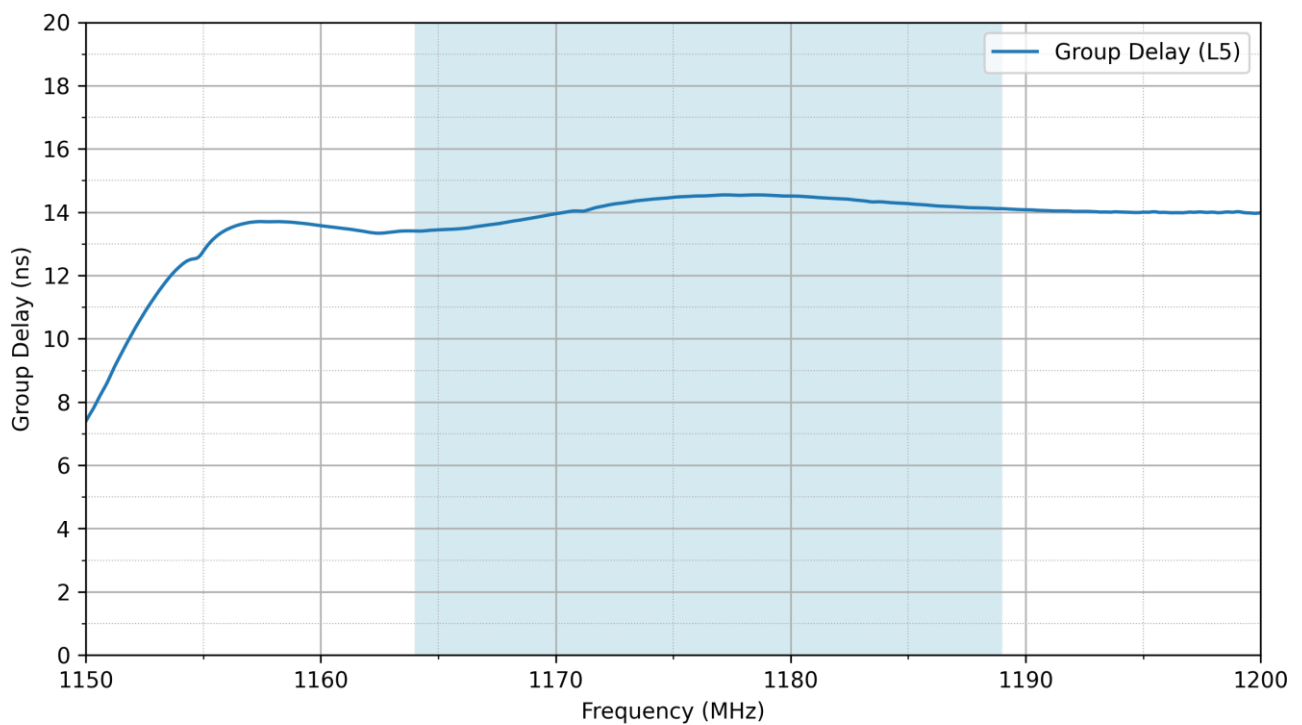

## 5.9 Out Of Band Rejection

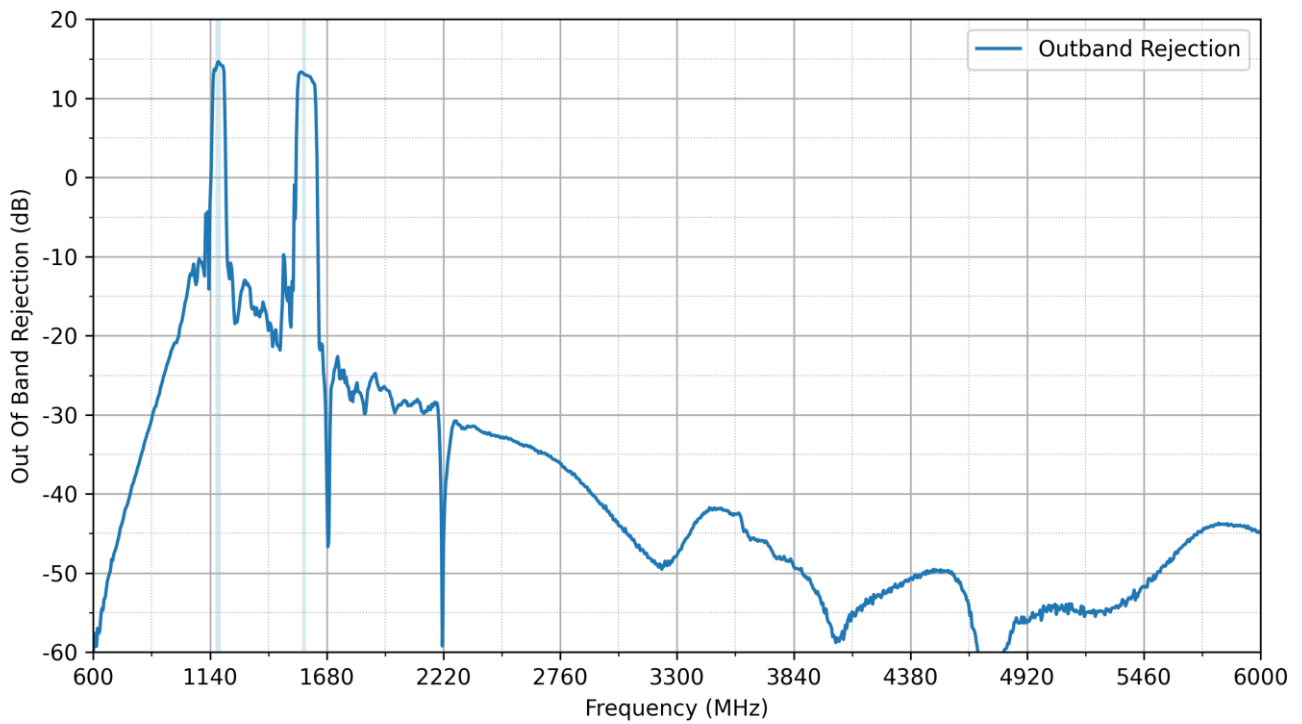

## 5.10 Combined System Gain

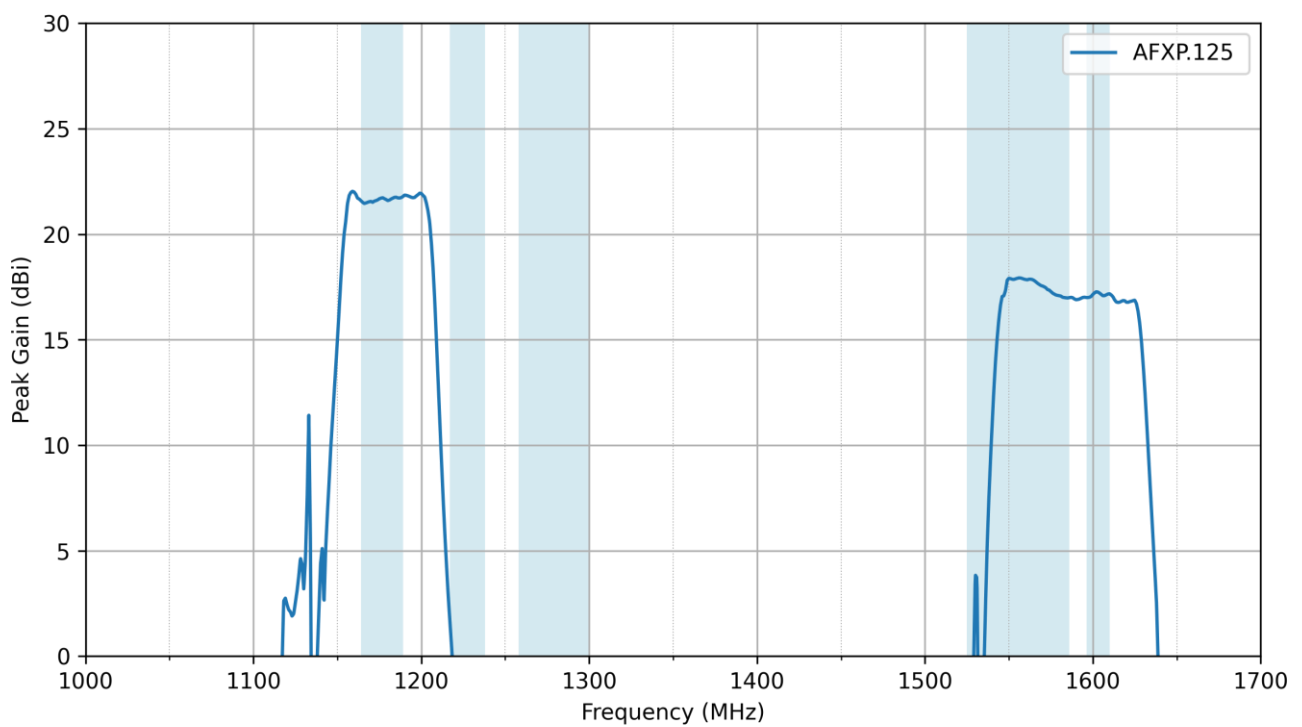

# 6. Mechanical Drawing

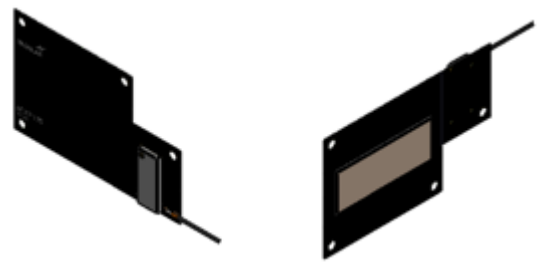
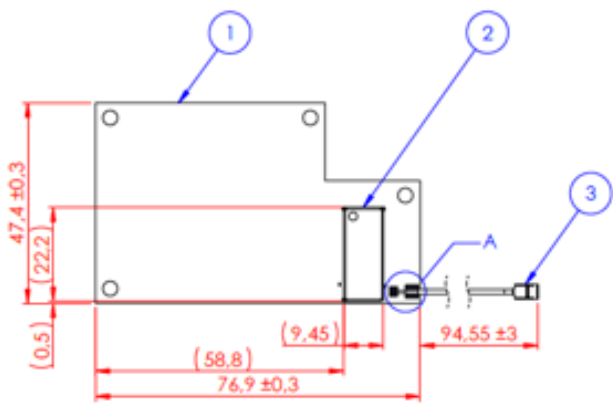
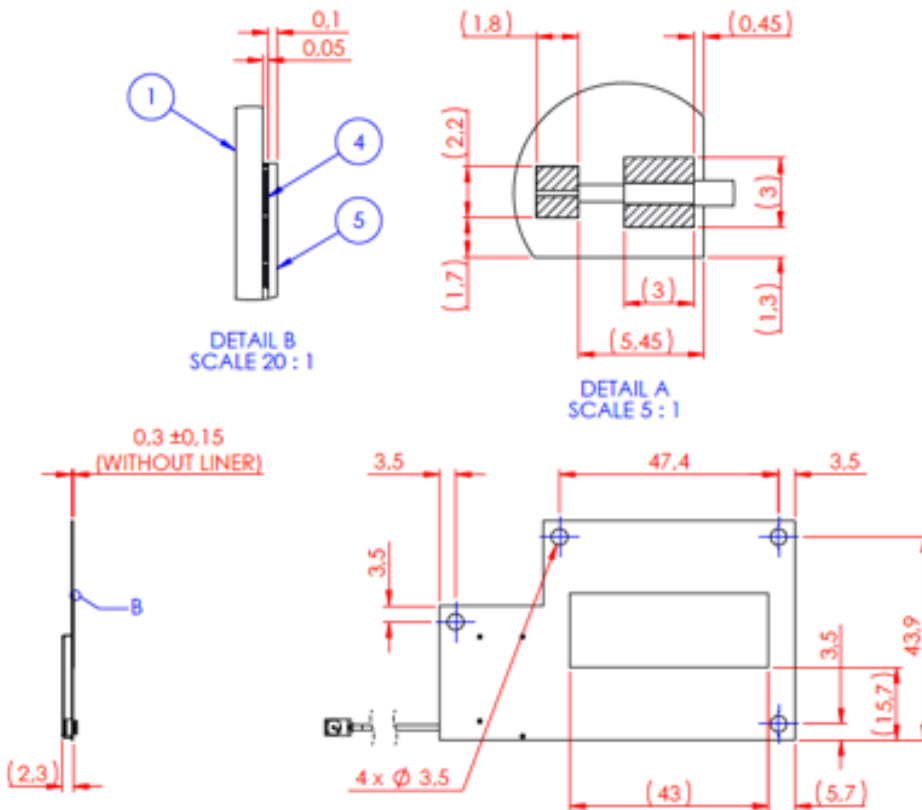

ITEM NO.	DESCRIPTION	QTY
1	GPS L1/L2/L5/L6 GLONASS BEI-DOU TRACE ANTENNA ON PCB	1
2	SHIELDING CASE SPTE TIN PLATED	1
3	IPEX I (U.FL COMPATIBLE) AU PLATED FOR 1.13 MICRO COAX (BLACK) 95mm, TIN/STRIP/OPEN (1.8/2/3), NO WINDING	1
4	ADHESIVE	1
5	LINER	1

## 7. Packaging

1pcs AFXP125 per Small PE Bag  
 Weight - 15g



2000pcs AFXP125 per carton  
 Dimensions - 370\*370\*300mm  
 Weight - 3Kg

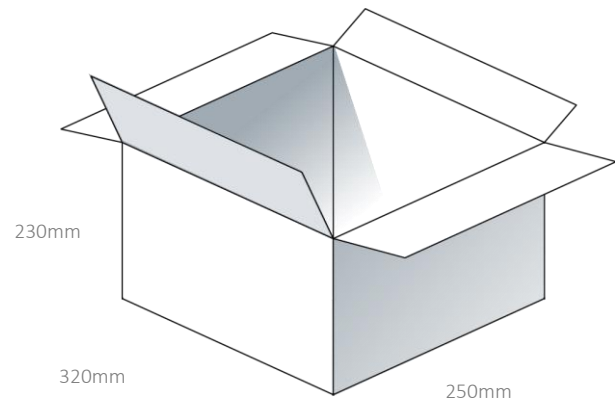

Changelog for the datasheet

**SPE-23-8-240– AFXP.125**

**Revision: A (Original First Release)**

Date:	2023-09-06
Notes:	Initial Release
Author:	Gary West

**Previous Revisions**



[www.taoglas.com](http://www.taoglas.com)

