



# TAOGLAS®

# Datasheet

## 90° Hinged Terminal Antenna

**Part No:**  
TG.62.A113

### Description

WideBand (600-7125MHz) Dipole IP67 Terminal Antenna with 90° Hinged R/A SMA(M)

### Features:

- Low-profile Housing with Wall Mount
- Worldwide 4G Bands including 3G and 2G
- IP67 Waterproof Enclosure
- Dimensions: Ø12.7 x 203mm
- Connector: SMA(M)
- Custom Cables and Connectors Available
- RoHS & Reach Compliant

<b>1.</b>	<b>Introduction</b>	<b>2</b>
<b>2.</b>	<b>Specification</b>	<b>3</b>
<b>3.</b>	<b>Antenna Characteristics</b>	<b>4</b>
<b>4.</b>	<b>Radiation Patterns</b>	<b>7</b>
<b>5.</b>	<b>Mechanical Drawing</b>	<b>29</b>
<b>6.</b>	<b>Packaging</b>	<b>30</b>
<hr/>		
	Changelog	31

Taoglas makes no warranties based on the accuracy or completeness of the contents of this document and reserves the right to make changes to specifications and product descriptions at any time without notice. Taoglas reserves all rights to this document and the information contained herein. Reproduction, use or disclosure to third parties without express permission is strictly prohibited.



# 1. Introduction



The Taoglas TG.62.8113 is a 5G/4G monopole antenna, designed primarily for use with modules and devices that require high efficiency and peak gain from a cellular antenna. It delivers best in class throughput on all major cellular bands worldwide, perfect for access points, terminals, and routers. The TG.62 covers all cellular bands from 600-6000MHz.

It has an SMA (M) connector as standard and is an ideal solution for any device requiring reliable performance in a slim form factor. The innovative hinge design not only provides flexibility when mounting the antenna, but its weatherproof, IP67 rating, means it be used in outdoor locations where potential water ingress would prevent other terminal mount antennas from being used.

Typical Applications include:

- Gateways & Routers
- Exterior Cameras
- Vending Machines
- Industrial IoT
- Smart Home
- Wastewater Monitoring

The TG.62 exhibits an efficiency of up to 80% across wideband 5G/4G bands and is backward compatible with 3G/2G cellular applications. The TG.62 is a fully omnidirectional antenna as seen in the radiation patterns and is stable across all bands, ideal for applications requiring reliable throughput.

The SMA (M) connector hinge mechanism allows the antenna to be rotated into the preferred orientation which helps to avoid objects or other antennas. This helps with antenna isolation by pointing them in alternate directions when using multiple antennas in MIMO systems or devices. The antenna blade can swivel 90 degrees from the connector accommodating different installation configurations.

Contact your regional Taoglas customer support team to request testing services or additional support to integrate and test this antenna’s performance in your device.

## 2. Specification

LTE Electrical							
Frequency (MHz)	Test Set-up	Efficiency (%)	Average Gain (dB)	Peak Gain (dBi)	Impedance	Polarization	Radiation Pattern
617-960	Free space	44.4	-3.52	2.87	50 $\Omega$	Linear	Omni
	on 15x9 Ground	70.4	-1.52	3.34			
	on 9x15 Ground	75.3	-1.23	4.63			
1710-2700	Free space	37.2	-4.30	1.39			
	on 15x9 Ground	56.3	-2.49	5.00			
	on 9x15 Ground	57.6	-2.40	5.23			
3300-3800	Free space	58.7	-2.31	1.45			
	on 15x9 Ground	56.6	-2.48	5.77			
	on 9x15 Ground	51.6	-2.87	4.83			
4400-5000	Free space	40.1	-3.97	2.55			
	on 15x9 Ground	43.5	-3.61	4.36			
	on 9x15 Ground	43.8	-3.58	3.10			
5850-5850	Free space	58.3	-2.35	3.53			
	on 15x9 Ground	41.4	-3.83	3.15			
	on 9x15 Ground	45.5	-3.42	3.30			
5925-7125	Free space	46.8	-3.06	3.87			
	on 15x9 Ground	37.6	-4.11	5.52			
	on 9x15 Ground	37.2	-5.38	5.03			

Mechanical	
Dimensions	$\varnothing$ 12.7 x 203mm
Material	PC+PBT
Connector	SMA(M)

Environmental	
Operation Temperature	-40°C - +85°C
Storage Temperature	-40°C - +85°C

### 3. Antenna Characteristics

#### 3.1 Test Set-up

AUT



Vector Network Analyzer

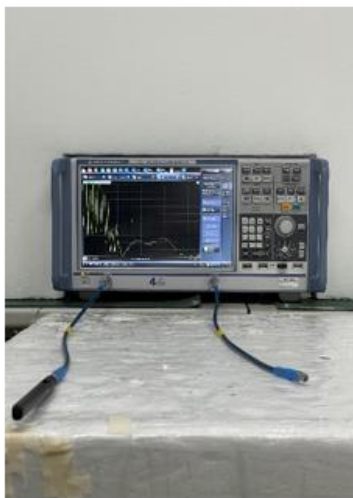

Free Space

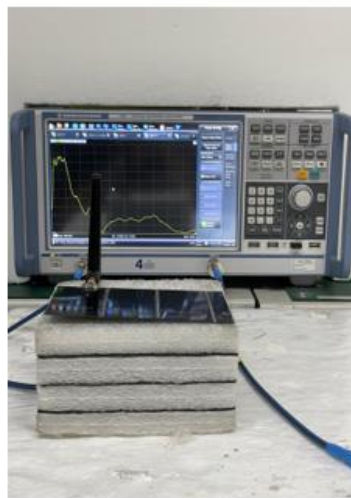

On 15x9cm Ground



On 9x15cm Ground

### 3.2 Return Loss

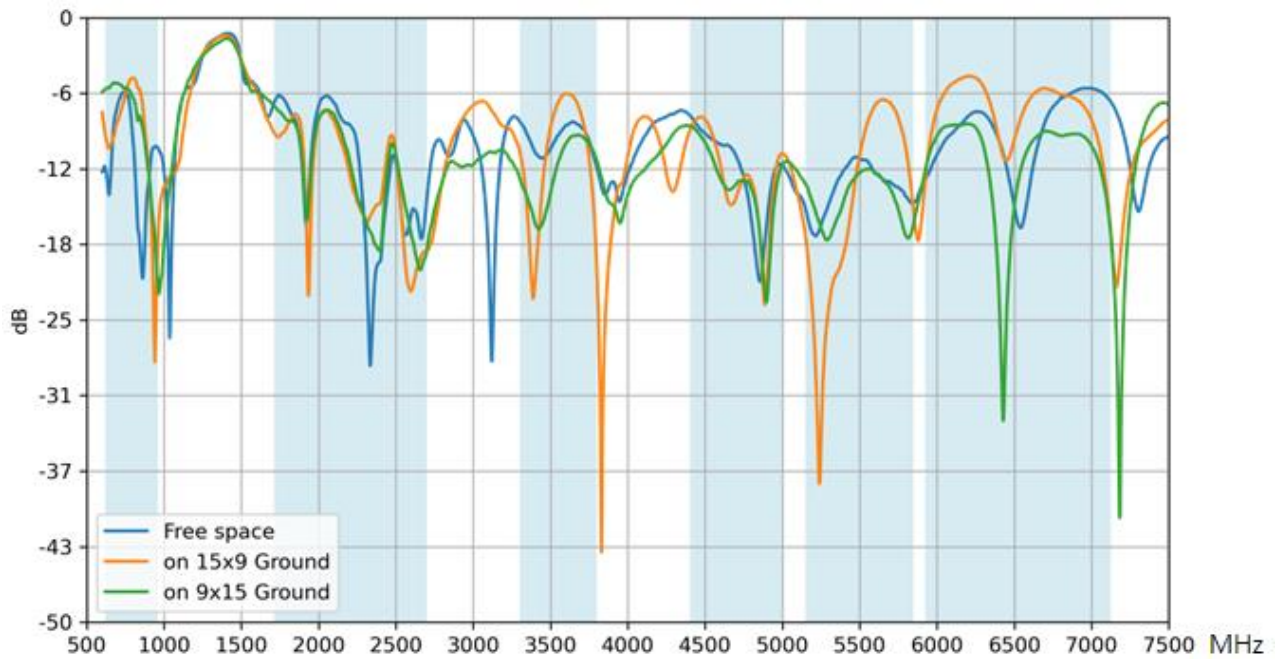

### 3.3 Efficiency



### 3.4 Average Gain

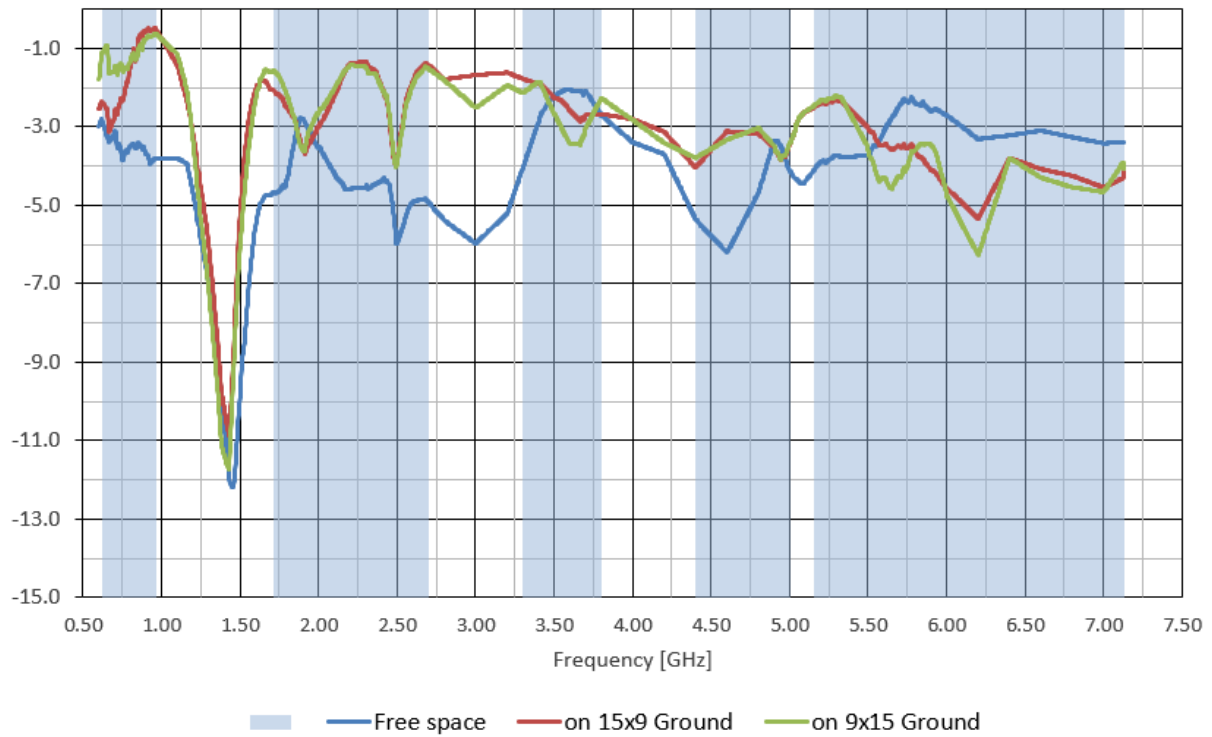

### 3.5 Peak Gain

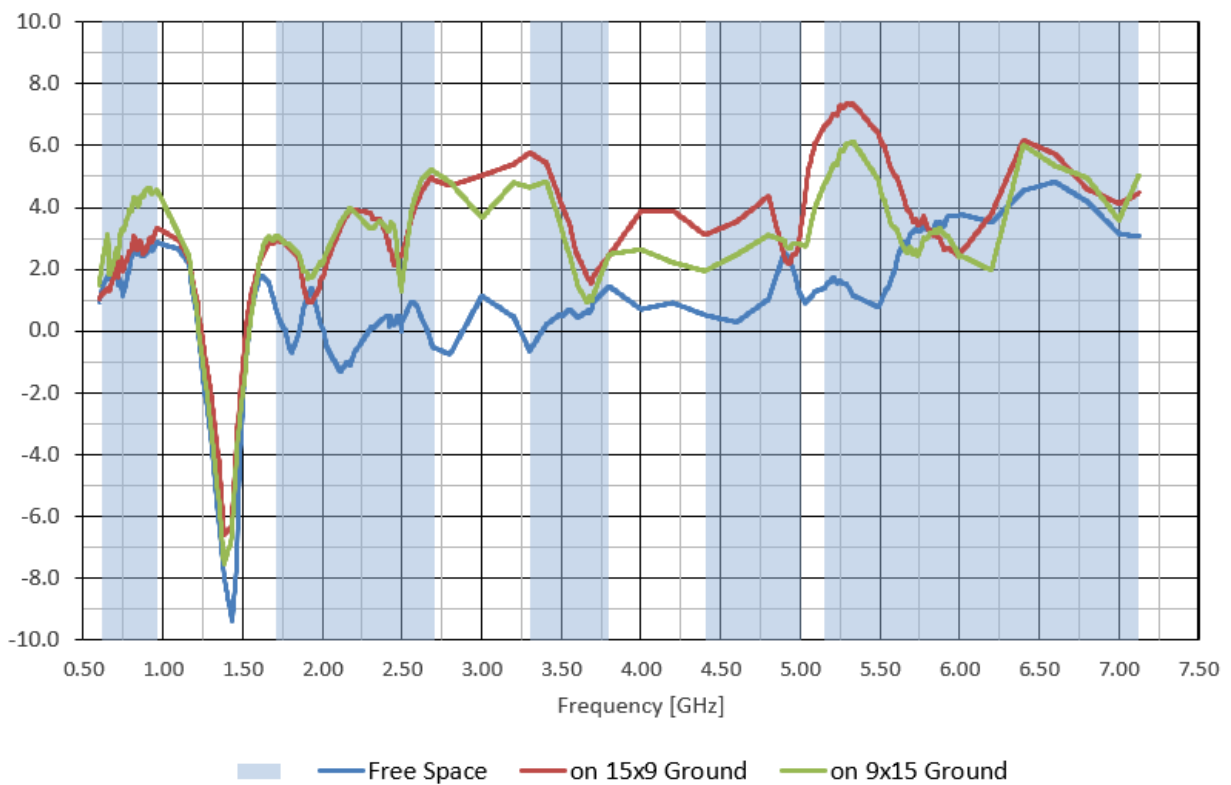

## 4. Radiation Patterns

### 4.1 Test Setup

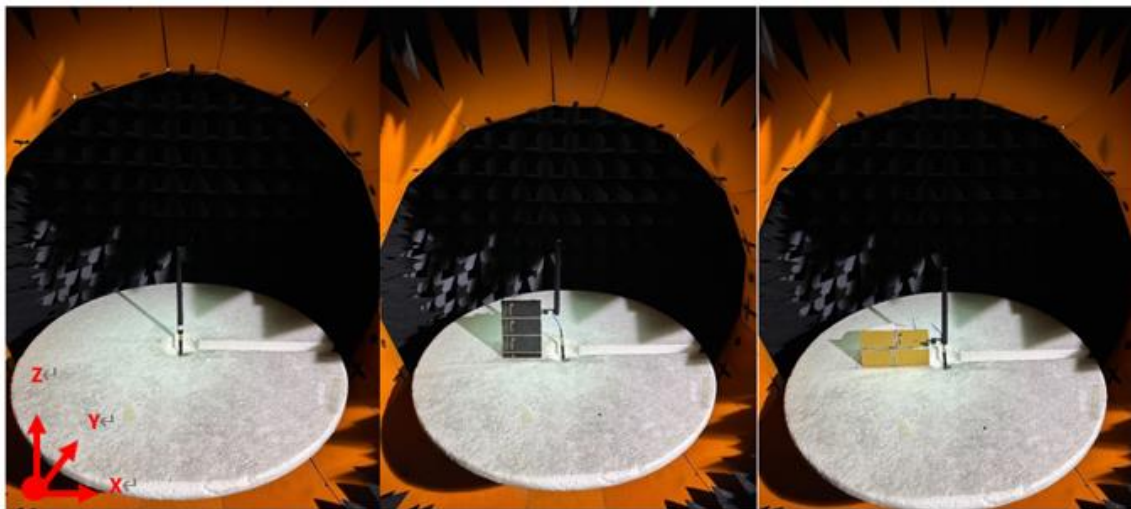
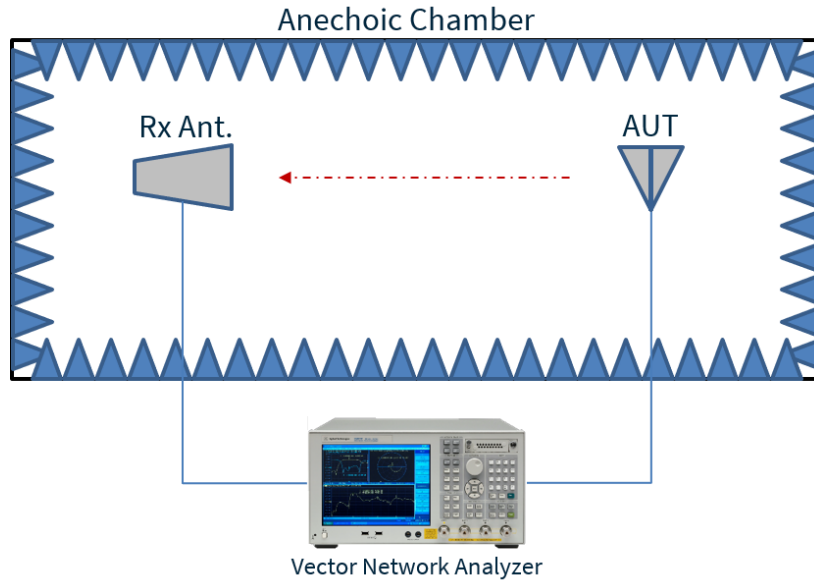

Free Space

On 15x9cm Ground

On 9x15cm Ground



4.2 Free space - Patterns at 824 MHz

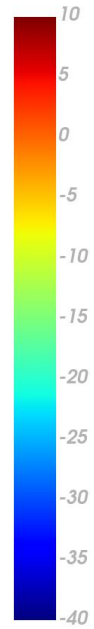
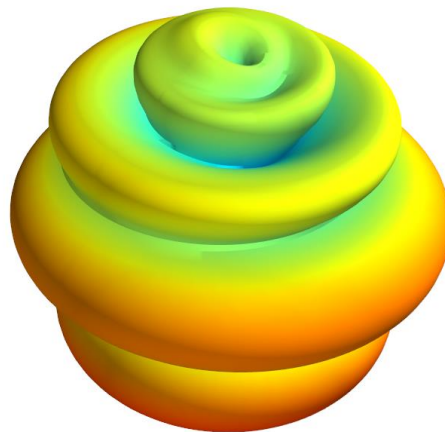

XZ Plane      YZ Plane      XY Plane

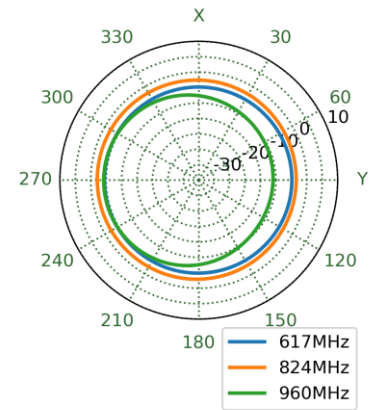
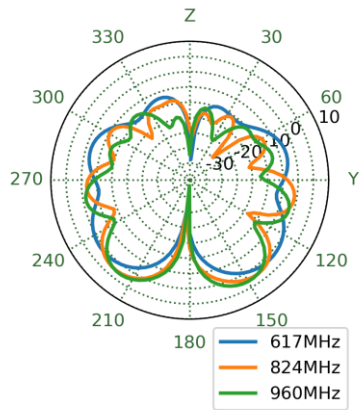
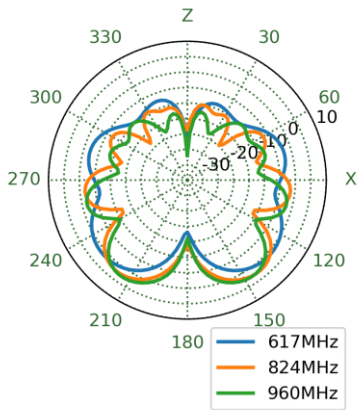

4.3 Free space - Patterns at 2170 MHz

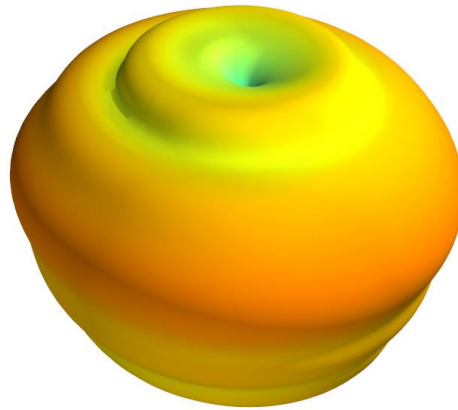

XZ Plane

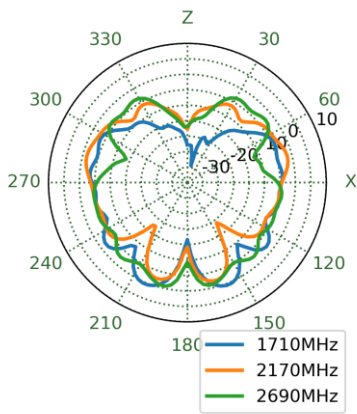

YZ Plane

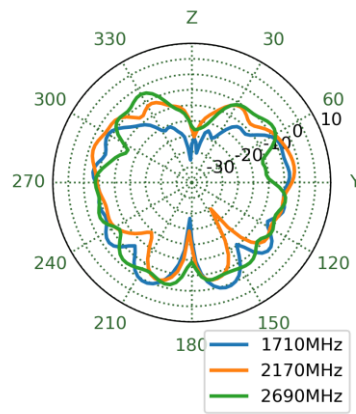

XY Plane

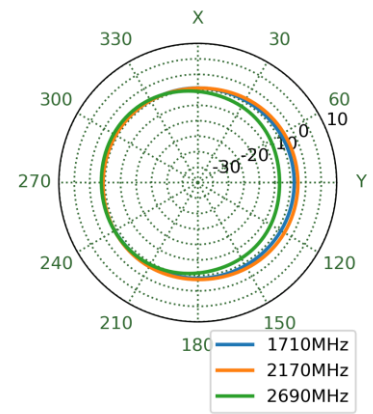

4.4 Free space - Patterns at 3550 MHz

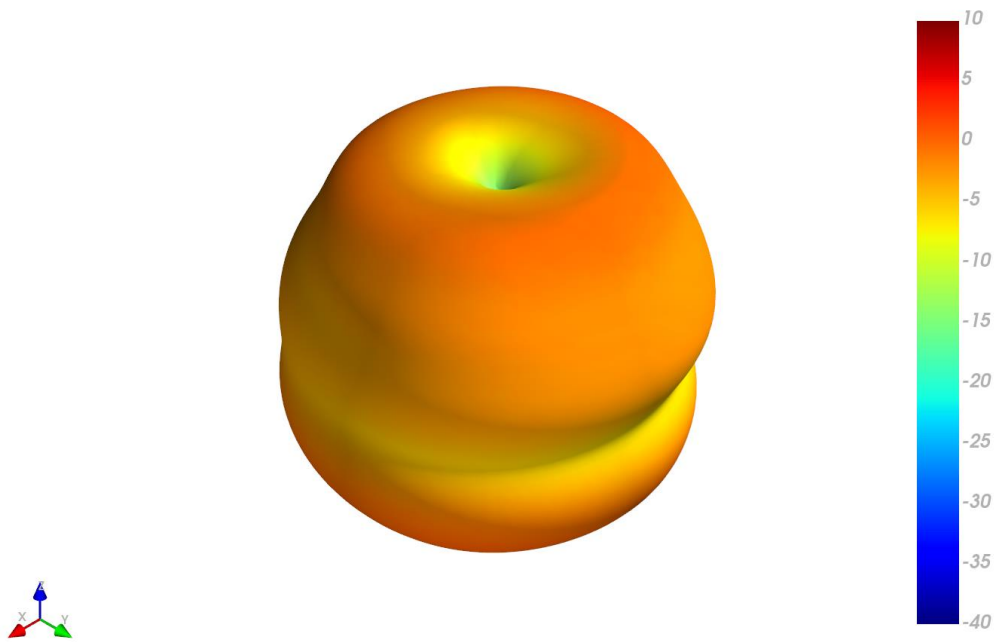

XZ Plane                      YZ Plane                      XY Plane

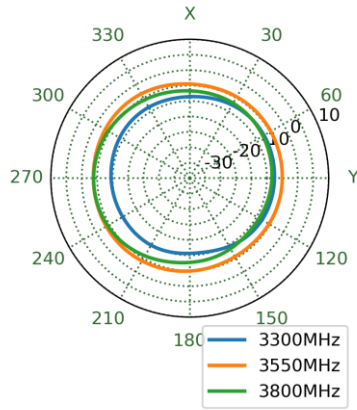
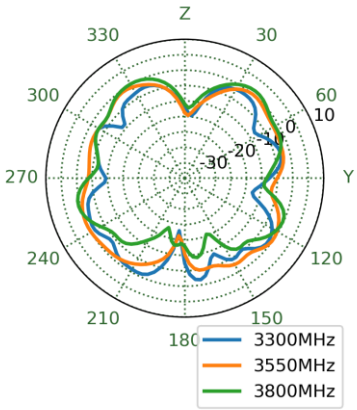
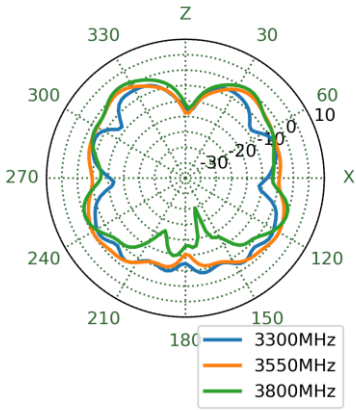

4.5 Free space - Patterns at 4600 MHz

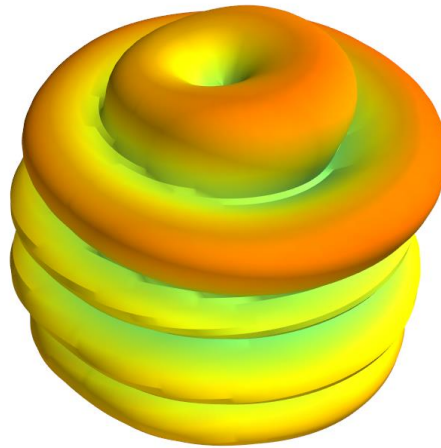

XZ Plane      YZ Plane      XY Plane

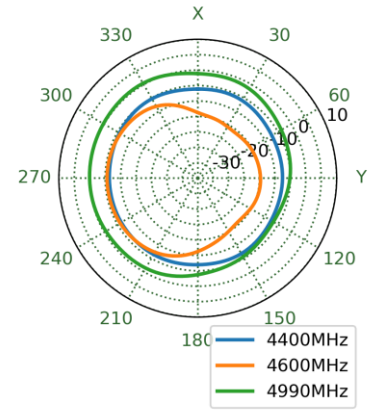
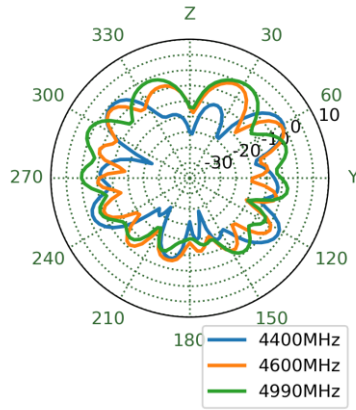
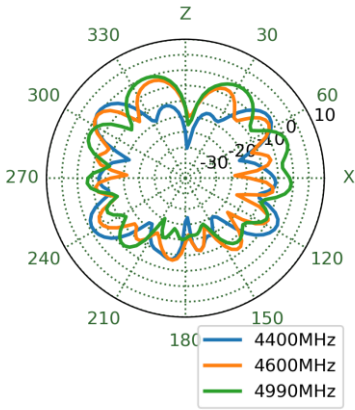

4.6 Free space - Patterns at 5490 MHz

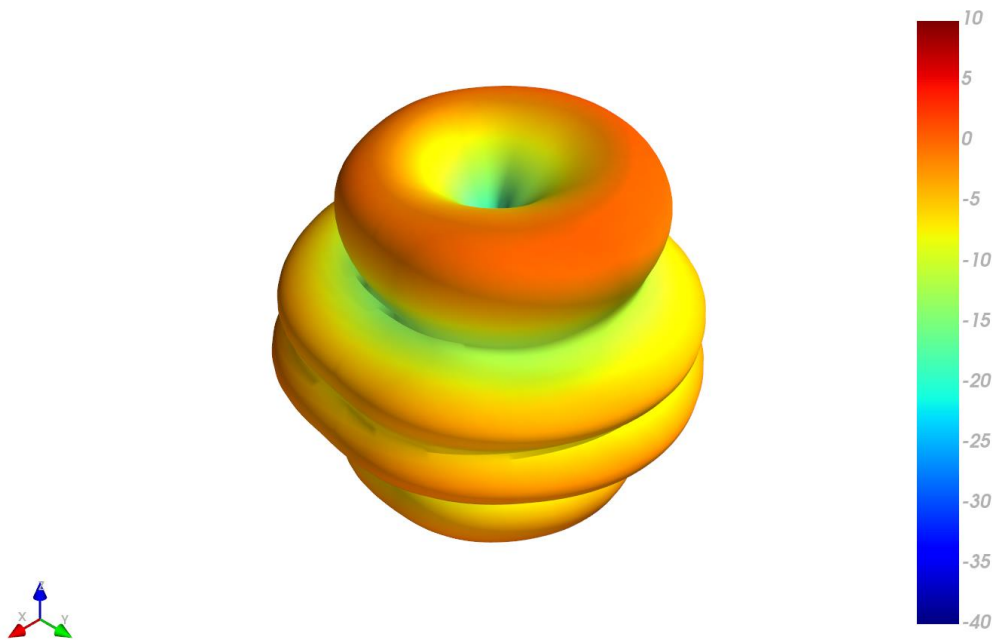

XZ Plane      YZ Plane      XY Plane

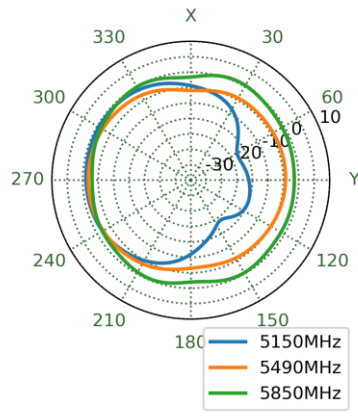
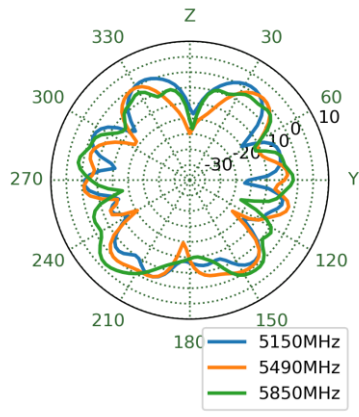
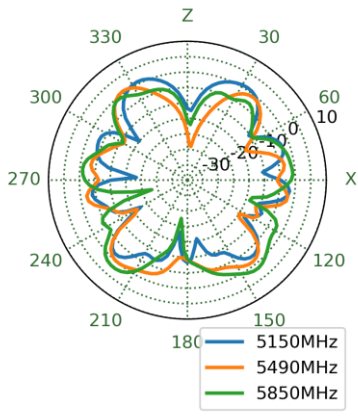

4.7 Free space - Patterns at 6000 MHz

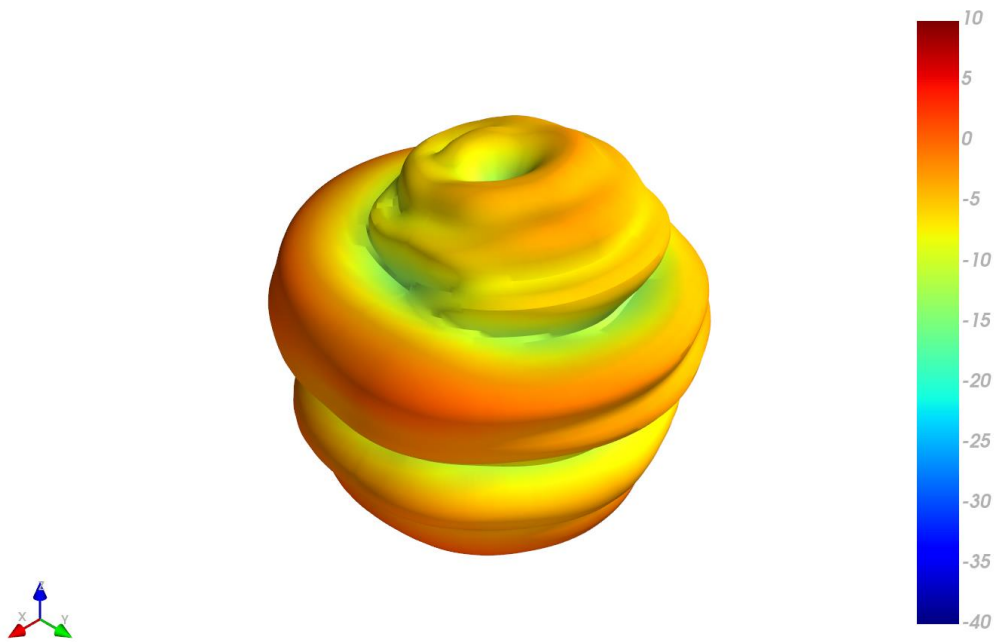

XZ Plane      YZ Plane      XY Plane

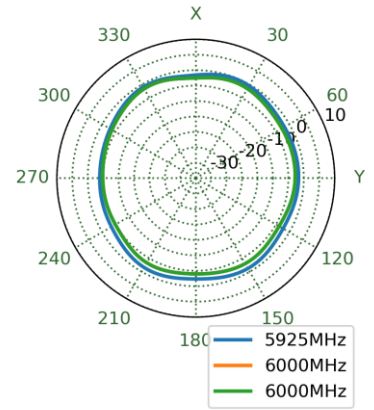
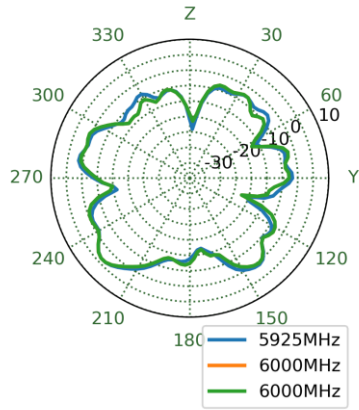
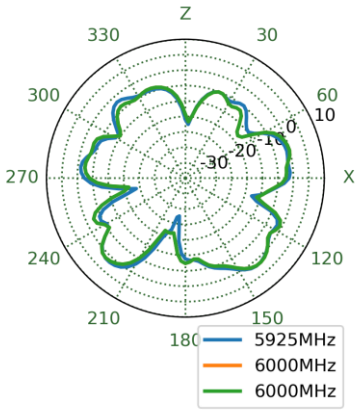

4.8 Free space - Patterns at 6600 MHz

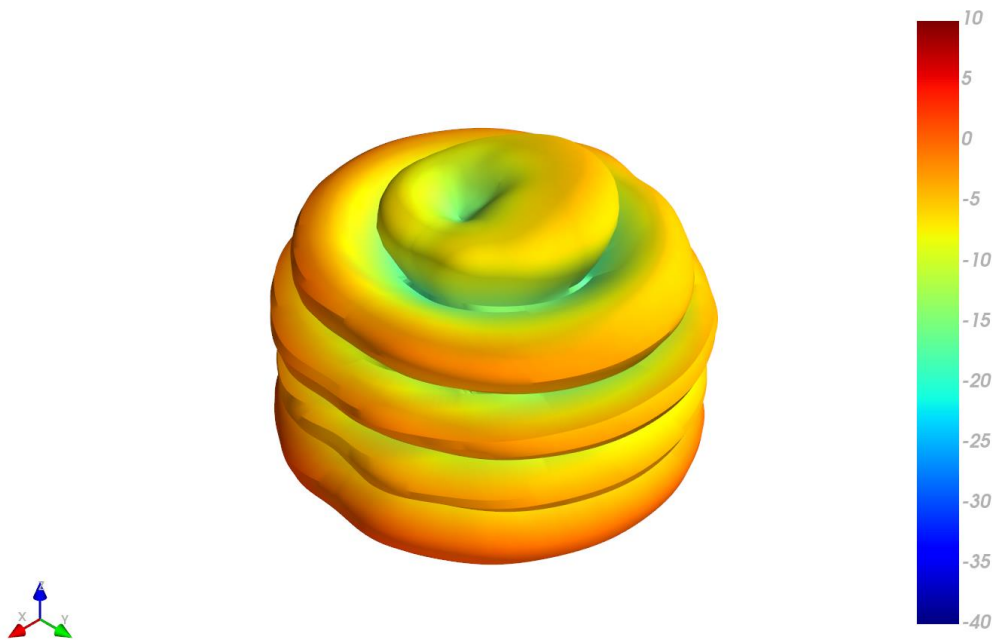

XZ Plane                      YZ Plane                      XY Plane

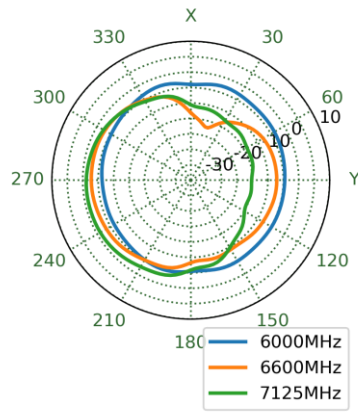
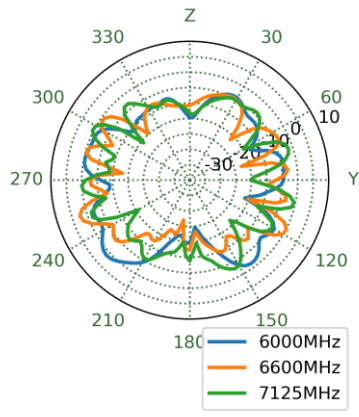
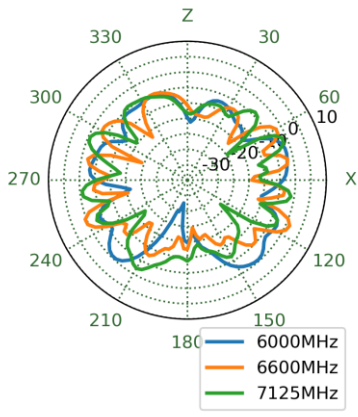

4.9 On 15x9cm Ground - Patterns at 824 MHz

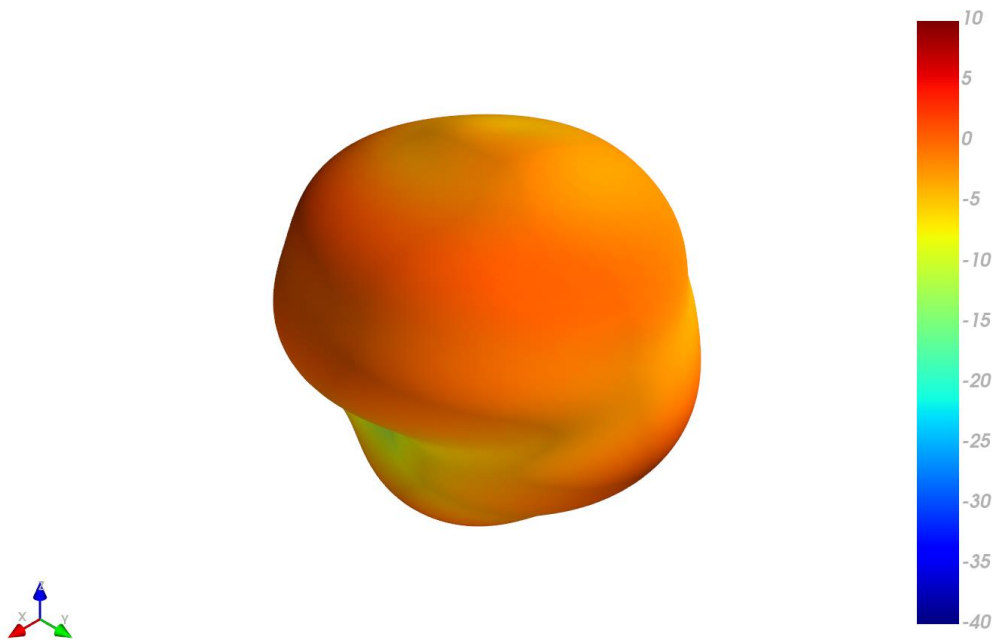

XZ Plane                      YZ Plane                      XY Plane

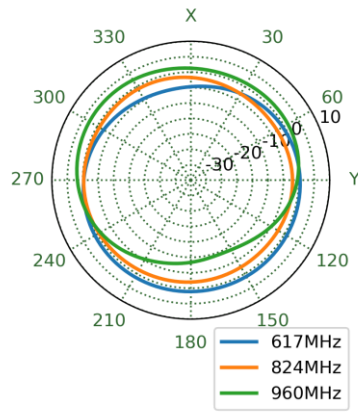
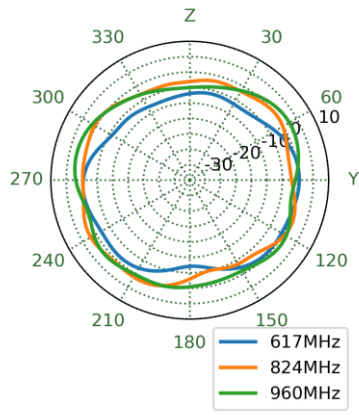
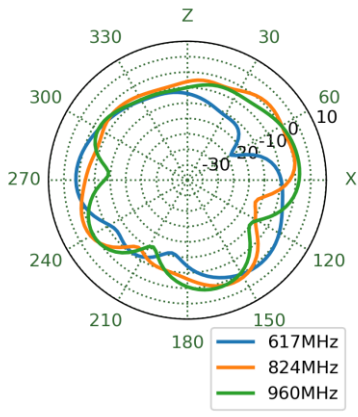



4.10 On 15x9cm Ground - Patterns at 2170 MHz

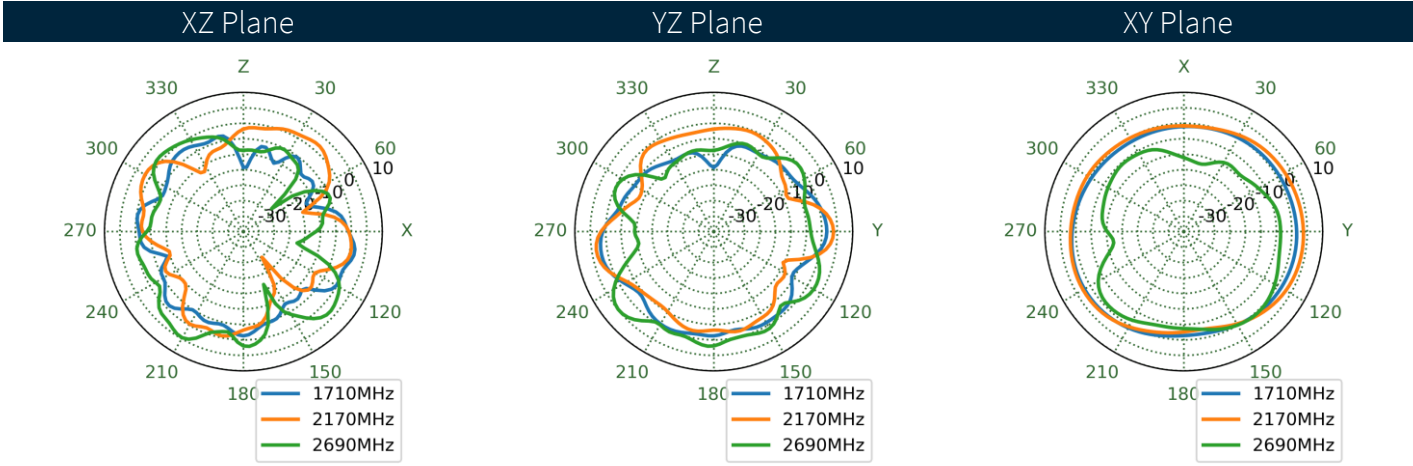
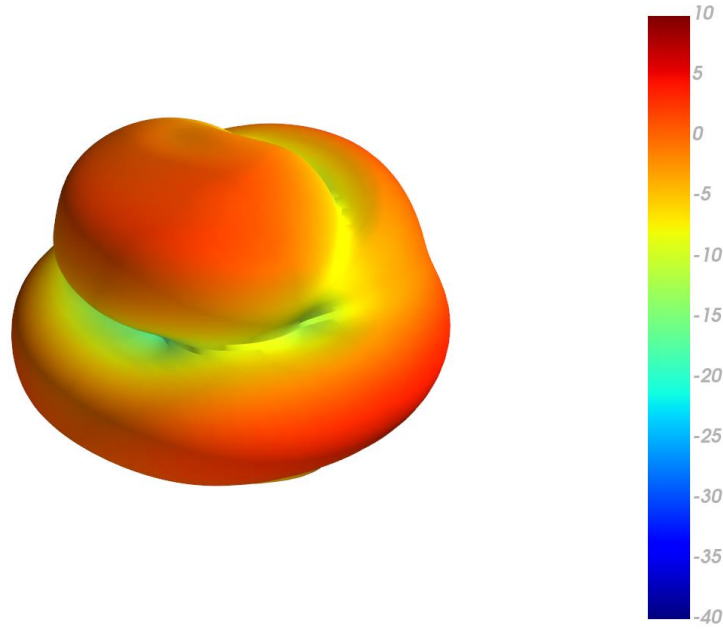

4.11 On 15x9cm Ground - Patterns at 3550 MHz

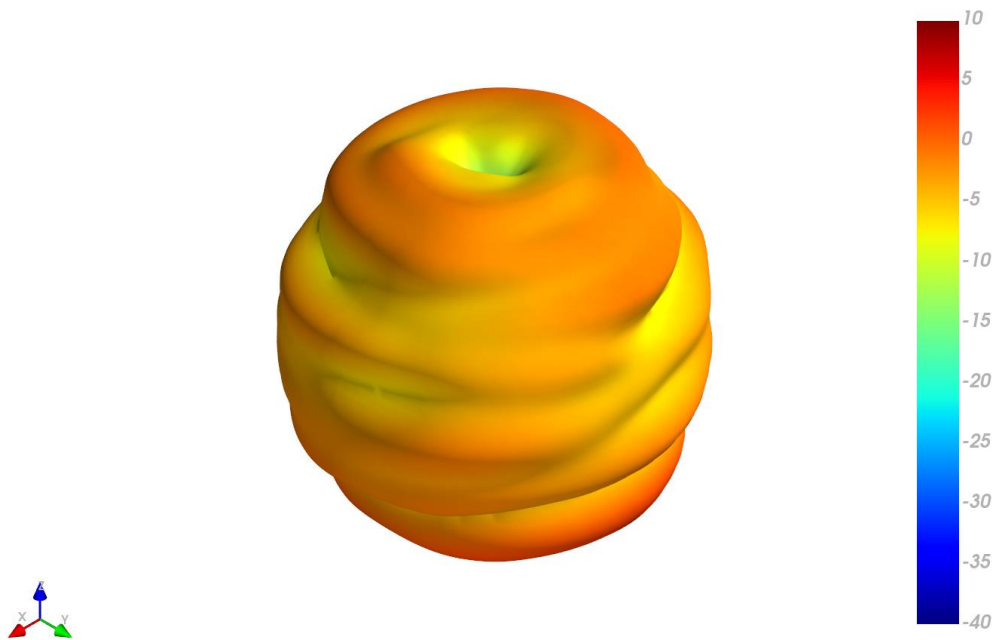

XZ Plane                      YZ Plane                      XY Plane

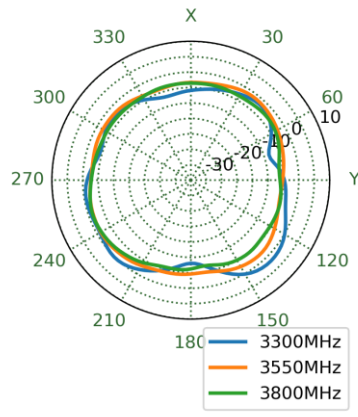
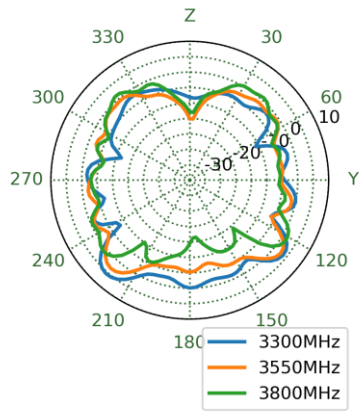
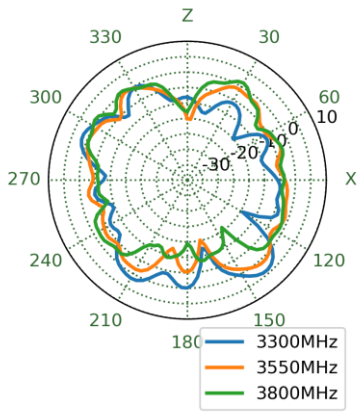

4.12 On 15x9cm Ground - Patterns at 4600 MHz

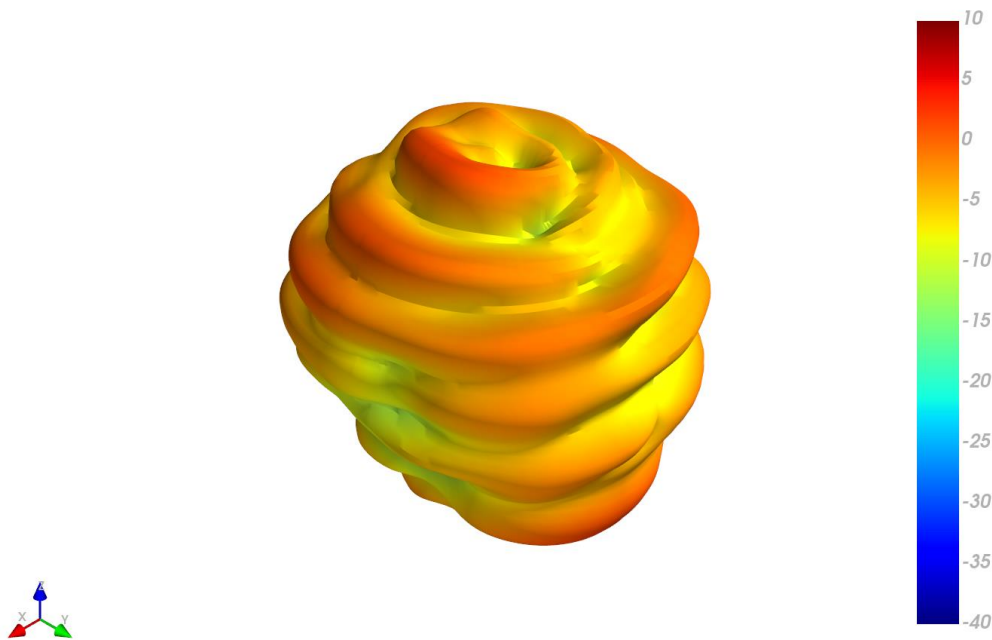

XZ Plane                      YZ Plane                      XY Plane

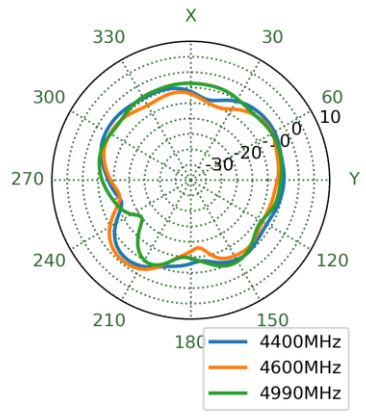
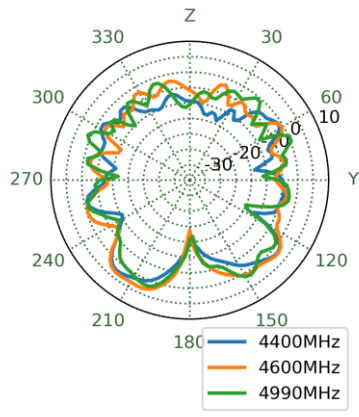
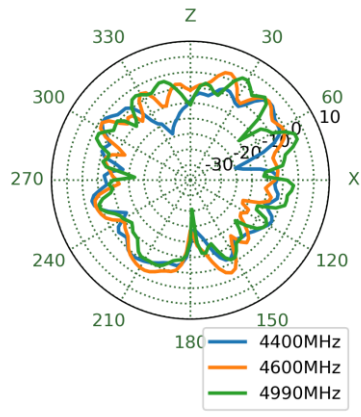

4.13 On 15x9cm Ground - Patterns at 5490 MHz

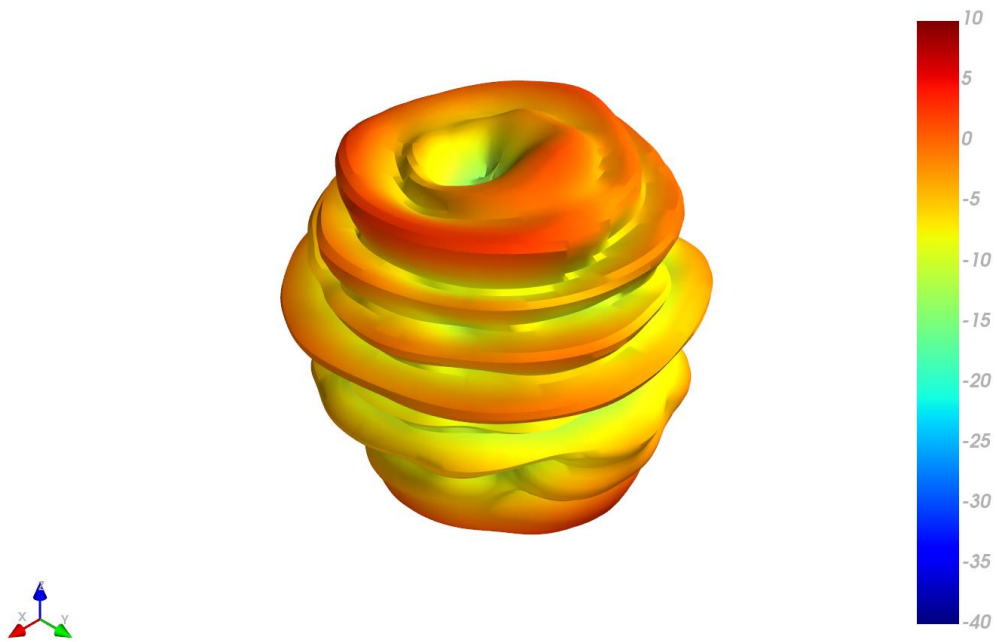

XZ Plane                      YZ Plane                      XY Plane

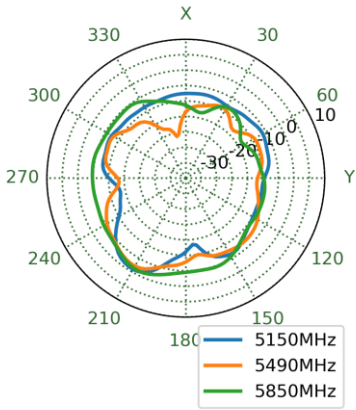
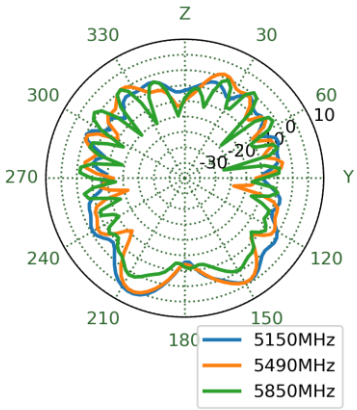
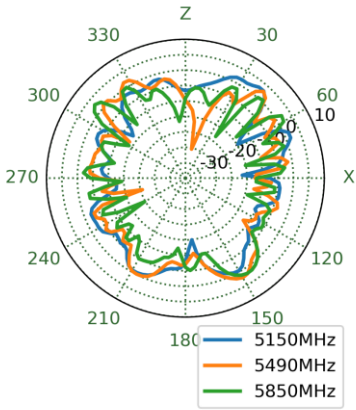

4.14 On 15x9cm Ground - Patterns at 6000 MHz

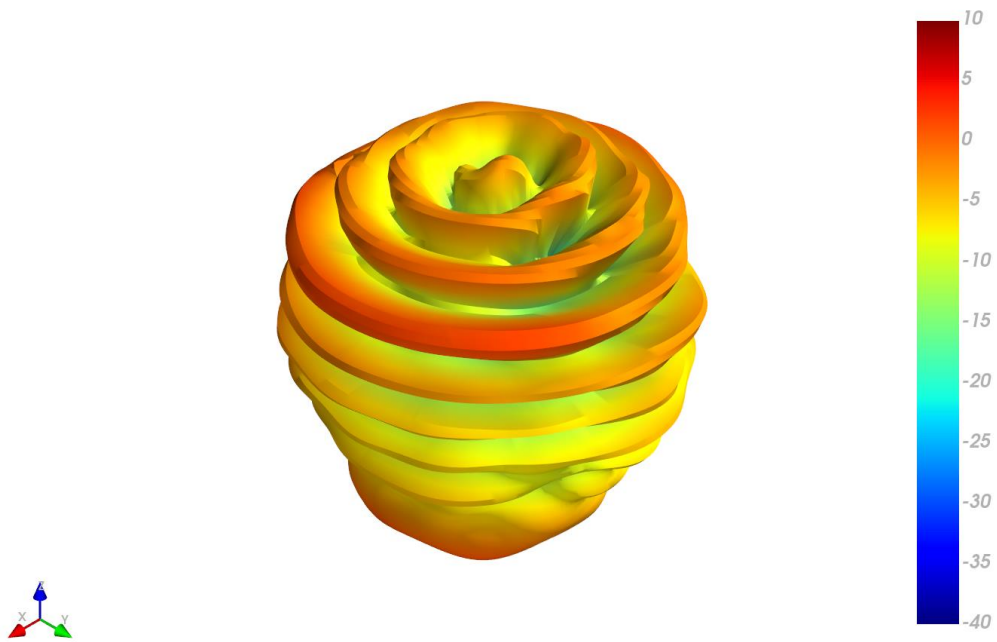

XZ Plane                      YZ Plane                      XY Plane

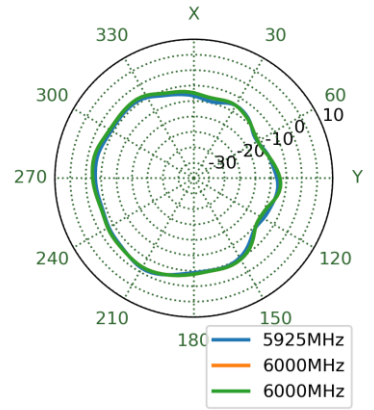
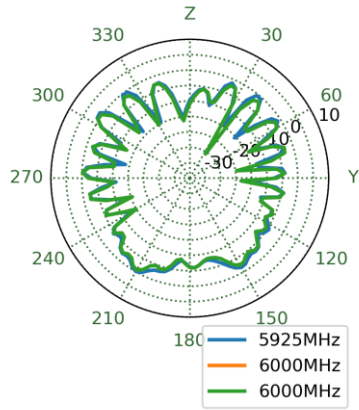
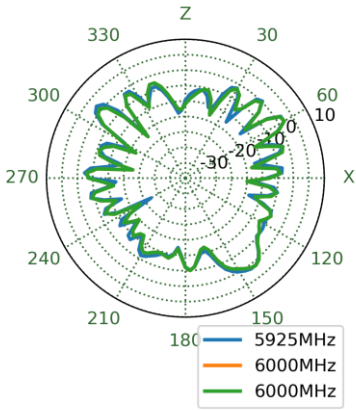

**4.15** On 15x9cm Ground - Patterns at 6600 MHz

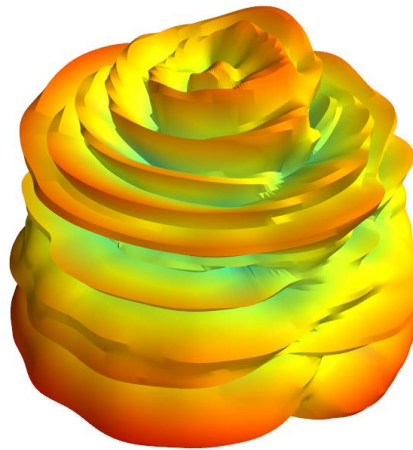

**XZ Plane                      YZ Plane                      XY Plane**

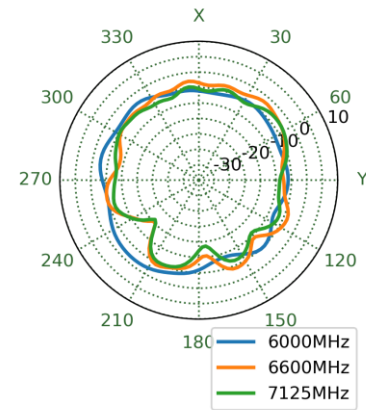
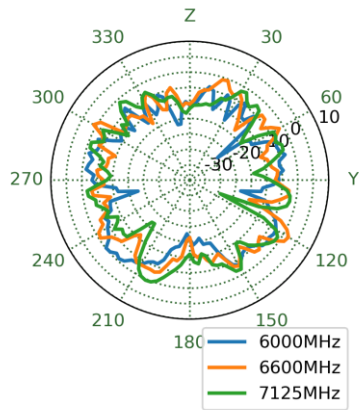
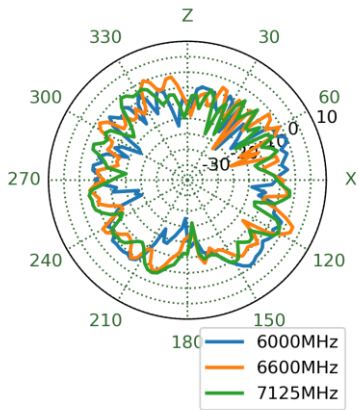

4.16 On 9x15cm Ground - Patterns at 824 MHz

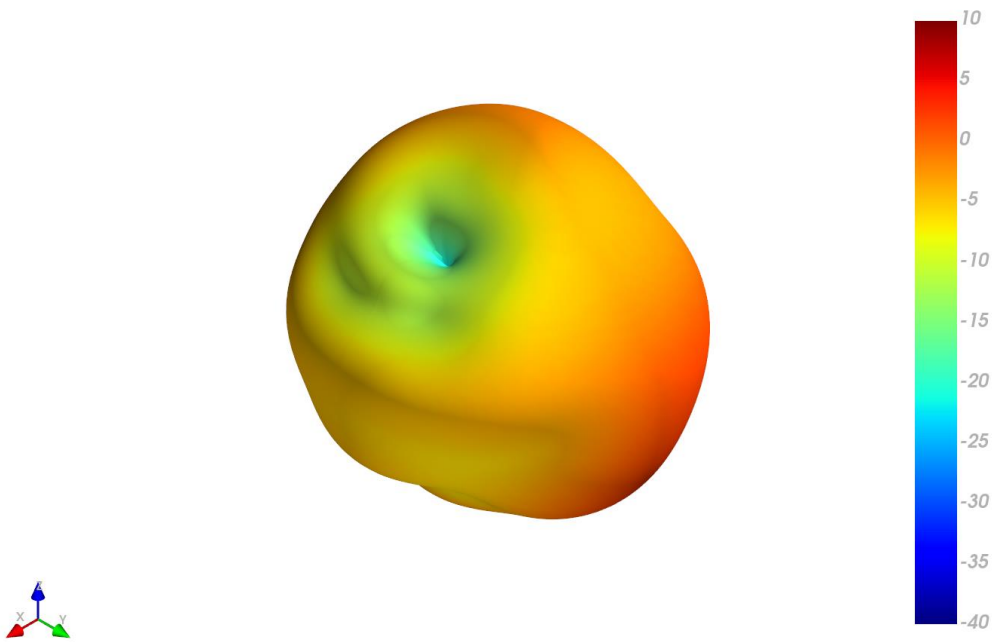

XZ Plane                      YZ Plane                      XY Plane

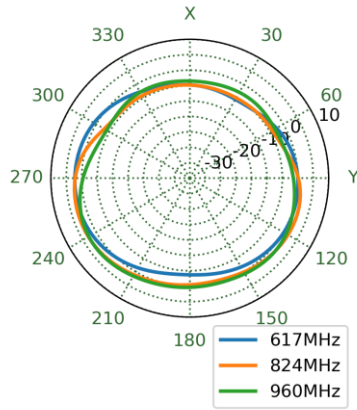
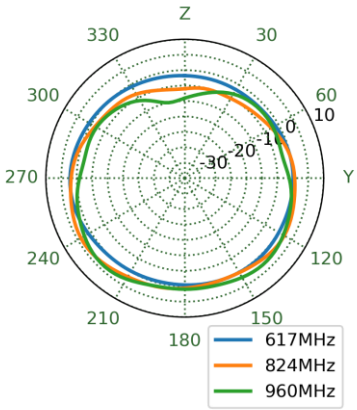
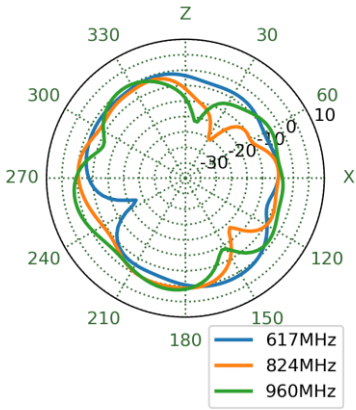

4.17 On 9x15cm Ground - Patterns at 2170 MHz

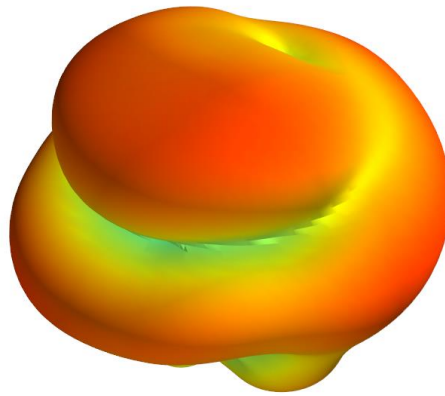

XZ Plane                      YZ Plane                      XY Plane

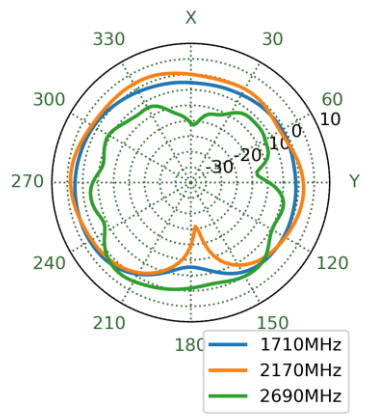
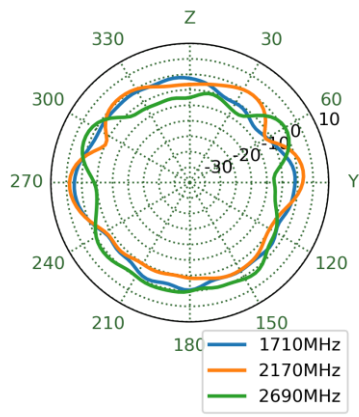
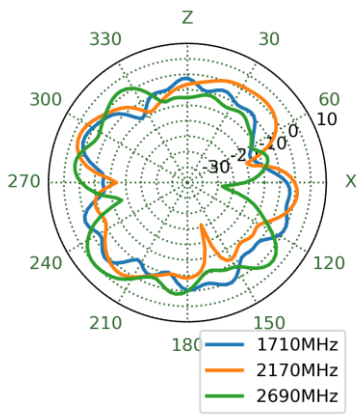



4.18 On 9x15cm Ground - Patterns at 3550 MHz

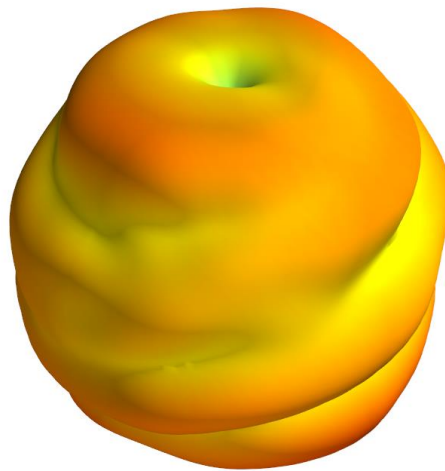

XZ Plane      YZ Plane      XY Plane

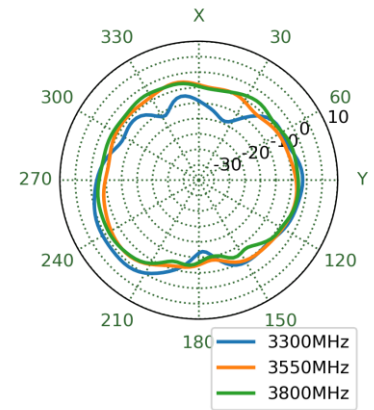
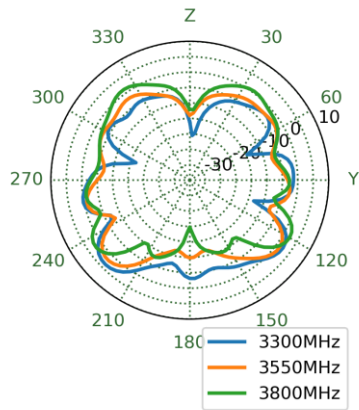
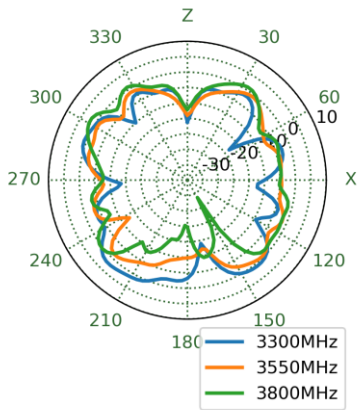

4.19 On 9x15cm Ground - Patterns at 4600 MHz

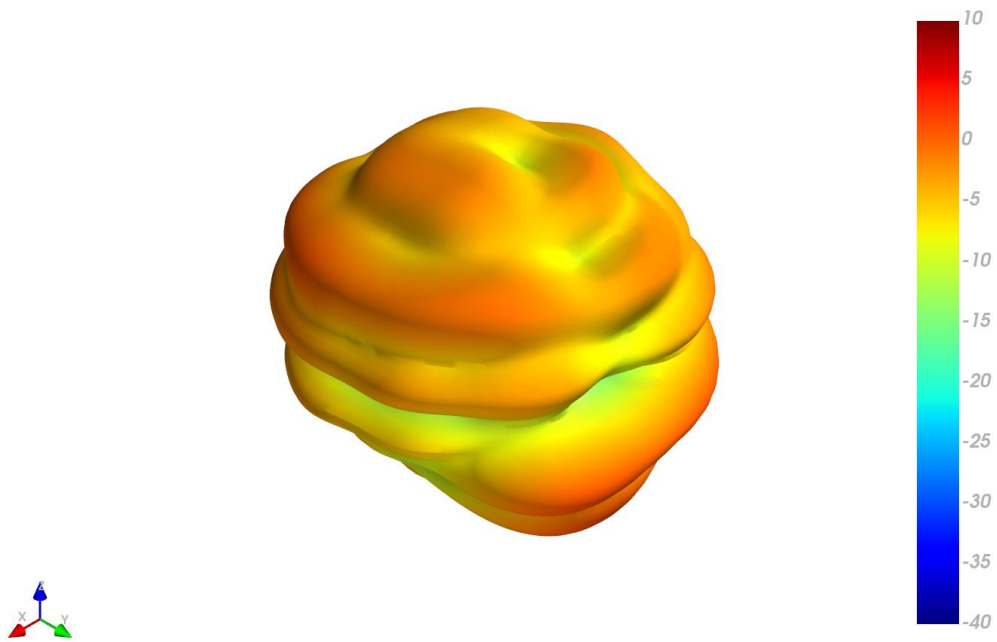

XZ Plane      YZ Plane      XY Plane

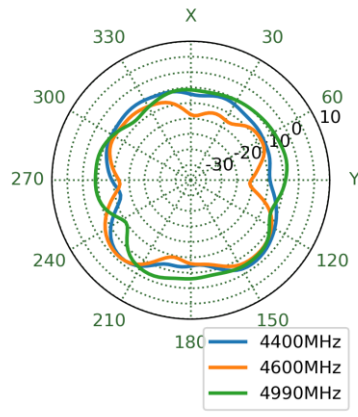
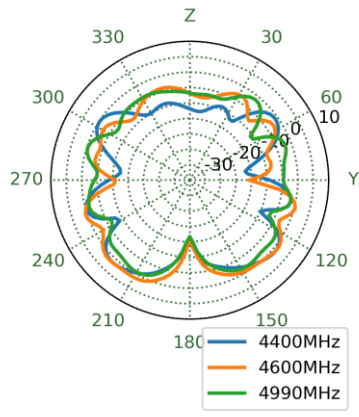
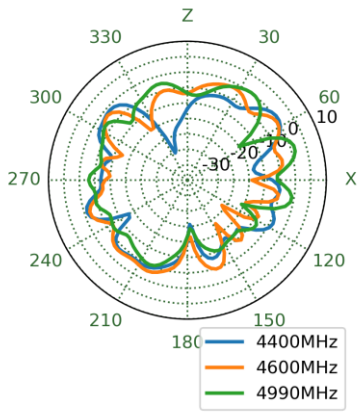

4.20 On 9x15cm Ground - Patterns at 5490 MHz

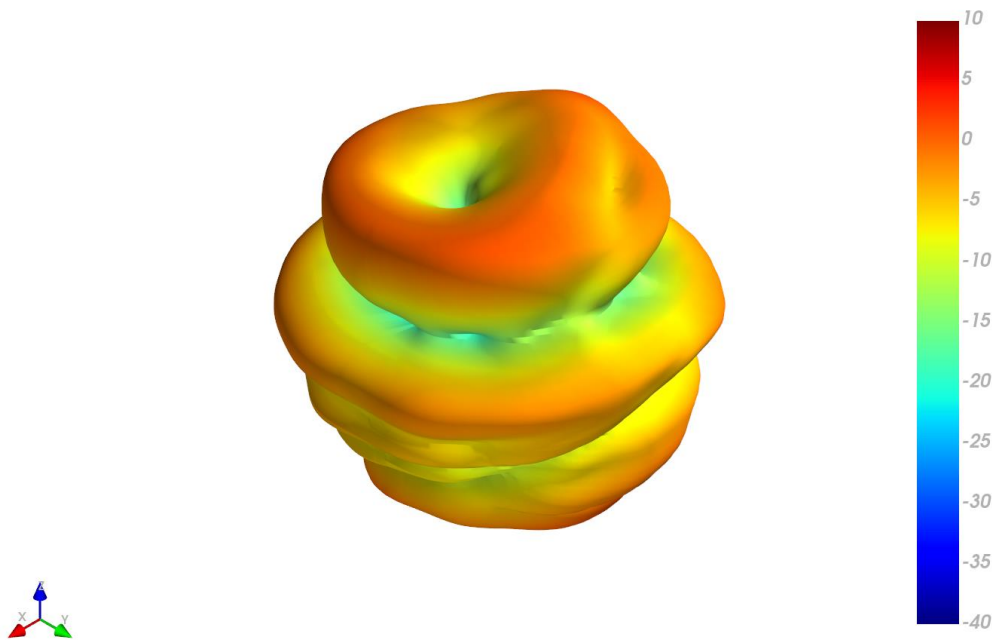

XZ Plane      YZ Plane      XY Plane

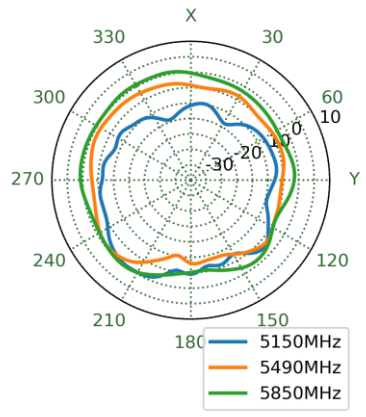
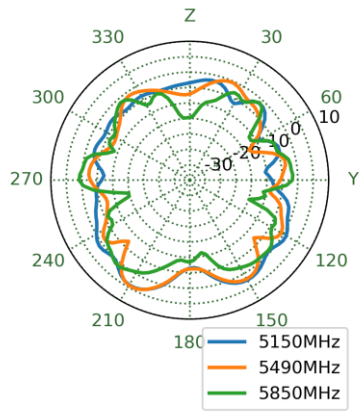
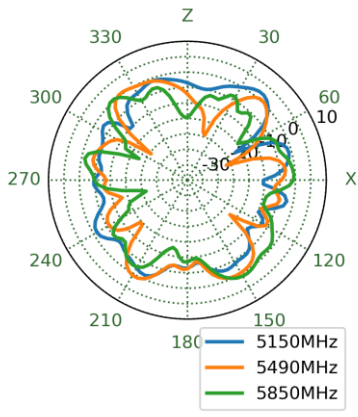

4.21 On 9x15cm Ground - Patterns at 6000 MHz

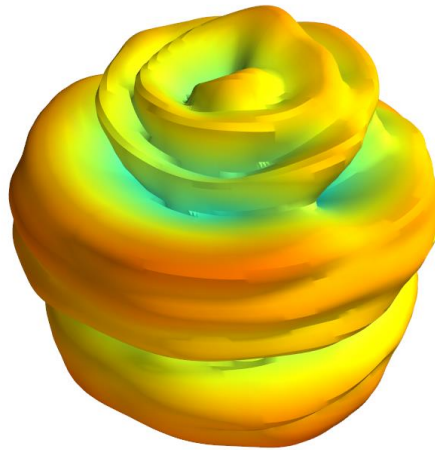

XZ Plane                      YZ Plane                      XY Plane

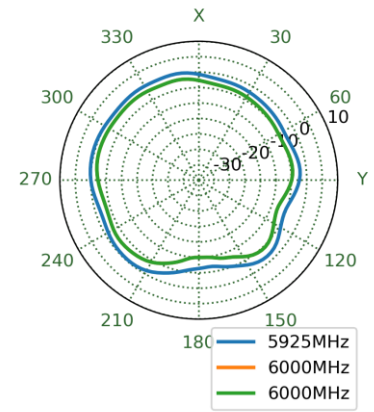
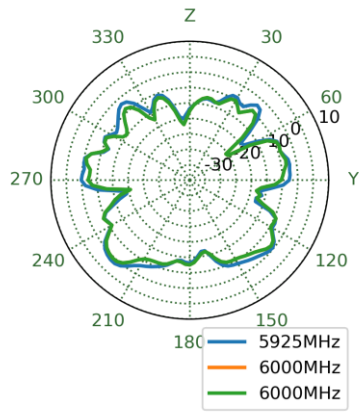
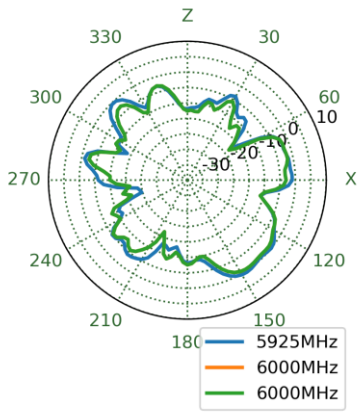

4.22 On 9x15cm Ground - Patterns at 6600 MHz

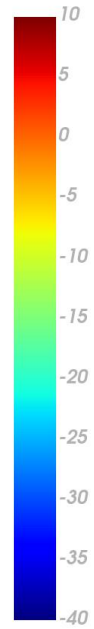
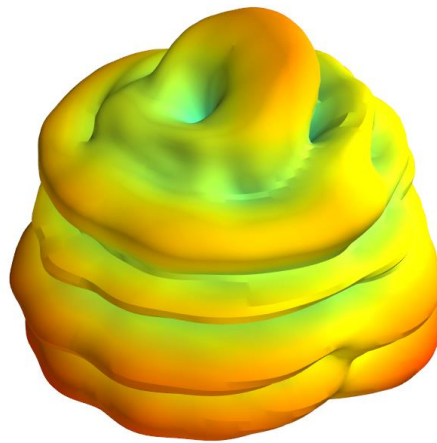

XZ Plane      YZ Plane      XY Plane

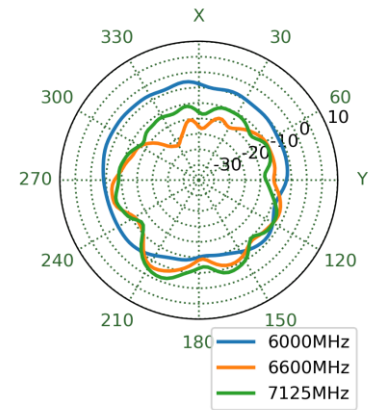
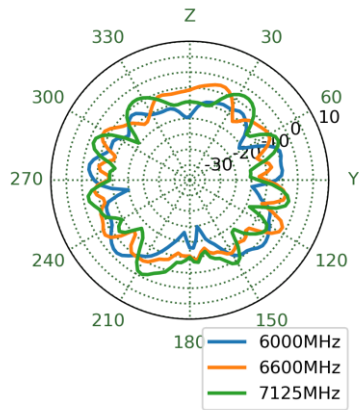
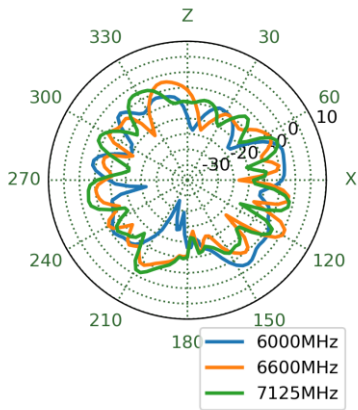

## 5. Mechanical Drawing

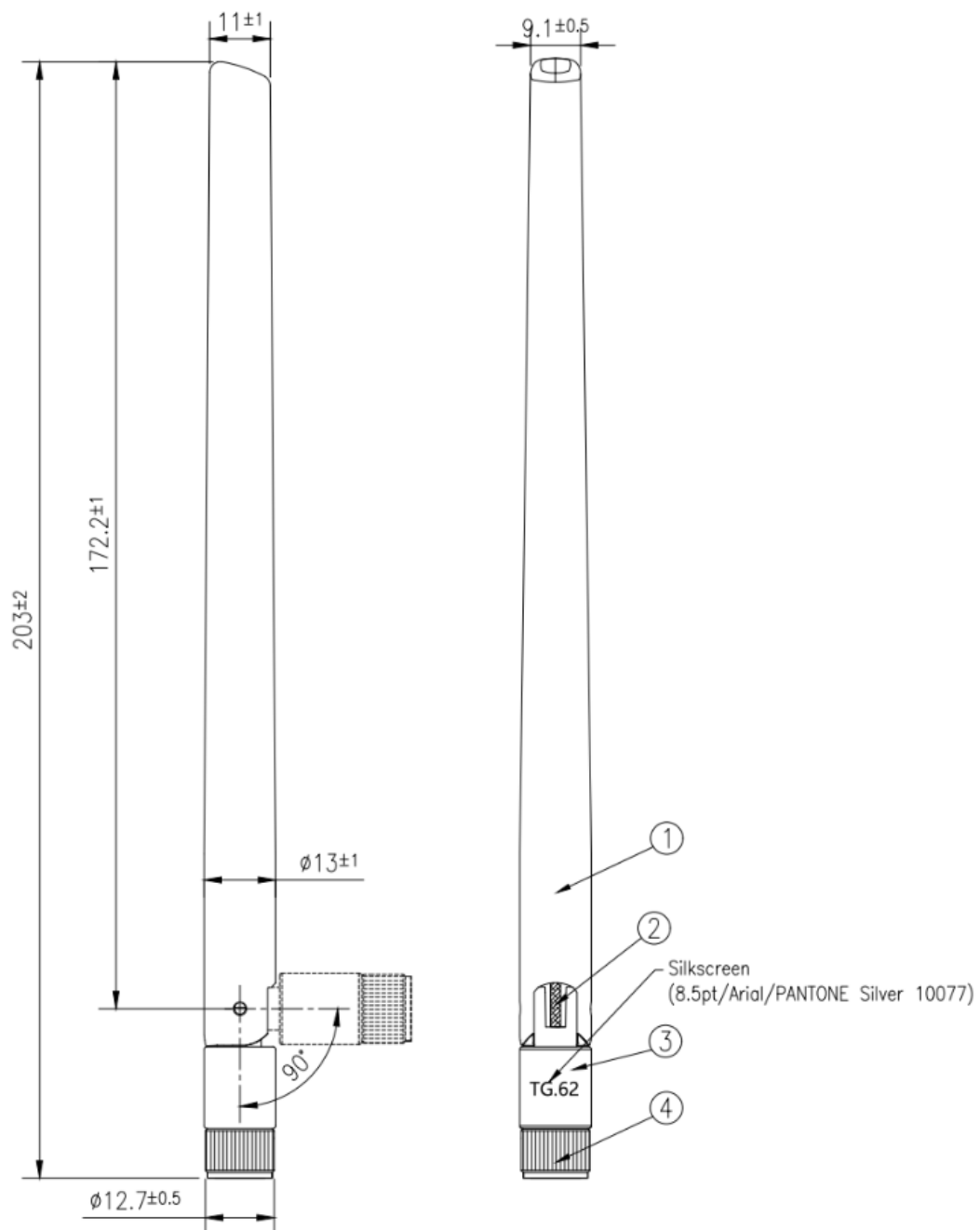

	Name	Material	Finish	QTY
1	Radome	PC+PBT	Black	1
2	RG178 coaxial cable	FEP	Brown	1
3	Lower Holder	PC+PBT	Black	1
4	SMA(M)	PC+PBT	Black	1

## 6. Packaging

TBD

Changelog for the datasheet

**SPE-23-8-274 – TG.62.A113**

<b>Revision: A (Original First Release)</b>	
Date:	2023-09-27
Notes:	Initial Release
Author:	Gary West

**Previous Revisions**





[www.taoglas.com](http://www.taoglas.com)

