



TAOGLAS®



Datasheet

Part No:
GW.51.5153W

Description:

White Wi-Fi 2.4/5.8/7.1GHz 5dBi Dipole Terminal Mount Antenna RP-SMA(M)
Hinged

Features:

2.4/5.8/7.1GHz Band Operation

Wi-Fi 6/7 Compatible

5dBi Gain

High Efficiency up to 80%

Hinged RP-SMA (M) Connector

Height: 198mm

Diameter: 13mm

RoHS & Reach Compliant

1. Introduction	3
2. Specifications	4
3. Antenna Characteristics	5
4. Radiation Patterns	7
5. Mechanical Drawing	14
6. Packaging	15
<hr/>	
Changelog	16

Taoglas makes no warranties based on the accuracy or completeness of the contents of this document and reserves the right to make changes to specifications and product descriptions at any time without notice. Taoglas reserves all rights to this document and the information contained herein. Reproduction, use or disclosure to third parties without express permission is strictly prohibited.



1. Introduction



The Taoglas GW.51 is a white full band Wi-Fi terminal mount dipole antenna. At just 198mm in height and 13mm in diameter, the robust TPEE enclosure can be mounted straight or at right angle to the device with its hinged RP-SMA(M) connector. It is ideal for applications such as Bluetooth, BLE, ZigBee, Wi-Fi 6 & 7 and Wireless LAN. The GW.51, designed for superior performance and reliability, has an omnidirectional radiation pattern and extremely high efficiency and gain on all Wi-Fi bands.

Typical applications include:

- Smart Home
- Gateways/Routers
- Connected Agriculture

The GW.51 has up to 5dBi Peak making it a cost-effective, high-performing choice for any indoor or outdoor application. Many module manufacturers specify peak gain limits for any antennas that are to be connected to that module. Those peak gain limits are based on free-space conditions. In practice, the peak gain of an antenna tested in free-space can degrade by at least 1 or 2dBi when installed.

So ideally you should go for a slightly higher peak gain antenna than mentioned on the module specification to compensate for this effect. This provides you with improved performance. Upon testing of any of our antennas with your device and appropriate layout, integration technique, or cable, we can work with you to make any of our antennas' perform below the peak gain limits.

Taoglas can then issue a specification and/or report for the selected antenna in your device that will clearly show it complying with the peak gain limits. You can be assured that you are meeting the regulatory requirements for that module whilst getting the best performance possible, without exceeding the peak gain limits.

For further information, or support to test and integrate this product please contact your regional Taoglas customer support team.

2. Specifications

Electrical		
Frequency (MHz)	2400~2500	4900~5850
Efficiency (%)		
Free space	63	61
30X30cm Ground plane	64	65
Average Gain (dB)		
Free space	-1.99	-2.14
30X30cm Ground plane	-1.94	-1.89
Peak Gain (dBi)		
Free space	5.23	5.54
30X30cm Ground plane	4.52	6.38
Impedance	50Ω	
Polarization	Linear	
Radiation Pattern	Omni	
Max. input power	1W	
Mechanical		
Height	198 ±3.3 mm	
Diameter	Ø13 mm	
Casing	TPEE	
Connector	RP-SMA(M)	
Weight	22.5 g	
Environmental		
Temperature Range	-40°C to 85°C	
Humidity	Non-condensing 65°C 95% RH	

3. Antenna Characteristics

3.1 Return Loss

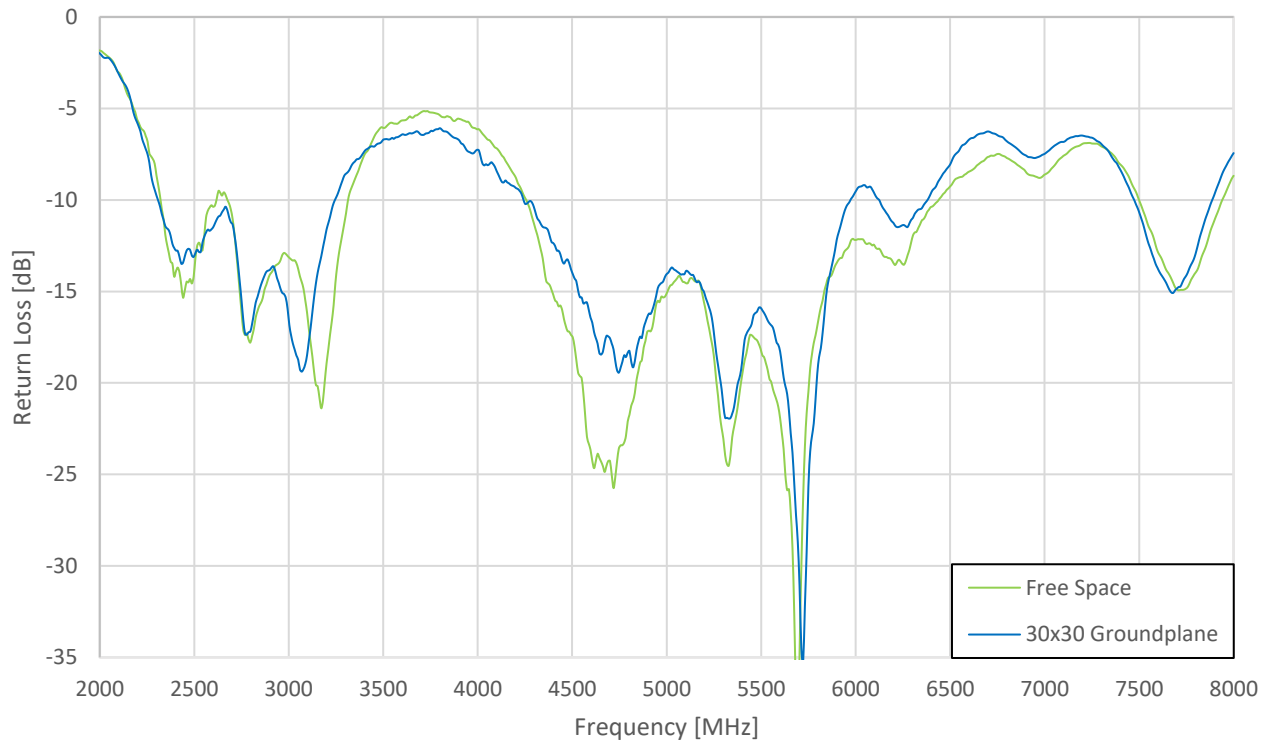

3.2 Efficiency

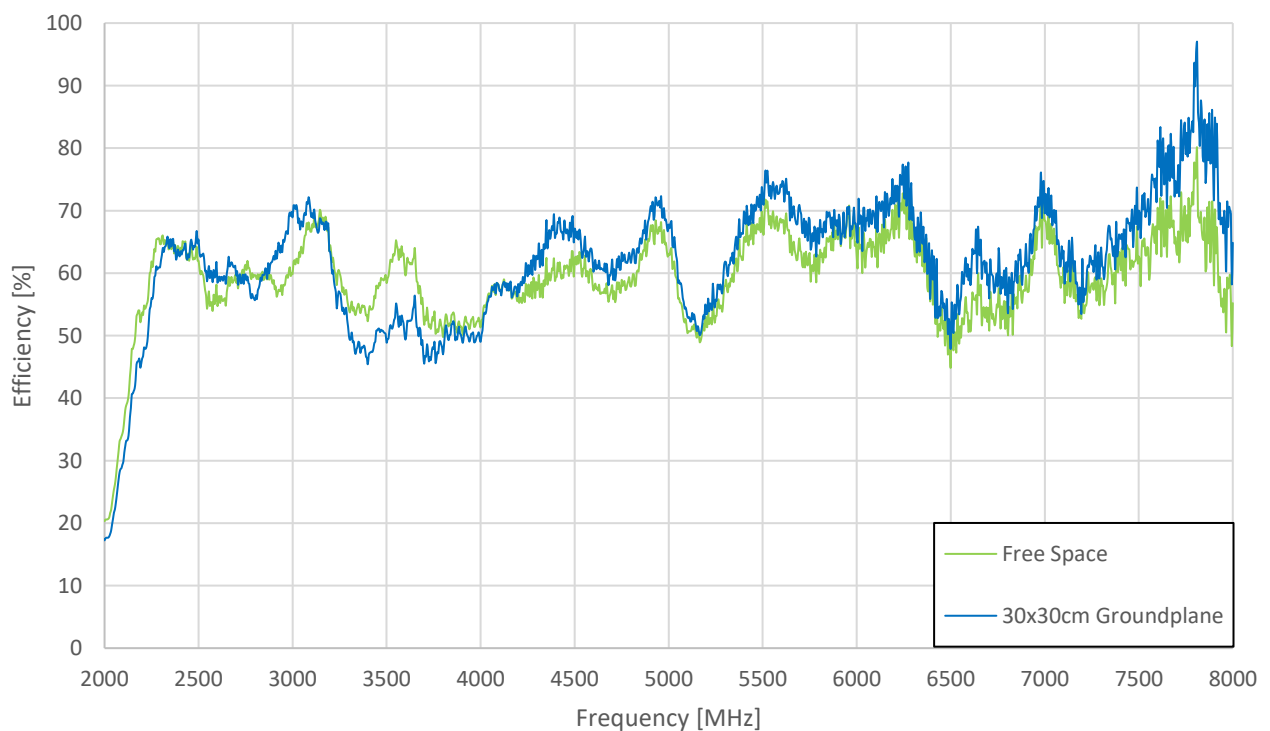

3.3 Average Gain

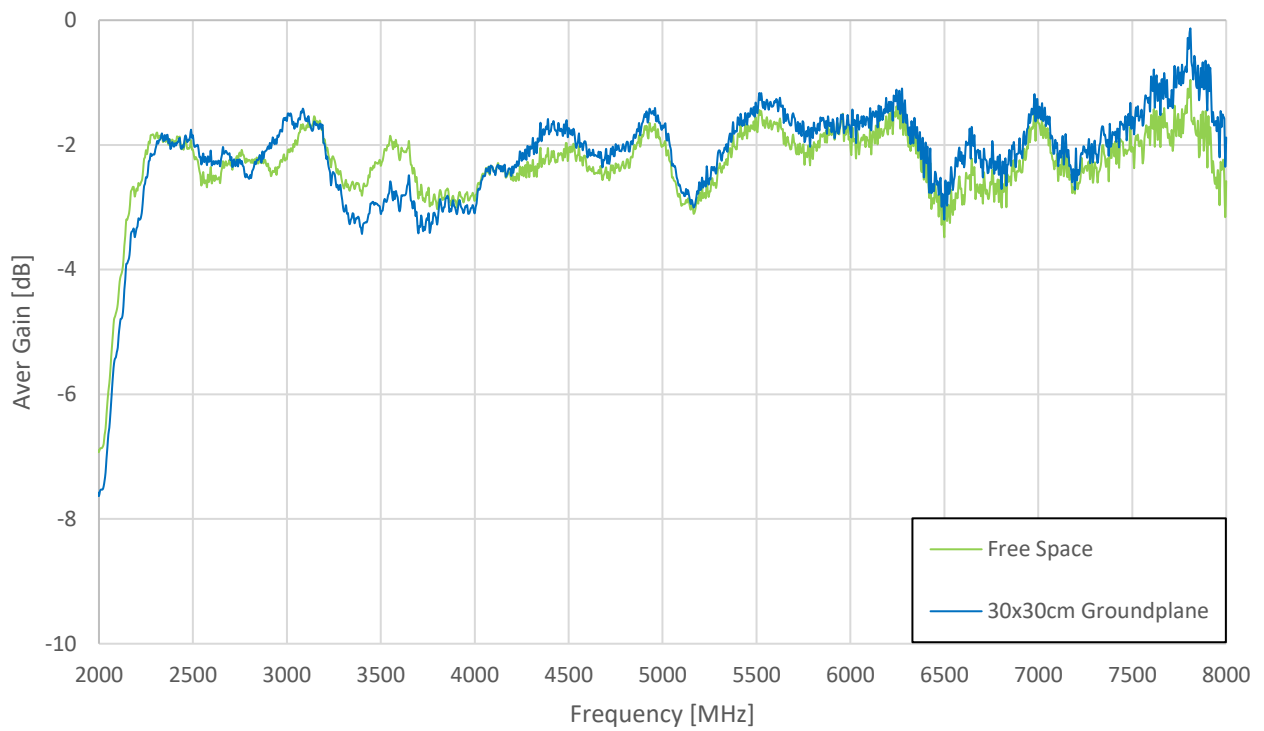

3.4 Peak Gain

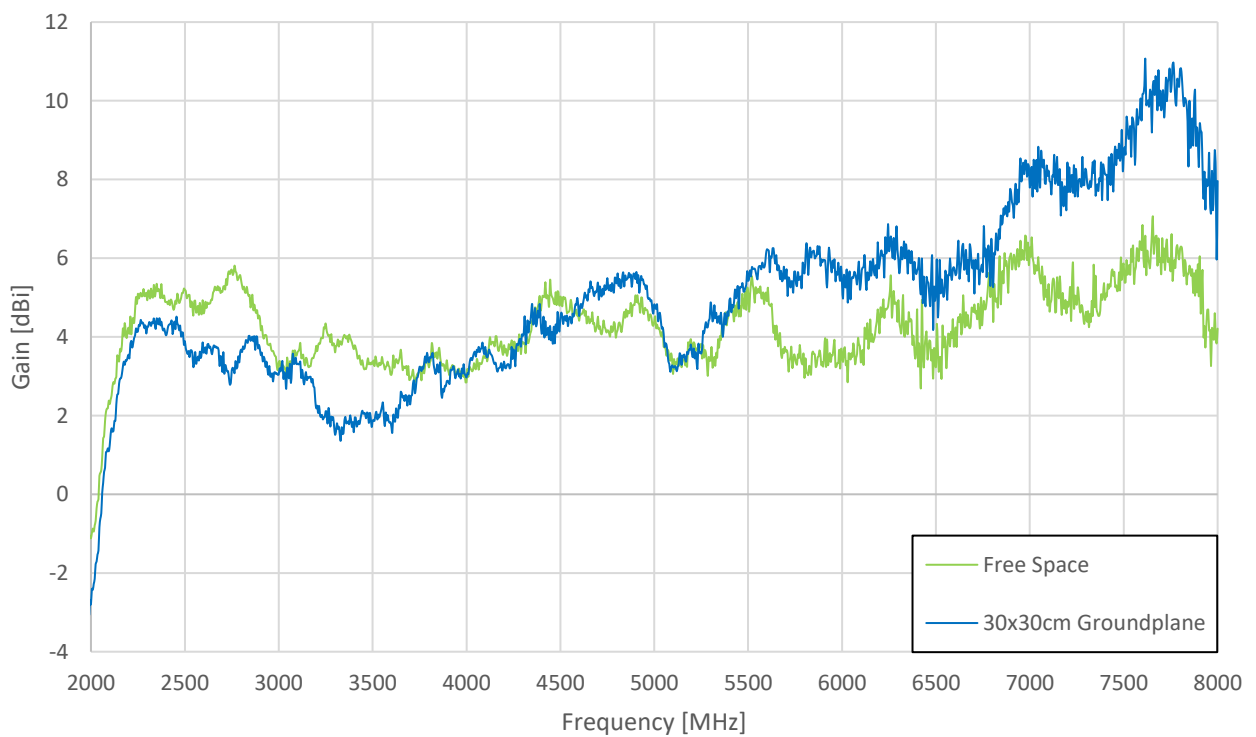

4. Radiation Patterns

4.1 Test Setup

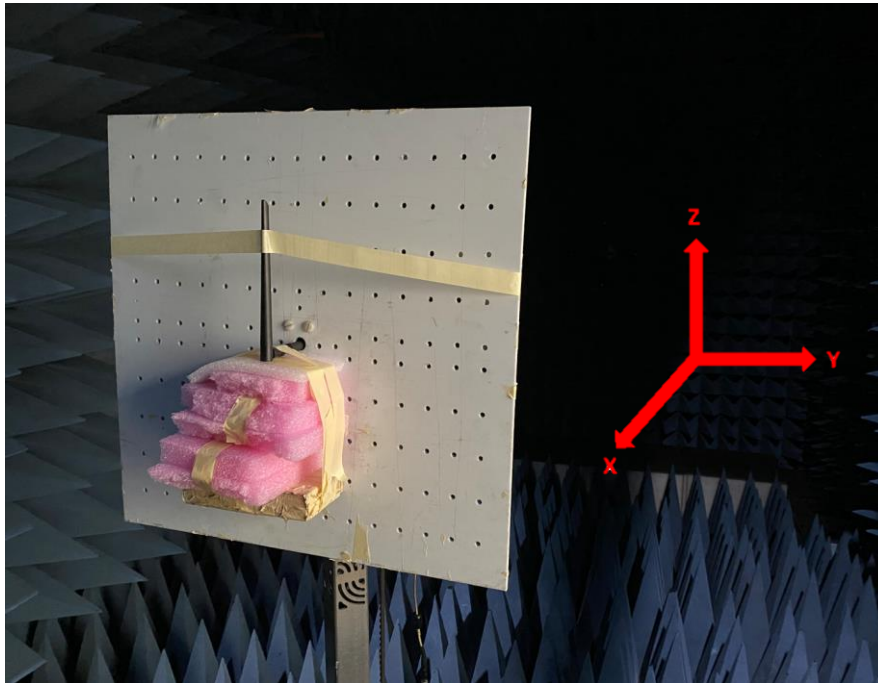

Free space

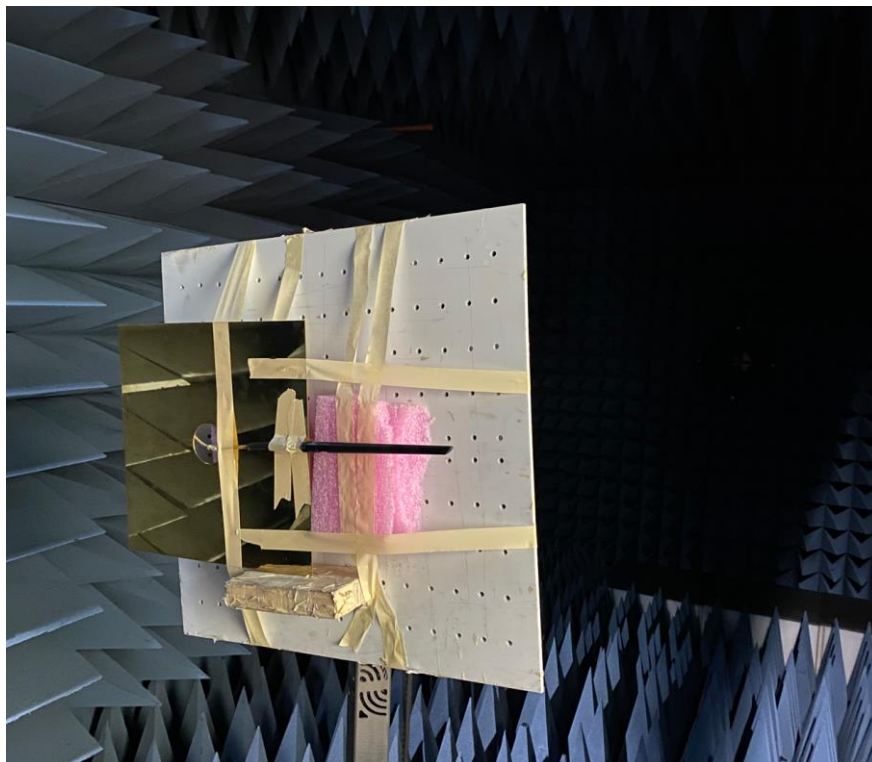

30 x30cm Ground plane

4.2 2400MHz 3D and 2D Radiation Patterns – Free space

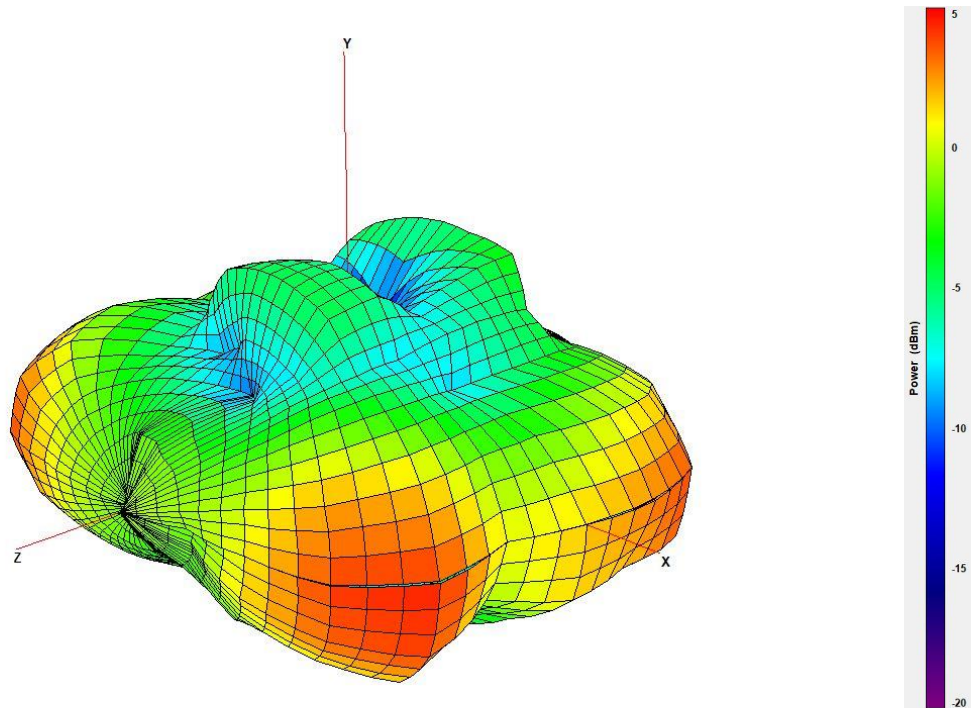

XY Plane XZ Plane YZ Plane

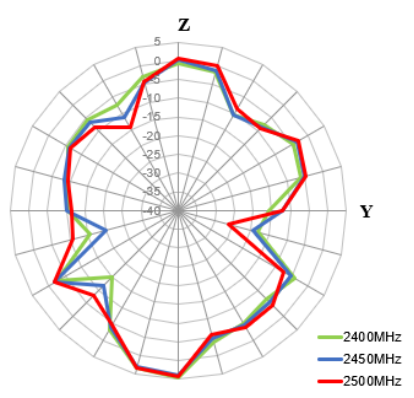
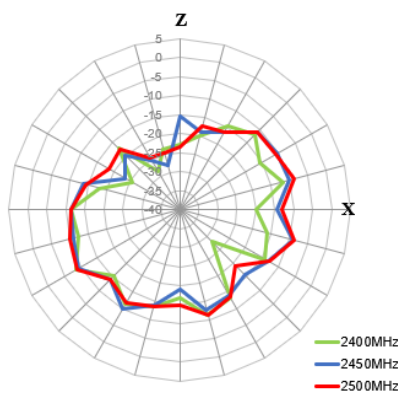
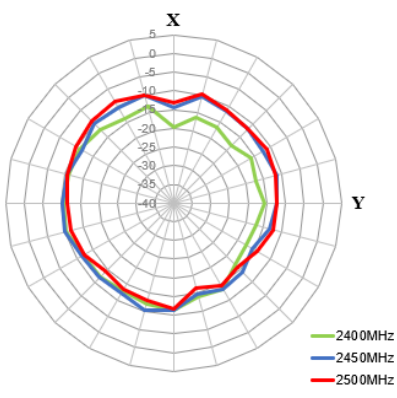

4.3 2400MHz 3D and 2D Radiation Patterns – 30x30cm Ground plane

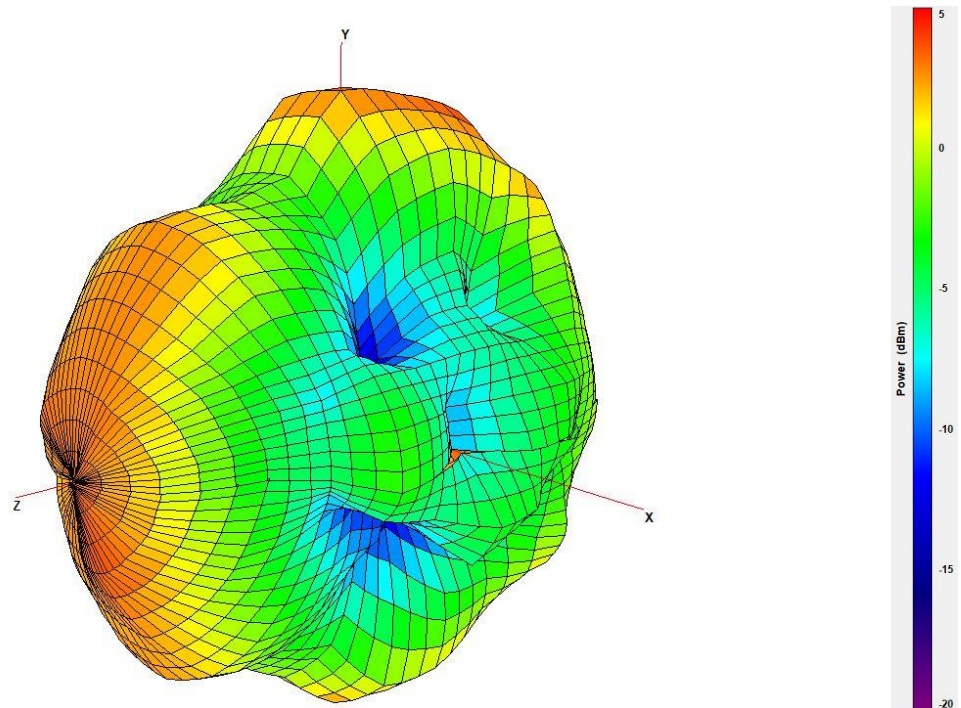

XY Plane

XZ Plane

YZ Plane

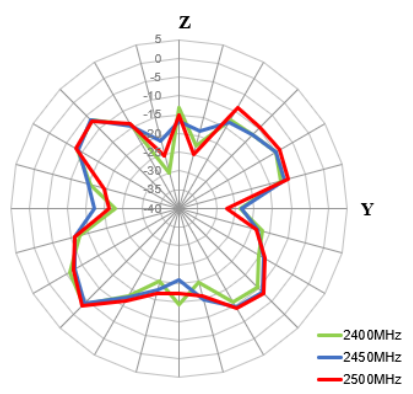
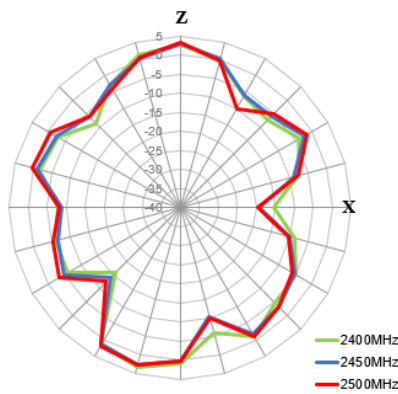
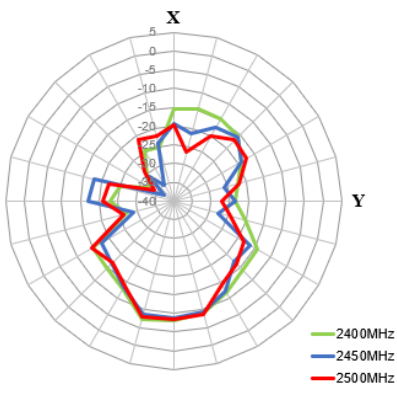

4.4 5800MHz 3D and 2D Radiation Patterns – Free space

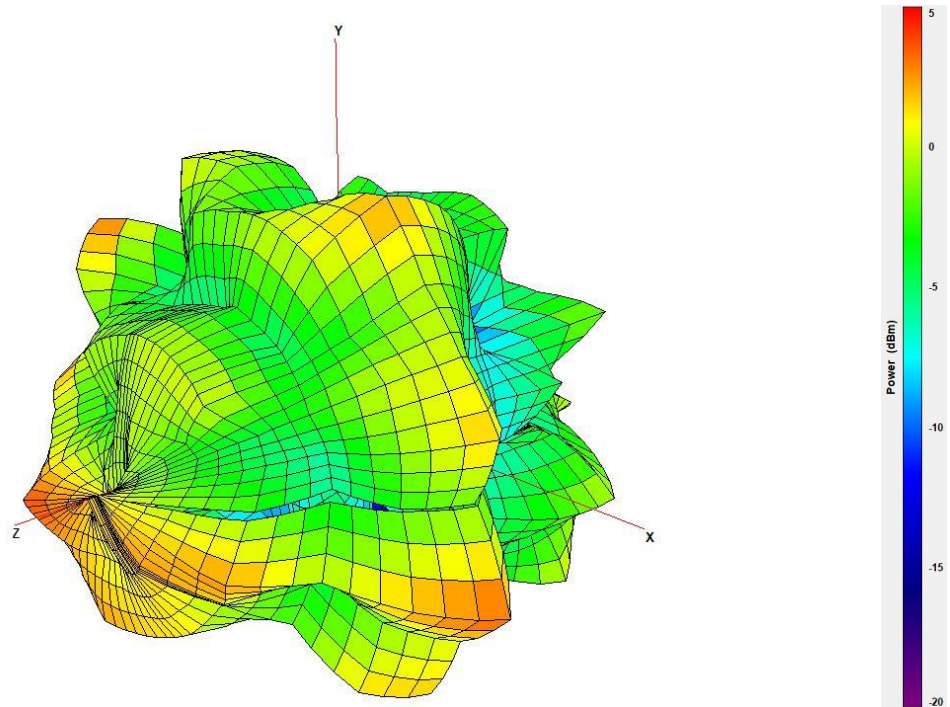

XY Plane XZ Plane YZ Plane

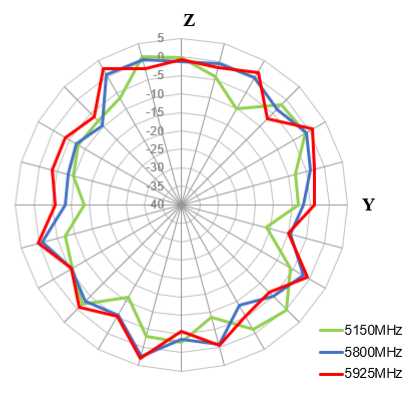
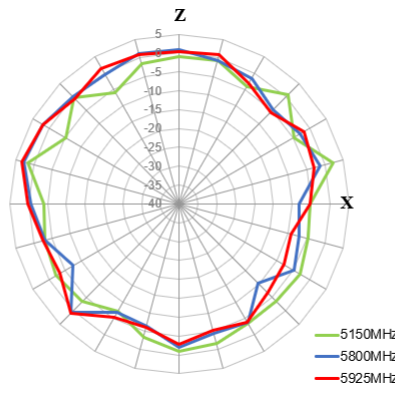
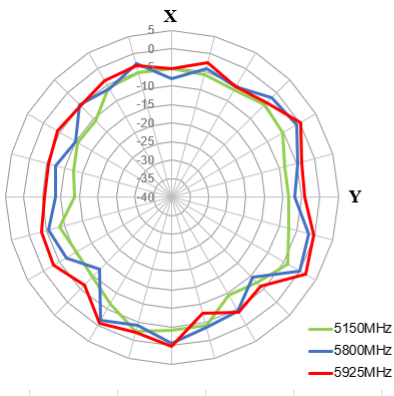

4.5 5800MHz 3D and 2D Radiation Patterns – 30x30cm Ground plane

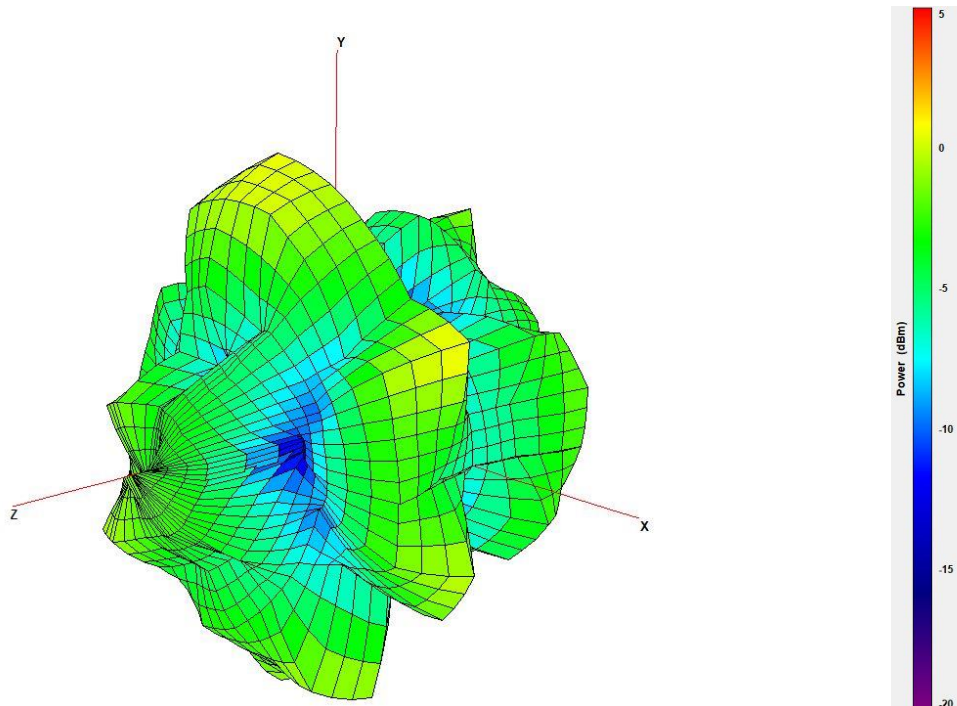

XY Plane XZ Plane YZ Plane

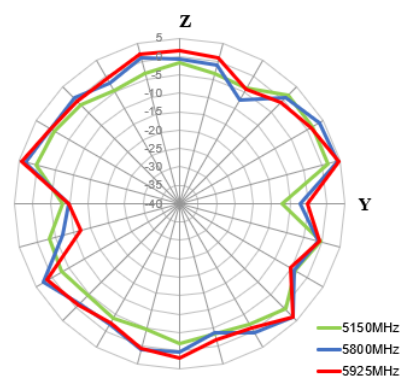
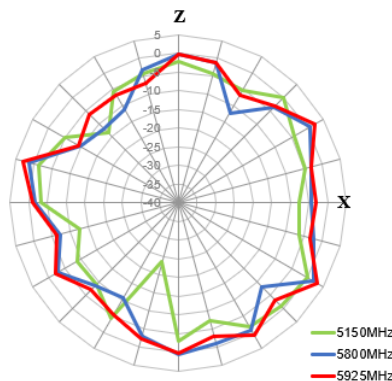
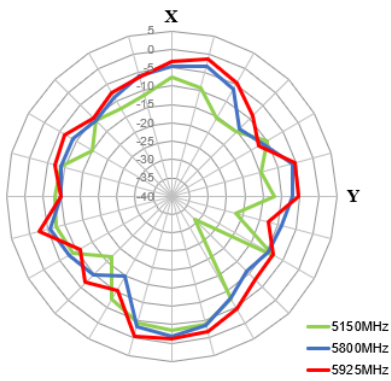

4.6 6500MHz 3D and 2D Radiation Patterns – Free space

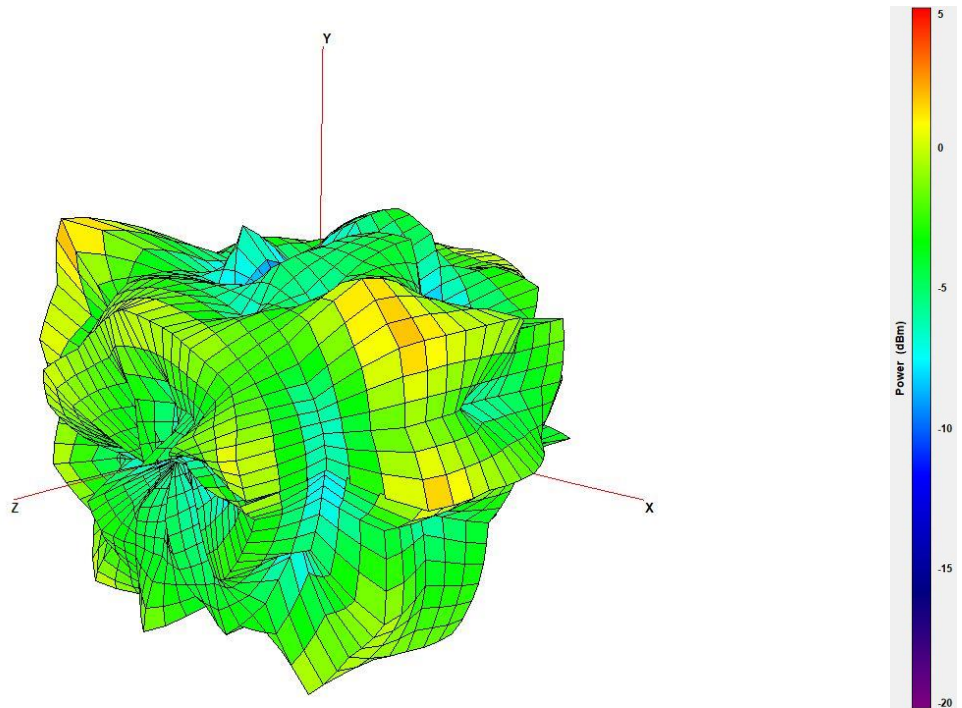

XY Plane XZ Plane YZ Plane

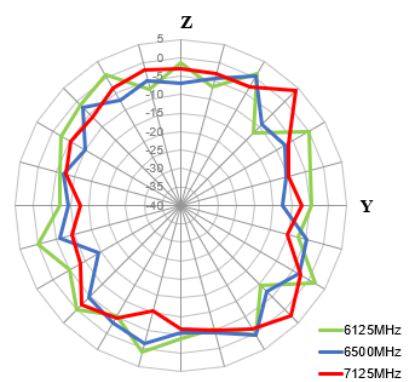
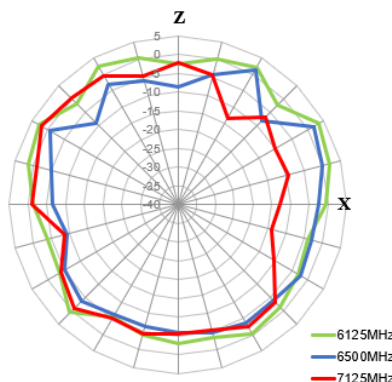
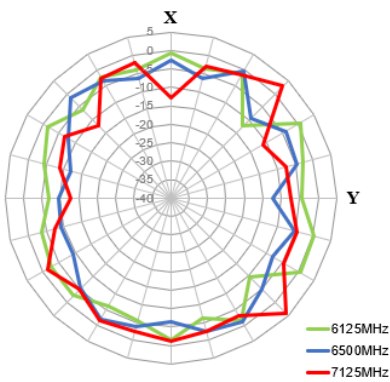

4.7 6500MHz 3D and 2D Radiation Patterns – 30x30cm Ground plane

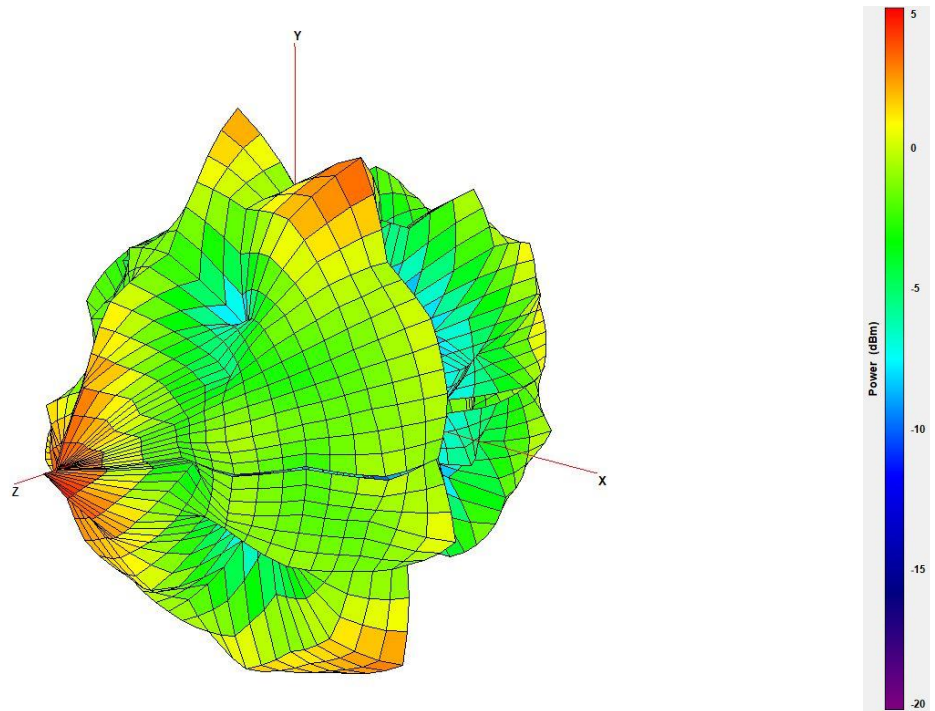

XY Plane XZ Plane YZ Plane

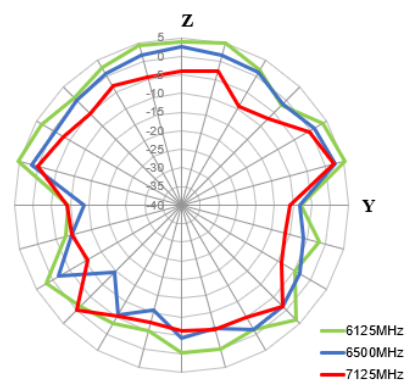
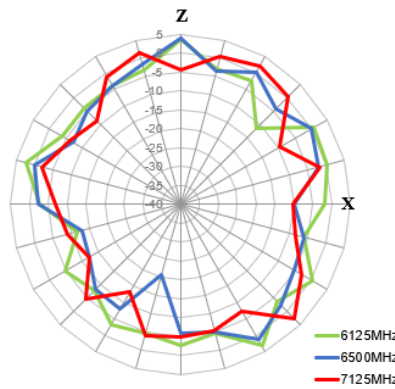
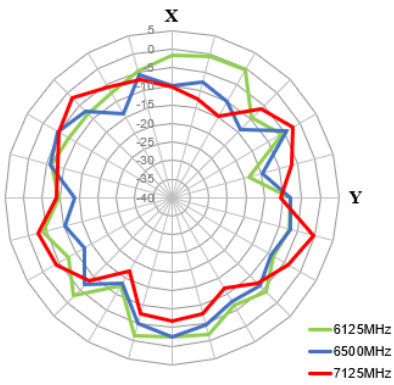

5. Mechanical Drawing (Units: mm)

ISO NO.: EDW-22-8-0841
 STATE: Release
 NOTES:

REV.	DESCRIPTION	ENG.	APPROVED	DATE
001	Initial Design	Ruby	Aaron	2022/07/26

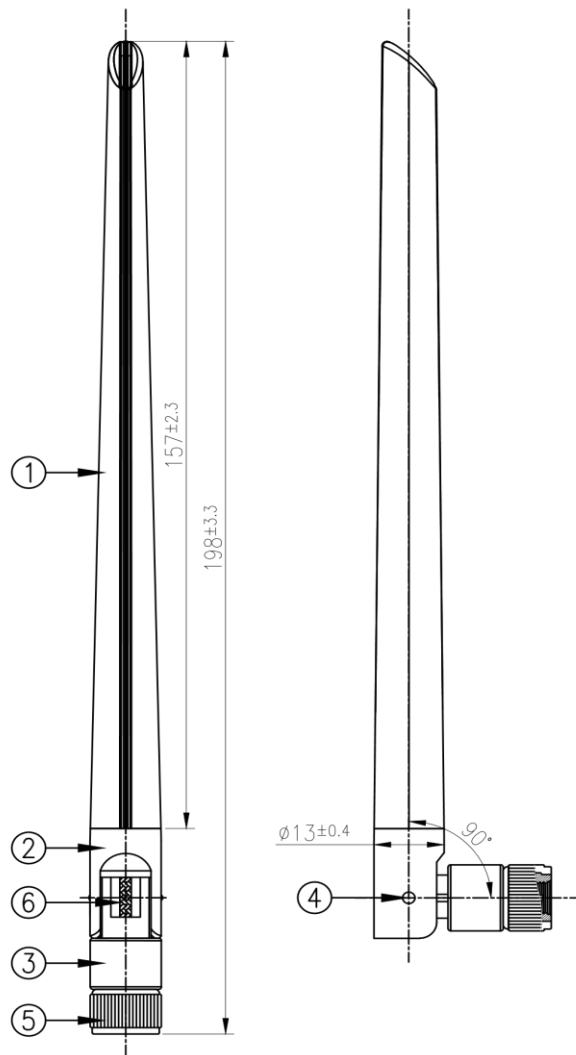

	Name	Material	Finish	QTY
1	Antenna Cap	TPEE	White	1
2	Upper Base	PBT+PC	White	1
3	Bottom Base	PBT+PC	White	1
4	Rivet	PBT+PC	White	2
5	RP-SMA(M)	POM	White	1
6	RG178 Coaxial Cable	FEP	Brown	1

APPROVED BY: Aaron	TW Design Centre <small>This drawing is Taoglas Confidential Information and its inherent design concepts are property of Taoglas. This is not to be copied or shared with third parties without the prior written consent of Taoglas.</small>
CHECK BY: Aaron	
DRAWN BY: Ruby	
DATE: 2022/07/26	TITLE : 5dBi 2.4/5.8GHz Dipole Antenna RP-SMA(M) Hinged White Housing
UNLESS OTHERWISE SPECIFIED TOLERANCES ON: XX±0.5 X±0.3 J±0.2 J0K±0.1 J00K±0.05	PART NO. : GW.51.5153W
THIRD ANGLE PROJECTION	UNIT: mm SCALE: 1:1.25 PAGES: 1/1 REV. D01

6. Packaging

1pc GW.51.5153W per PE Bag
 Bag Dimension: 245*30mm
 Weight: 22.5g

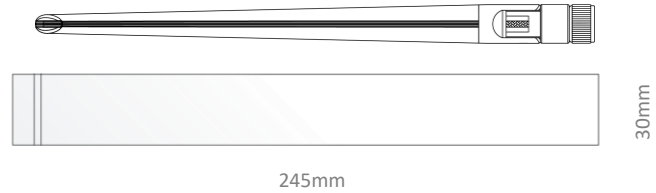

40pcs GW.51.5153W per Large PE Bag
 Bag Dimensions: 320*205mm
 Weight: 0.9Kg

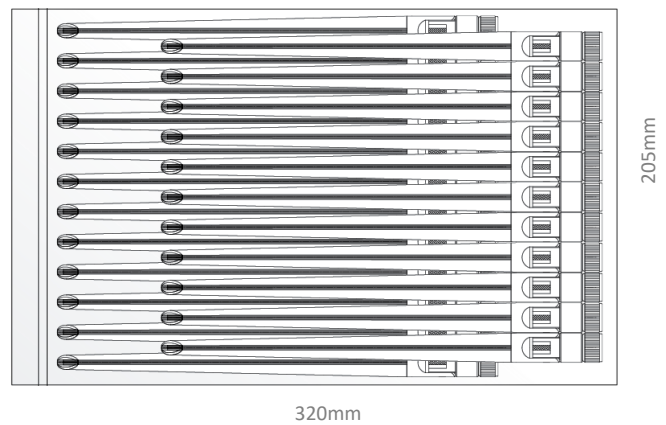

400pcs GW.51.5153W per Carton
 Dimensions: 320*250*230mm
 Weight: 10Kg

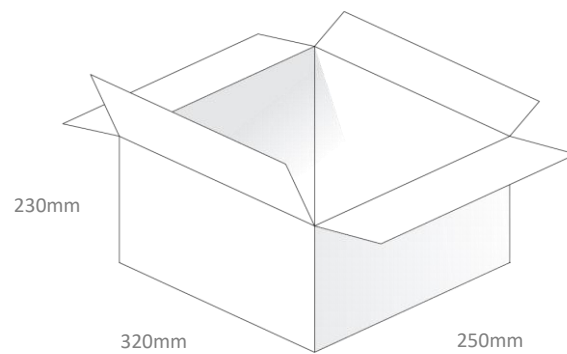

Pallet Dimensions:
 1200*1000*1350mm
 60 Cartons Per Pallet
 12 Cartons Per Layer, 5 Layers

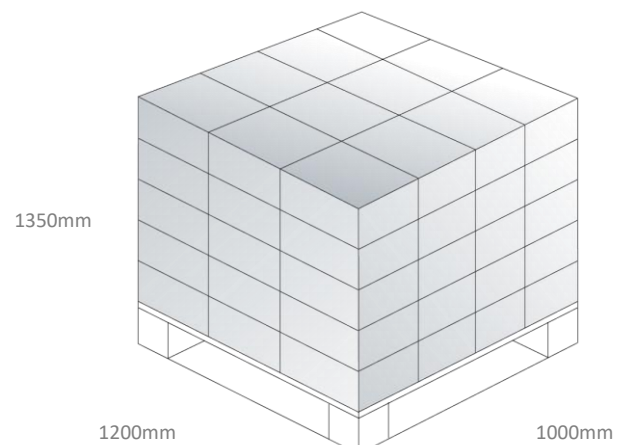

Changelog for the datasheet

SPE-19-8-087 – GW.51.5153W

Revision: B (Current Version)

Date:	2022-07-29
Notes:	Updated data to include Wi-Fi 6.
Author:	Gary West

Previous Revisions

Revision: A (Original First Release)

Date:	2022-07-25
Notes:	
Author:	Jack Conroy



TAOGLAS®

www.taoglas.com

