

Part Number : **71113AS**

Type	Size	Rating	Description
Incandescent	T5	12V 1.28W	Lamp in socket

Dimensions(mm):

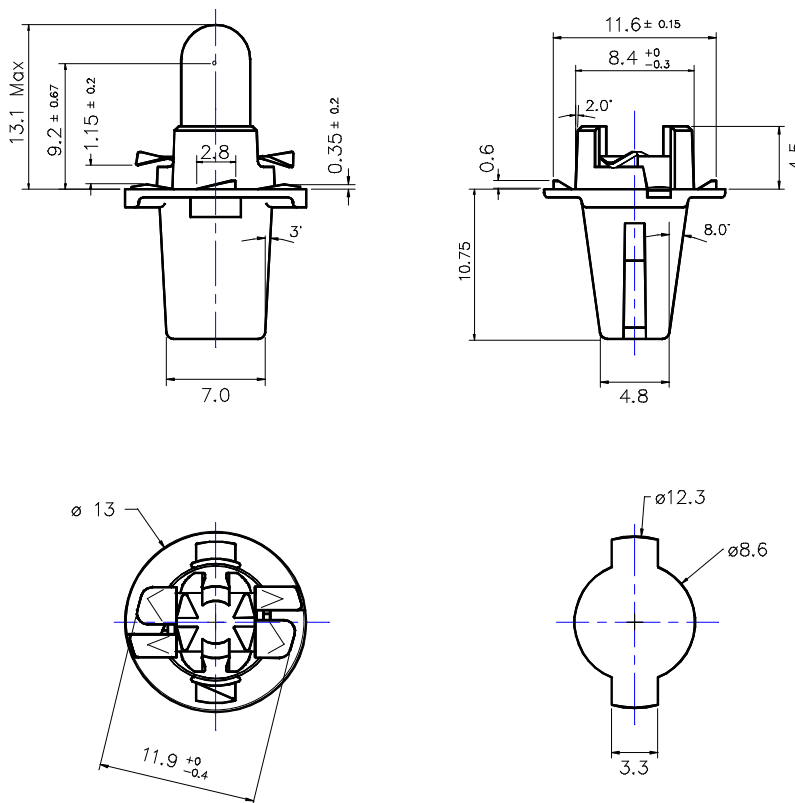

TEST VOLTS	CURRENT (mA)			LIGHT OUTPUT (Lm)			LIFE Hours
	Min.	Nom.	Max.	Min.	Nom.	Max.	
13.5	86	95	104	6.0	7.0	8.0	6200(B _{63.2})

Notes:

- 1 Grey coloured socket body
- 2 RoHS and REACH SVHC compliant

Issue # 1 : 5Aug11