

Operating Instructions

Cerabar PMP11, PMP21, PMP23

Process pressure measurement
Pressure transducer for safe measurement and
monitoring of absolute and gauge pressure

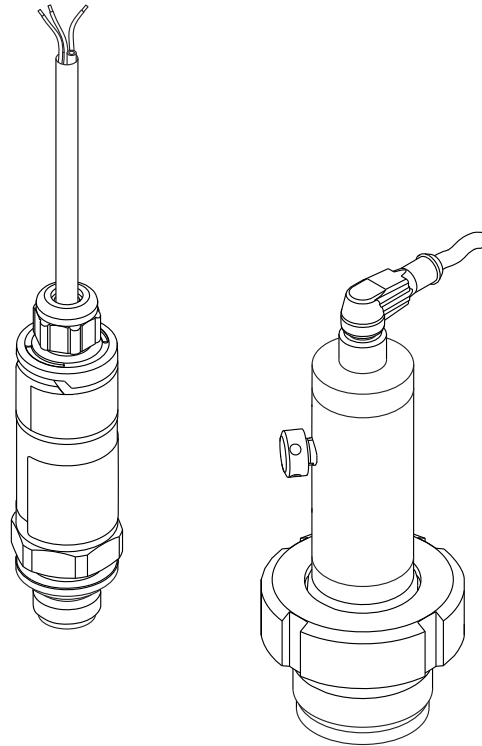

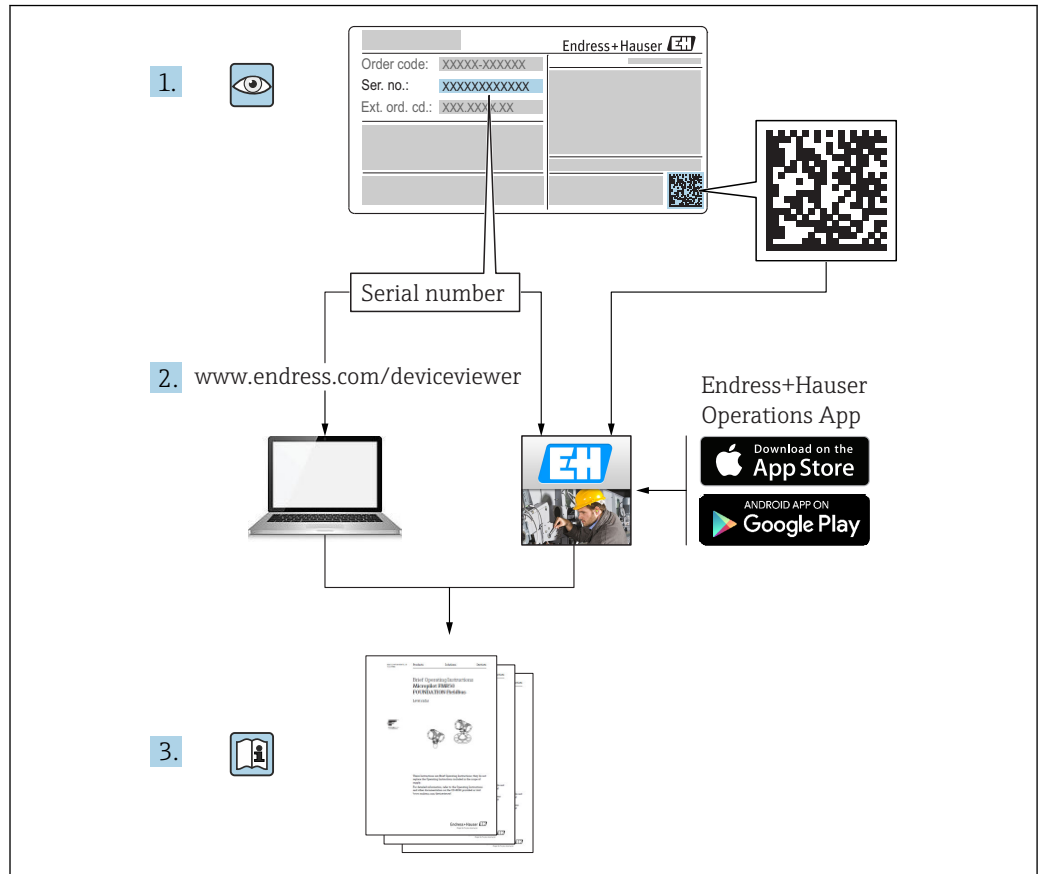

A0023555

- Make sure the document is stored in a safe place such that it is always available when working on or with the device.
- To avoid danger to individuals or the facility, read the "Basic safety instructions" section carefully, as well as all other safety instructions in the document that are specific to working procedures.
- The manufacturer reserves the right to modify technical data without prior notice. Your Endress+Hauser distributor will supply you with current information and updates to these Instructions.

Table of contents

1	Document information	4	10	Repair	26
1.1	Document function	4	10.1	General notes	26
1.2	Symbols used	4	10.2	Return	26
1.3	Documentation	5	11	Accessories	27
1.4	Terms and abbreviations	7	11.1	Weld-in adapter	27
1.5	Turn down calculation	8	11.2	Process adapter M24	27
2	Basic safety instructions	9	11.3	Plug-on display PHX20	28
2.1	Requirements concerning the staff	9	11.4	M12 plug connectors	28
2.2	Designated use	9	12	Technical data	29
2.3	Workplace safety	10	12.1	Input	29
2.4	Operational safety	10	12.2	Output	31
2.5	Product safety	10	12.3	Performance characteristics of metallic process isolating diaphragm	33
3	Product description	11	12.4	Environment	35
3.1	Product design	11	12.5	Process	37
3.2	Function	11	Index	38	
4	Incoming acceptance and product identification	12			
4.1	Incoming acceptance	12			
4.2	Product identification	13			
4.3	Storage and transport	13			
5	Installation	15			
5.1	Mounting dimensions	15			
5.2	Installation conditions	15			
5.3	Influence of the installation position	15			
5.4	Mounting location	16			
5.5	Mounting the profiled seal for the universal process adapter	17			
5.6	Post-installation check	17			
6	Electrical connection	18			
6.1	Connecting the measuring unit	18			
6.2	Connection conditions	19			
6.3	Connection data	19			
6.4	Post-connection check	20			
7	Operation options	21			
7.1	Plug-on display PHX20 (optional)	21			
8	Diagnostics and troubleshooting ...	24			
8.1	Troubleshooting	24			
8.2	Response of output to errors	24			
8.3	Disposal	24			
9	Maintenance	24			
9.1	Exterior cleaning	25			





1 Document information

1.1 Document function



These Operating Instructions contain all the information that is required in various phases of the life cycle of the device: from product identification, incoming acceptance and storage, to mounting, connection, operation and commissioning through to troubleshooting, maintenance and disposal.

1.2 Symbols used

1.2.1 Safety symbols

Symbol	Meaning
	DANGER! This symbol alerts you to a dangerous situation. Failure to avoid this situation will result in serious or fatal injury.
	WARNING! This symbol alerts you to a dangerous situation. Failure to avoid this situation can result in serious or fatal injury.
	CAUTION! This symbol alerts you to a dangerous situation. Failure to avoid this situation can result in minor or medium injury.
	NOTE! This symbol contains information on procedures and other facts which do not result in personal injury.



1.2.2 Electrical symbols







Symbol	Meaning	Symbol	Meaning
	Protective ground connection A terminal which must be connected to ground prior to establishing any other connections.		Ground connection A grounded terminal which, as far as the operator is concerned, is grounded via a grounding system.

1.2.3 Tool symbols

Symbol	Meaning
 A0011222	Open-ended wrench

1.2.4 Symbols for certain types of information

Symbol	Meaning
	Permitted Procedures, processes or actions that are permitted.
	Forbidden Procedures, processes or actions that are forbidden.
	Tip Indicates additional information.

Symbol	Meaning
	Reference to documentation
	Reference to page
	Reference to graphic
	Series of steps
	Result of a step
	Visual inspection

1.2.5 Symbols in graphics

Symbol	Meaning
1, 2, 3 ...	Item numbers
	Series of steps
A, B, C, ...	Views

1.3 Documentation

 The document types listed are available:
 In the Download Area of the Endress+Hauser Internet site: www.endress.com → Download

1.3.1 Technical Information (TI): planning aid for your device

PMP11: TI01133P

PMP21: TI01133P

PMP23: TI01203P

The document contains all the technical data on the device and provides an overview of the accessories and other products that can be ordered for the device.

1.3.2 Brief Operating Instructions (KA): getting the 1st measured value quickly

KA01164P:

The Brief Operating Instructions contain all the essential information from incoming acceptance to initial commissioning.

1.3.3 Safety Instructions (XA)

Safety Instructions (XA) are supplied with the device depending on the approval. These instructions are an integral part of the Operating Instructions.

Device	Directive	Documentation	Option ¹⁾
PMP21 PMP23	ATEX II 1/2G Ex ia IIC T4 Ga/Gb	XA01271P	BA
PMP21	ATEX II 3G Ex ec IIC T4 Gc	XA01533P	BC
PMP21 PMP23	FM IS Cl. I, Div.1 Gr. A-D T4	XA01321P	FA

Device	Directive	Documentation	Option ¹⁾
PMP21 PMP23	CSA C/US IS Cl. I Div. 1 Gr. A-D	XA01322P	CB
PMP21 PMP23	EAC Ex ia IIC T4 Ga/Gb	XA01540P	GA
PMP21 PMP23	IEC Ex ia IIC T4 Ga/Gb	XA01271P	IA
PMP21 PMP23	NEPSI Ex ia IIC T4	XA01363P	NA
PMP21 PMP23	TIIS Ex ia IIC T4	In preparation	TA

1) Product Configurator, order code for "Approval"

 The nameplate provides information on the Safety Instructions (XA) that are relevant for the device.

1.4 Terms and abbreviations

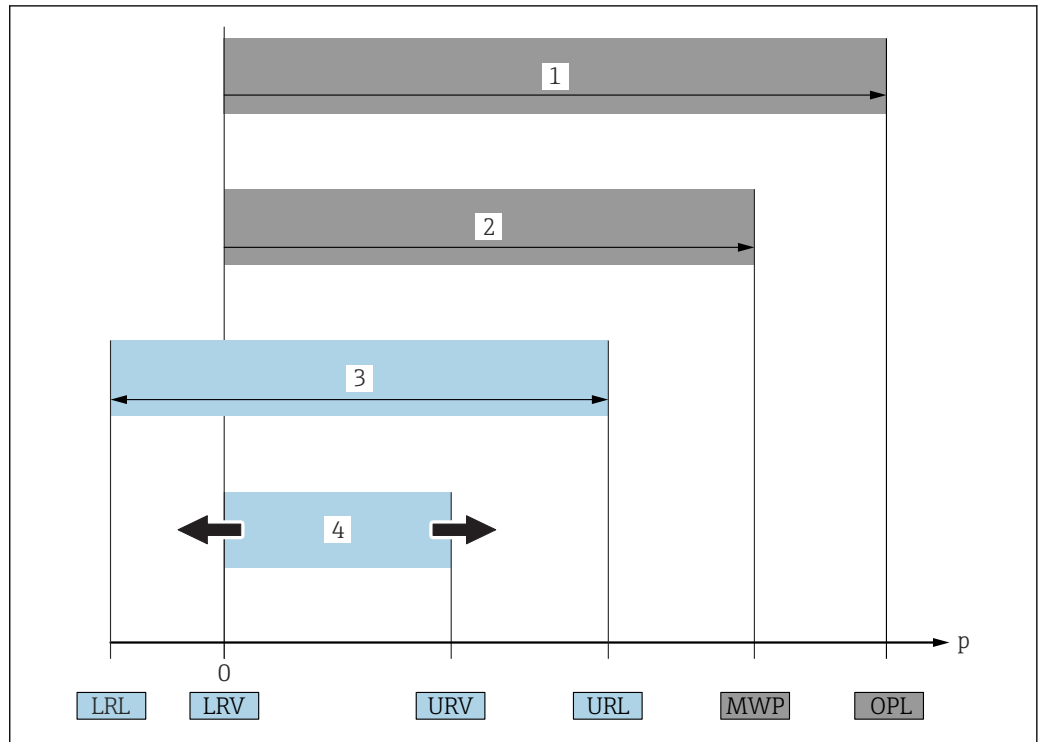

A0029505

Item	Term/ abbreviation	Explanation
1	OPL	The OPL (over pressure limit = sensor overload limit) for the measuring device depends on the lowest-rated element, with regard to pressure, of the selected components, i.e. the process connection has to be taken into consideration in addition to the measuring cell. Also observe pressure-temperature dependency. For the relevant standards and additional notes, see the "Pressure specifications" section → 37 . The OPL may only be applied for a limited period of time.
2	MWP	The MWP (maximum working pressure) for the sensors depends on the lowest-rated element, with regard to pressure, of the selected components, i.e. the process connection has to be taken into consideration in addition to the measuring cell. Also observe pressure-temperature dependency. For the relevant standards and additional notes, see the "Pressure specifications" section → 37 . The MWP may be applied at the device for an unlimited period. The MWP can also be found on the nameplate.
3	Maximum sensor measuring range	Span between LRL and URL This sensor measuring range is equivalent to the maximum calibratable/adjustable span.
4	Calibrated/ adjusted span	Span between LRV and URV Factory setting: 0 to URL Other calibrated spans can be ordered as customized spans.
p	-	Pressure
-	LRL	Lower range limit
-	URL	Upper range limit
-	LRV	Lower range value
-	URV	Upper range value
-	TD (turn down)	Turn down The turn down is preset at the factory and cannot be changed. Example - see the following section.

1.5 Turn down calculation

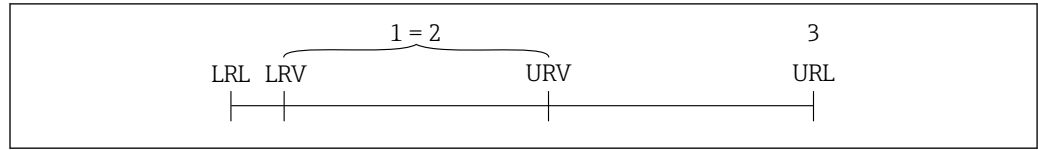

A0029545

- 1 Calibrated/adjusted span
- 2 Zero point-based span
- 3 URL sensor

Example	
<ul style="list-style-type: none"> ■ Sensor: 10 bar (150 psi) ■ Upper range value (URL) = 10 bar (150 psi) <p>Turn down (TD):</p> $TD = \frac{URL}{ URV - LRV }$ $TD = \frac{10 \text{ bar (150 psi)}}{ 5 \text{ bar (75 psi)} - 0 \text{ bar (0 psi)} } = 2$	<ul style="list-style-type: none"> ■ Calibrated/adjusted span: 0 to 5 bar (0 to 75 psi) ■ Lower range value (LRV) = 0 bar (0 psi) ■ Upper range value (URV) = 5 bar (75 psi)
<p>In this example, the TD is 2:1. This span is based on the zero point.</p>	

2 Basic safety instructions

2.1 Requirements concerning the staff

The personnel for installation, commissioning, diagnostics and maintenance must fulfill the following requirements:

- ▶ Trained, qualified specialists: must have a relevant qualification for this specific function and task
- ▶ Are authorized by the plant owner/operator
- ▶ Are familiar with federal/national regulations
- ▶ Before beginning work, the specialist staff must have read and understood the instructions in the Operating Instructions and supplementary documentation as well as in the certificates (depending on the application)
- ▶ Following instructions and basic conditions

The operating personnel must fulfill the following requirements:

- ▶ Being instructed and authorized according to the requirements of the task by the facility's owner-operator
- ▶ Following the instructions in these Operating Instructions

2.2 Designated use

2.2.1 Application and media

The Cerabar is used to measure absolute and gauge pressure in gases, vapors and liquids. The process-wetted materials of the measuring device must have an adequate level of resistance to the media.

The measuring device may be used for the following measurements (process variables)

- in compliance with the limit values specified under "Technical data"
- in compliance with the conditions that are listed in additional documentation such as the XA and this manual.

Measured process variable

- PMP11: gauge pressure
- PMP21: gauge pressure or absolute pressure
- PMP23: gauge pressure or absolute pressure

Calculated process variable

Pressure

2.2.2 Incorrect use

The manufacturer is not liable for damage caused by improper or non-designated use.

Verification for borderline cases:

- ▶ For special fluids and fluids for cleaning, Endress+Hauser is glad to provide assistance in verifying the corrosion resistance of process-wetted materials, but does not accept any warranty or liability.

2.2.3 Residual risks

When in operation, the housing may reach a temperature close to the process temperature.

Danger of burns from contact with surfaces!

- ▶ For elevated process temperatures, ensure protection against contact to prevent burns.

2.3 Workplace safety

For work on and with the device:

- ▶ Wear the required personal protective equipment according to federal/national regulations.
- ▶ Switch off the supply voltage before connecting the device.

2.4 Operational safety

Risk of injury!

- ▶ Operate the device in proper technical condition and fail-safe condition only.
- ▶ The operator is responsible for interference-free operation of the device.

Conversions to the device

Unauthorized modifications to the device are not permitted and can lead to unforeseeable dangers.

- ▶ If, despite this, modifications are required, consult with Endress+Hauser.

Hazardous area

To eliminate the risk of danger to persons or the facility when the device is used in the approval-related area (e.g. explosion protection, pressure equipment safety):

- ▶ Check the nameplate to verify if the device ordered can be put to its intended use in the approval-related area.
- ▶ Observe the specifications in the separate supplementary documentation, such as the XA or SD, which is an integral part of these Instructions.



2.5 Product safety

This measuring device is designed in accordance with good engineering practice to meet state-of-the-art safety requirements, has been tested, and left the factory in a condition in which it is safe to operate.

It meets general safety standards and legal requirements. It also complies with the EU directives listed in the device-specific EU Declaration of Conformity. Endress+Hauser confirms this by affixing the CE mark to the device.

3 Product description

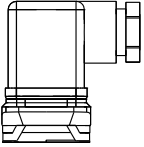
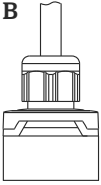
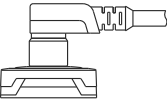
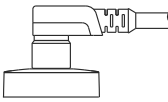
3.1 Product design

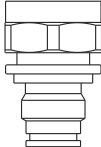
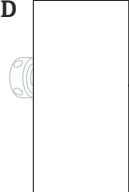
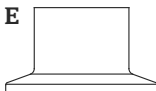
Overview	Item	Description
	A	Valve plug
	B	Cable
	C- 1	M12 plug Housing cap made of plastic
	C- 2	M12 plug For Ex eC and IP69: metal housing cap Metal housing cap can also be ordered as an option.
	D	Housing
	E	Process connection (sample illustration)
		
		

3.2 Function

3.2.1 Calculating the pressure

Devices with metallic process isolating diaphragm

The process pressure deflects the metal process isolating diaphragm of the sensor and a fill fluid transfers the pressure to a Wheatstone bridge (semiconductor technology). The pressure-dependent change in the bridge output voltage is measured and evaluated.

4 Incoming acceptance and product identification

4.1 Incoming acceptance

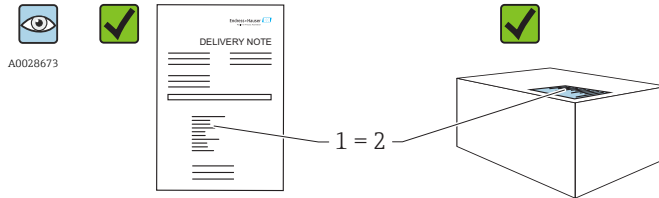

A0016870

Is the order code on the delivery note (1) identical to the order code on the product sticker (2)?

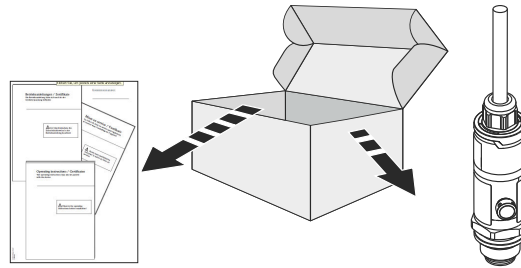

A0022100

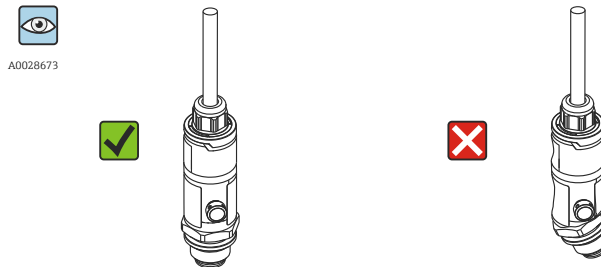

A0022103

Are the goods undamaged?

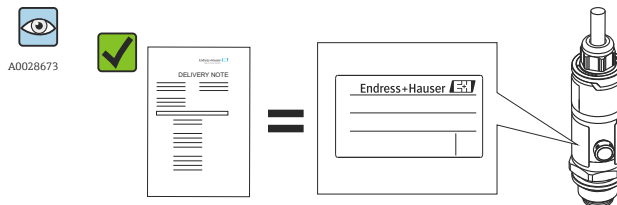

A0022105

Do the data on the nameplate correspond to the order specifications and the delivery note?

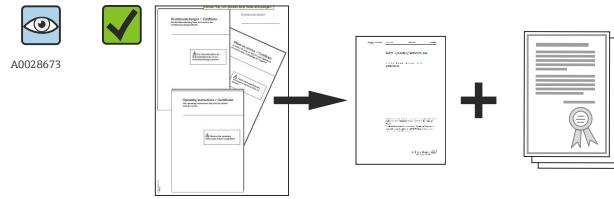

A0022106

Is the documentation available?
 If required (see nameplate): Are the safety instructions (XA) present?

i If one of these conditions does not apply, please contact your Endress+Hauser sales office.

4.2 Product identification

The following options are available for identification of the measuring device:

- Nameplate specifications
- Order code with breakdown of the device features on the delivery note
- Enter serial numbers from nameplates in *W@M Device Viewer* (www.endress.com/deviceviewer): All information about the measuring device is displayed.

For an overview of the technical documentation provided, enter the serial number from the nameplates in the *W@M Device Viewer* (www.endress.com/deviceviewer)

4.2.1 Nameplate

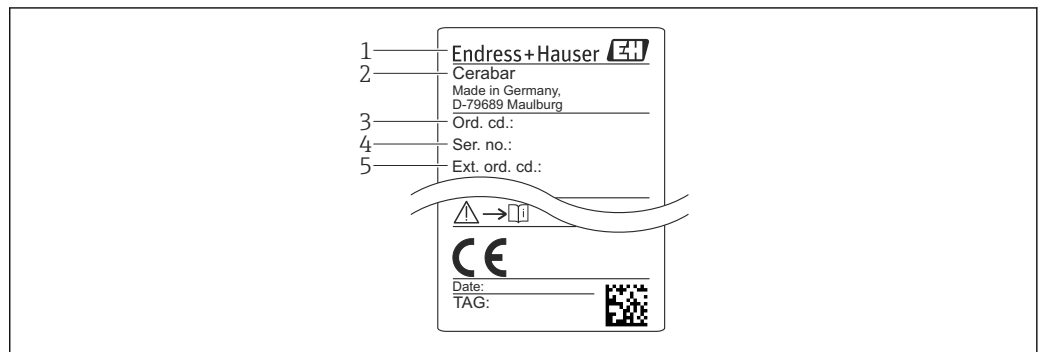

A0024456

- 1 Manufacturer's address
- 2 Device name
- 3 Order number
- 4 Serial number
- 5 Extended order number

4.3 Storage and transport

4.3.1 Storage conditions

Use original packaging.

Store the measuring device in clean and dry conditions and protect from damage caused by shocks (EN 837-2).

Storage temperature range

-40 to +85 °C (-40 to +185 °F)

4.3.2 Transporting the product to the measuring point

⚠ WARNING**Incorrect transport!**

Housing and diaphragm may become damaged, and there is a risk of injury!

- ▶ Transport the measuring device to the measuring point in its original packaging or by the process connection.

5 Installation

5.1 Mounting dimensions

For dimensions, see the "Mechanical construction" section in the Technical Information.

5.2 Installation conditions

- No moisture may enter the housing when installing or operating the device, or when establishing the electrical connection.
- For metal M12 plugs: Do not remove the protection cap (only for IP69 and Ex ec version) of the M12 plug terminal until shortly before the electrical connection.
- Do not clean or touch process isolating diaphragms with hard and/or pointed objects.
- Do not remove the protector on the process isolating diaphragm until just before installation.
- Always firmly tighten the cable entry.
- Point the cable and connector downwards where possible to prevent moisture from entering (e.g. rain or condensation water).
- Protect the housing from impact
- The following instruction applies for devices with a gauge pressure sensor and M12 plug or valve plug:

NOTICE

If a heated device is cooled during the cleaning process (e.g. by cold water), a vacuum develops for a short time, whereby moisture can penetrate the sensor through the pressure compensation element (1).

Device could be destroyed!

- ▶ In this case, mount the device with the pressure compensation element (1) pointing diagonally downwards where possible or to the side.

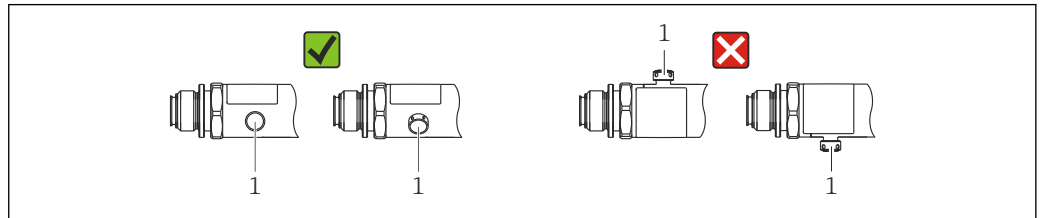

A0022252

5.3 Influence of the installation position

Any orientation is possible. However, the orientation may cause a zero point shift i.e. the measured value does not show zero when the vessel is empty or partially full.

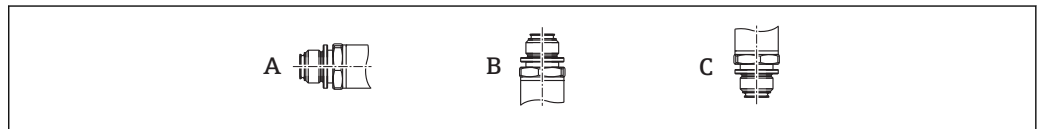

A0024708

Process isolating diaphragm axis is horizontal (A)	Process isolating diaphragm pointing upwards (B)	Process isolating diaphragm pointing downwards (C)
Calibration position, no effect	Up to +4 mbar (+0.058 psi)	Up to -4 mbar (-0.058 psi)

5.4 Mounting location

5.4.1 Pressure measurement

The pressure measurement specifications only apply for PMP11 and PMP21 devices.

Pressure measurement in gases

Mount the device with shutoff device above the tapping point so that any condensate can flow into the process.

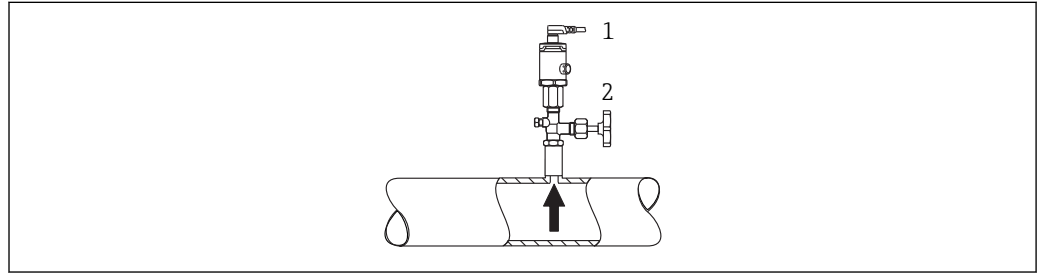

- 1 Device
2 Shutoff device

Pressure measurement in vapors

For pressure measurement in vapors, use a siphon. The siphon reduces the temperature to almost ambient temperature. Mount the device with a shutoff device at the same height as the tapping point.

Advantage:

only minor/negligible heat effects on the device.

Note the max. permitted ambient temperature of the transmitter!

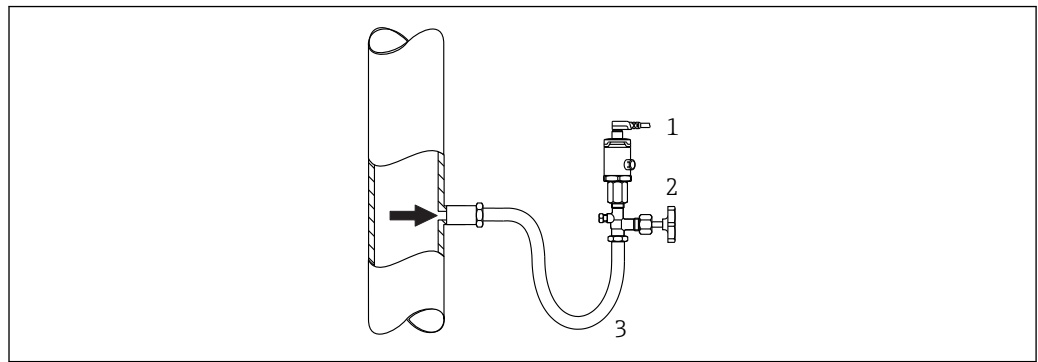

- 1 Device
2 Shutoff device
3 Siphon

Pressure measurement in liquids

Mount the device with a shutoff device at the same height as the tapping point.

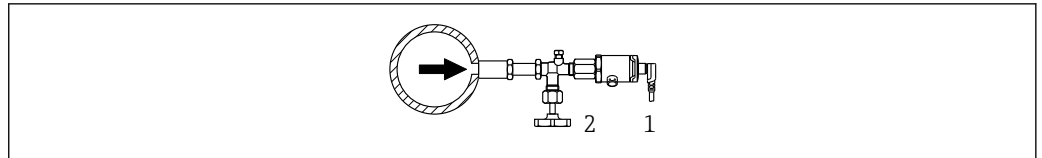

A0024399

- 1 Device
- 2 Shutoff device

5.4.2 Level measurement

- Always install the device below the lowest measuring point.
- Do not install the device at the following positions:
 - In the filling curtain
 - In the tank outlet
 - In the suction area of a pump
 - Or at a point in the tank which could be affected by pressure pulses from the agitator.

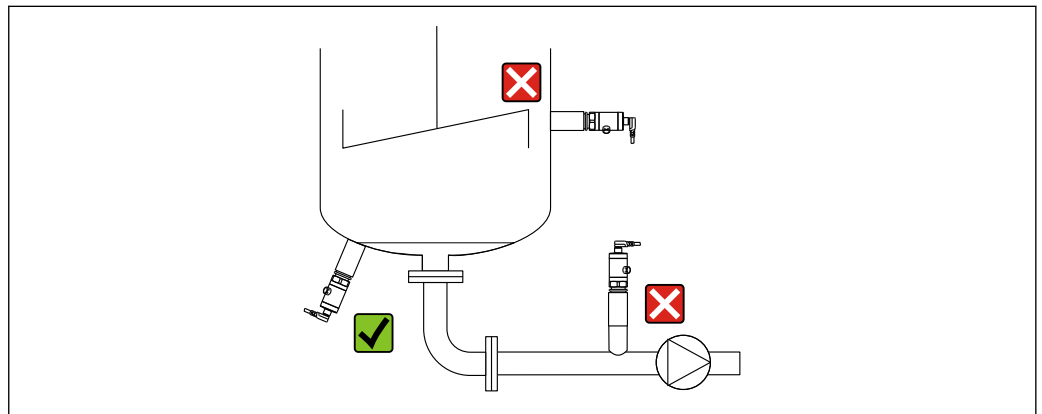

A0024405

5.5 Mounting the profiled seal for the universal process adapter

For details on mounting, see KA00096F/00/A3.

5.6 Post-installation check

<input type="checkbox"/>	Is the device undamaged (visual inspection)?
<input type="checkbox"/>	Does the device conform to the measuring point specifications? For example: <ul style="list-style-type: none"> ▪ Process temperature ▪ Process pressure ▪ Ambient temperature range ▪ Measuring range
<input type="checkbox"/>	Are the measuring point identification and labeling correct (visual inspection)?
<input type="checkbox"/>	Is the device adequately protected from precipitation and direct sunlight?
<input type="checkbox"/>	Are the securing screws tightened securely?
<input type="checkbox"/>	Does the pressure compensation element point downwards at an angle or to the side?
<input type="checkbox"/>	To prevent the penetration of moisture: are the connecting cables/plugs pointing downwards?

6 Electrical connection

6.1 Connecting the measuring unit

6.1.1 Terminal assignment

⚠ WARNING

Risk of injury from the uncontrolled activation of processes!

- ▶ Switch off the supply voltage before connecting the device.
- ▶ Make sure that downstream processes are not started unintentionally.

⚠ WARNING

Supply voltage might be connected!

Risk of explosion!

- ▶ Make sure that no supply voltage is applied when connecting.
- ▶ Switch off the supply voltage before connecting the device.

⚠ WARNING

Limitation of electrical safety due to incorrect connection!

- ▶ In accordance with IEC/EN61010 a separate circuit breaker must be provided for the device .
- ▶ The device must be operated with a 500 mA fine-wire fuse (slow-blow).
- ▶ When using the measuring device in hazardous areas, installation must comply with the corresponding national standards and regulations and the Safety Instructions or Installation or Control Drawings.
- ▶ All explosion protection data are given in separate documentation which is available upon request. The Ex documentation is supplied as standard with all devices approved for use in explosion hazardous areas.
- ▶ Protective circuits against reverse polarity are integrated.

Connect the device in the following order:

1. Check whether the supply voltage matches the supply voltage indicated on the nameplate.
2. Connect device in accordance with the following diagram.

Switch on supply voltage.

For devices with a cable connection: do not close reference air hose (see (a) in the following drawings)! Protect reference air hose against penetration by water/condensate.

4 to 20 mA output

Device	M12 plug	Valve plug	Cable
PMP11 PMP21 PMP23	<p>A0023487</p>	<p>A0022823</p>	<p>A0023783</p> <p>1 brown = L+ 2 blue = L- 3 green/yellow = ground connection (a) reference air hose</p>

0 to 10 V output

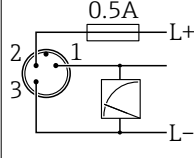
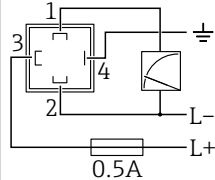
Device	M12 plug	Valve plug	Cable
PMP11	 <p style="text-align: right; font-size: small;">A0017576</p>	 <p style="text-align: right; font-size: small;">A0022822</p>	-

6.1.2 Supply voltage



Supply voltage might be connected!

Risk of explosion!

- ▶ When using the measuring device in hazardous areas, installation must comply with the corresponding national standards and regulations as well as the Safety Instructions.
- ▶ All explosion protection data are given in separate documentation which is available upon request. The Ex documentation is supplied as standard with all devices approved for use in explosion hazardous areas.

Electronic version	Device	Supply voltage
4 to 20 mA output	PMP11 PMP21 PMP23	10 to 30 V DC
0 to 10 V output	PMP11	12 to 30 V DC

6.1.3 Current consumption and alarm signal

Number of wires	Device	Normal operation	Alarm signal ¹⁾
2	PMP11 PMP21 PMP23	≤ 26 mA	> 21 mA
3	PMP11	< 12 mA	11 V

1) For MAX alarm (factory setting)

6.2 Connection conditions

6.2.1 Cable specification

For valve plug: < 1.5 mm² (16 AWG) and Ø3.5 to 6.5 mm (0.14 to 0.26 in)

6.3 Connection data

6.3.1 Load (for 4 to 20 mA devices)

In order to guarantee sufficient terminal voltage in two-wire devices, a maximum load resistance R_L (including line resistance) must not be exceeded, depending on the supply voltage U_B of the supply unit.

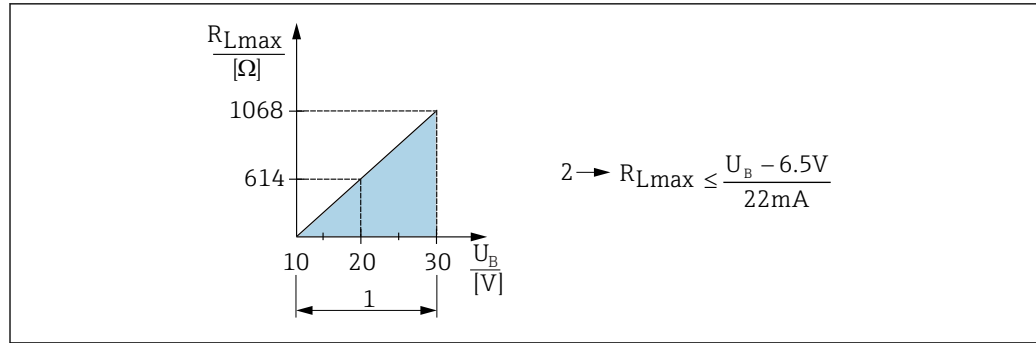

A0029452

- 1 Power supply 10 to 30 V DC
 2 R_{Lmax} maximum load resistance
 U_B Supply voltage

6.3.2 Load resistance (for 0 to 10 V devices)

The load resistance must be ≥ 5 [kΩ].

6.4 Post-connection check

<input type="checkbox"/>	Is the device or cable undamaged (visual check)?
<input type="checkbox"/>	Do the cables comply with the requirements ?
<input type="checkbox"/>	Do the cables have adequate strain relief?
<input type="checkbox"/>	Are all the cable glands installed, firmly tightened and leak-tight?
<input type="checkbox"/>	Does the supply voltage match the specifications on the nameplate?
<input type="checkbox"/>	Is the terminal assignment correct ?
<input type="checkbox"/>	If required: Has protective ground connection been established ?

7 Operation options

7.1 Plug-on display PHX20 (optional)

No display or other operation facility is required to operate the device. However, devices with a valve plug can be fitted with the optional local display PHX20.

A 1-line liquid crystal display (LCD) is used. The local display shows measured values, fault messages and information messages. The device display can be turned in 90° steps. Depending on the orientation of the device, it is therefore easy to read the measured values.

7.1.1 Storage conditions

- Use original packaging.
- Storage temperature range: -30 to +80 °C (-22 to +176 °F)

7.1.2 Installation

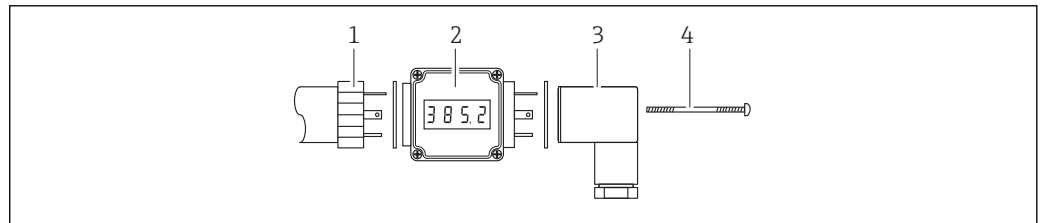

A0022208

1. Place seals between the sensor/plug-on display and the plug-on display/connector.
2. Fit the plug-on display (2) between the connector (3) and connector socket (1) of the sensor.
3. Replace the securing screw (4) with the longer screw included in the delivery.
4. An adhesive label (included in the delivery) with information on the technical unit can be fixed beneath the LED display.

Mounting dimensions

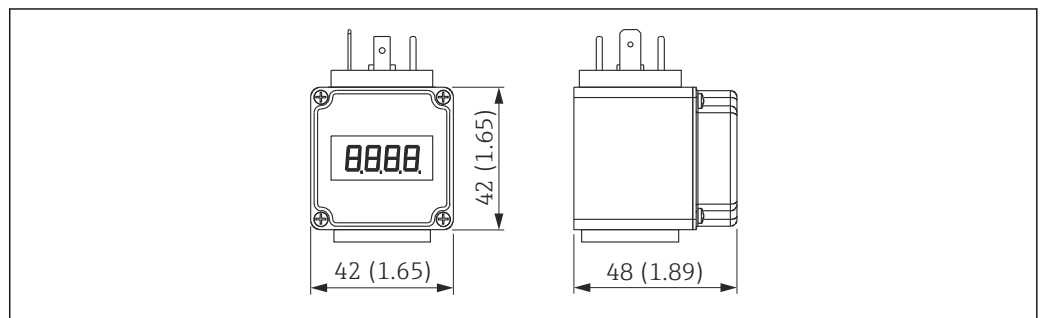

A0022210

7.1.3 Technical data

Display:	4-digit, red LED display
Digit height:	7.62 mm; programmable decimal point setting
Display range:	-1999 to 9999
Accuracy:	0.2% of the span ±1 digit

Electrical connection:	To transmitter with 4 to 20 mA output and elbow plug DIN 43 650, reverse polarity protection
Display power supply:	Not required, powered automatically from the power loop
Voltage drop:	≤ 5 V (corresponds to load: max. 250 Ω)
Rate of conversion:	3 measurements per second
Damping:	0.3 to 20 s (configurable)
Data backup:	Non-volatile EEPROM
Error message:	<ul style="list-style-type: none"> ▪ HI: overrange ▪ LO: below range
Programming:	Via 2 keys, menu-guided, display range scaling, decimal point, damping, error message
Degree of protection:	IP 65
Influence of temperature on the display:	0.1% / 10 K
Electromagnetic compatibility (EMC):	Interference emission as per EN 50081, interference immunity as per EN 50082
Permitted current load:	Max. 60 mA
Ambient temperature:	0 to +60 °C (+32 to +140 °F)
Housing material:	Pa6 GF30 plastic, blue Front screen made from red PMMA
Order number:	52022914

7.1.4 Electrical connection

Pin assignment



Is the supply voltage switched off?

Risk of electric shock!

- ▶ Switch off the supply voltage before connecting the device.

- PIN 1: L+ (supply voltage U_B)
- PIN 2: L- (0 V)
- PIN 3: Not assigned

Supply voltage

The supply voltage (mostly 24 V DC) must be greater than the sum of the voltage drop U_s at the sensor, the voltage drop of 5 V at the display and other voltage loss U_a (such as additional evaluation and power loss).

The following therefore applies: $U_b = U_s + 5 \text{ V} + U_a$

Post-connection check

<input type="checkbox"/>	Is the device or cable undamaged (visual check)?
<input type="checkbox"/>	Are all cable glands installed, securely tightened and leak-tight?
<input type="checkbox"/>	If supply voltage is present, is the device ready for operation and do values appear on the display module?

7.1.5 Commissioning

NOTICE

Risk of injury from the uncontrolled activation of processes!

- ▶ Ensure that no uncontrolled processes are activated in the system.

Configuring the menu items

To configure the menu items, loosen the 4 Phillips screws (1) on the display and remove the cover.

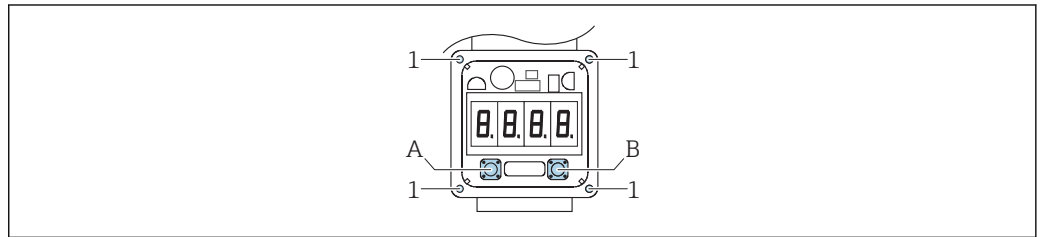

A0022209

- A Move down and select the items
- B Move up and select the items
- A+B Select the item to configure or acknowledge the setting

Setting the decimal point

Press the B key until "dP" is displayed.	d P
Press A+B to set the decimal point:	- - - . -
Press B or A for up or down:	- - . - -
Press A+B to quit the setting function and to go to the "dP" menu item.	d P

Out of range setting

Message if signal is below 4 mA or above 20 mA:

- "HI" message = over range
- "LO" message = below range

Press the B key until "HILO" is displayed.	H I L O
Press A+B for the setting function (message inactive):	o F F
Press B or A for up or down (message active):	o n
Press A+B to quit the setting function and to go to the "HILO" menu item.	H I L O

Please note: If the "HILO" message is not active, the error "Er06" is displayed if the display range (-1999 to +9999) is exceeded.

Changing to the measuring mode

Depending on the menu item selected, press key A or B between 1 and 8 times.

8 Diagnostics and troubleshooting

8.1 Troubleshooting

If an illegal configuration exists in the device, the device switches to error mode.

General errors

Error	Possible cause	Solution
Device is not responding.	Supply voltage does not match that specified on the nameplate.	Apply correct voltage.
	Supply voltage has incorrect polarity.	Reverse polarity of supply voltage.
	Connecting cables are not in contact with the terminals.	Check the contacting of the cables and correct if necessary.
Output current ≤ 3.6 mA	Signal line is not wired correctly.	Check wiring.

8.2 Response of output to errors

The response of the output to error is regulated in accordance with NAMUR NE43.

Factory setting MAX alarm: >21 mA

8.2.1 alarm current

Device	Description	Option
PMP21 PMP23	Adjusted min. alarm current	IA ¹⁾

1) Product Configurator order code for "Service"

8.3 Disposal

When disposing, separate and recycle the device components based on the materials.

9 Maintenance

No special maintenance work is required.

Keep the pressure compensation element (1) free from contamination.

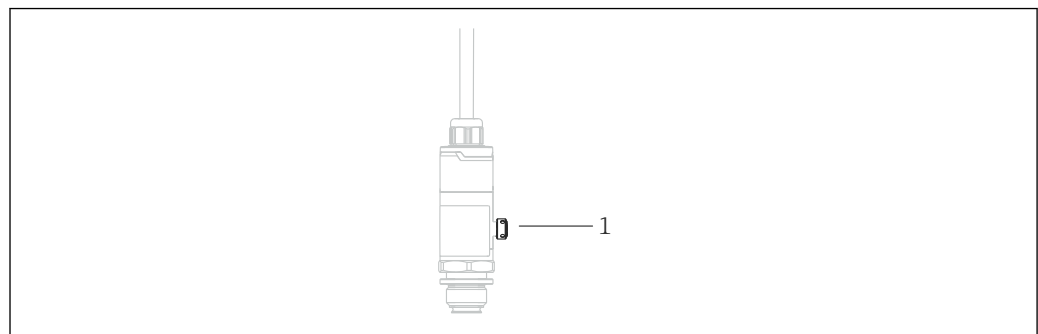

A0022141

9.1 Exterior cleaning

Please note the following points when cleaning the device:

- The cleaning agents used should not corrode the surface and the seals.
- Mechanical damage to the process isolating diaphragm, e.g. due to sharp objects, must be avoided.
- Observe the degree of protection of the device. See the nameplate if necessary →  13.

10 Repair

10.1 General notes

10.1.1 Repair concept

Repairs are not possible.

10.2 Return

The measuring device must be returned if the wrong device has been ordered or delivered.

As an ISO-certified company and also due to legal regulations, Endress+Hauser is obliged to follow certain procedures when handling any returned products that have been in contact with medium. To ensure swift, safe and professional device returns, please read the return procedures and conditions on the Endress+Hauser website at www.services.endress.com/return-material

11 Accessories

11.1 Weld-in adapter

Various weld-in adapters are available for installation in vessels or pipes.

Device	Description	Option ¹⁾	Order number
PMP23	Weld-in adapter M24, d=65, 316L	PM	71041381
PMP23	Weld-in adapter M24, d=65, 316L 3.1 EN10204-3.1 material, inspection certificate	PN	71041383
PMP21	Weld-in adapter G½, 316L	QA	52002643
PMP21	Weld-in adapter G½, 316L 3.1 EN10204-3.1 material, inspection certificate	QB	52010172
PMP21	Weld-in tool adapter G½, brass	QC	52005082
PMP23	Weld-in adapter G1, 316L, conical metal joint	QE	52005087
PMP23	Weld-in adapter G1, 316L, 3.1, conical metal joint, EN10204-3.1 material, inspection certificate	QF	52010171
PMP23	Weld-in tool adapter G1, brass	QG	52005272
PMP23	Weld-in adapter G1, 316L, silicone O-ring seal	QJ	52001051
PMP23	Weld-in adapter G1, 316L, 3.1, silicone O-ring seal, EN10204-3.1 material, inspection certificate	QK	52011896
PMP23	Weld-in adapter Uni D65, 316L	QL	214880-0002
PMP23	Weld-in adapter Uni D65, 316L 3.1 EN10204-3.1 material, inspection certificate	QM	52010174
PMP23	Weld-in tool adapter Uni D65/D85, brass	QN	71114210
PMP23	Weld-in adapter Uni D85, 316L	QP	52006262
PMP23	Weld-in adapter Uni D85, 316L 3.1 EN10204-3.1 material, inspection certificate	QR	52010173

1) Product Configurator, order code for "Enclosed accessories"

If installed horizontally and weld-in adapters with a leakage hole are used, ensure that the leakage hole is pointing down. This allows leaks to be detected as quickly as possible.

11.2 Process adapter M24

The following process adapters can be ordered for the process connections with order option X2J and X3J:

Device	Description	Order number	Order number with inspection certificate 3.1 EN10204
PMP23	Varivent F DN32 PN40	52023996	52024003
PMP23	Varivent N DN50 PN40	52023997	52024004
PMP23	DIN11851 DN40	52023999	52024006
PMP23	DIN11851 DN50	52023998	52024005
PMP23	SMS 1½"	52026997	52026999
PMP23	Clamp 1½"	52023994	52024001
PMP23	Clamp 2"	52023995	52024002

11.3 Plug-on display PHX20

→  21

11.4 M12 plug connectors

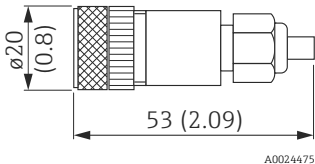
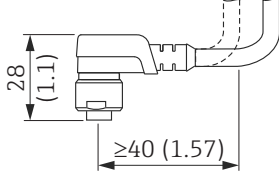
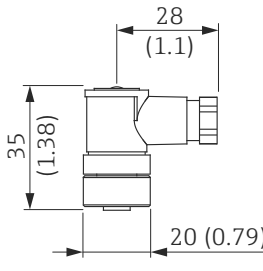
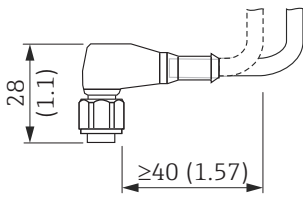
Connector	Degree of protection	Material	Option ¹⁾	Order number
M12 (self-terminated connection at M12 plug) 	IP67	<ul style="list-style-type: none"> ▪ Union nut: Cu Sn/Ni ▪ Body: PBT ▪ Seal: NBR 	R1	52006263
M12 90 degrees with 5m (16 ft) cable 	IP67	<ul style="list-style-type: none"> ▪ Union nut: GD Zn/Ni ▪ Body: PUR ▪ Cable: PVC 	RZ	52010285
M12 90 degrees (self-terminated connection at M12 plug) 	IP67	<ul style="list-style-type: none"> ▪ Union nut: GD Zn/Ni ▪ Body: PBT ▪ Seal: NBR 	RM	71114212
M12 90 degrees with 5m (16 ft) cable (terminated at one end) 	IP69 ²⁾	<ul style="list-style-type: none"> ▪ Union nut: 316L (1.4435) ▪ Body and cable: PVC and PUR 	RW	52024216

1) Product Configurator, order code for "Enclosed accessories"

2) Designation of the IP protection class according to DIN EN 60529. Previous designation "IP69K" according to DIN 40050 Part 9 is no longer valid (standard withdrawn on November 1, 2012). The tests required by both standards are identical.

12 Technical data

12.1 Input

12.1.1 Measured variable

Measured process variable

- PMP11: gauge pressure
- PMP21: gauge pressure or absolute pressure
- PMP23: gauge pressure or absolute pressure

Calculated process variable

Pressure

12.1.2 Measuring range

Metal process isolating diaphragm

Sensor	Device	Maximum Sensor measuring range		Lowest calibratable span ¹⁾	MWP	OPL	Factory settings ²⁾	Option ³⁾
		lower (LRL)	upper (URL)					
		[bar (psi)]	[bar (psi)]					
Devices for gauge pressure measurement								
400 mbar (6 psi) ⁴⁾	PMP11 PMP21 PMP23	-0.4 (-6)	+0.4 (+6)	0.4 (0.6)	1 (15)	1.6 (24)	0 to 400 mbar (0 to 6 psi)	1F
1 bar (15 psi) ⁴⁾	PMP11 PMP21 PMP23	-1 (-15)	+1 (+15)	1 (15)	2.7 (40.5)	4 (60)	0 to 1 bar (0 to 15 psi)	1H
2 bar (30 psi) ⁴⁾	PMP11 PMP21 PMP23	-1 (-15)	+2 (+30)	0.4 (0.6)	6.7 (100.5)	10 (150)	0 to 2 bar (0 to 30 psi)	1K
4 bar (60 psi) ⁴⁾	PMP11 PMP21 PMP23	-1 (-15)	+4 (+60)	0.8 (1.2)	10.7 (160.5)	16 (240)	0 to 4 bar (0 to 60 psi)	1M
6 bar (90 psi) ⁴⁾	PMP11 PMP21 PMP23	-1 (-15)	+6 (+90)	2 (30)	16 (240)	24 (360)	0 to 6 bar (0 to 90 psi)	1N
10 bar (150 psi) ⁴⁾	PMP11 PMP21 PMP23	-1 (-15)	+10 (+150)	2 (30)	25 (375)	40 (600)	0 to 10 bar (0 to 150 psi)	1P
16 bar (240 psi) ⁴⁾	PMP11 PMP21 PMP23	-1 (-15)	+16 (+240)	5 (75)	25 (375)	64 (960)	0 to 16 bar (0 to 240 psi)	1Q
25 bar (375 psi) ⁴⁾	PMP11 PMP21 PMP23	-1 (-15)	+25 (+375)	5 (75)	25 (375)	100 (1500)	0 to 25 bar (0 to 375 psi)	1R
40 bar (600 psi) ⁴⁾	PMP11 PMP21 PMP23	-1 (-15)	+40 (+600)	8 (120)	100 (1500)	160 (2400)	0 to 40 bar (0 to 600 psi)	1S
100 bar (1500 psi) ⁴⁾	PMP21	-1 (-15)	+100 (+1500)	20 (300)	100 (1500)	160 (2400)	0 to 100 bar (0 to 1500 psi)	1U
400 bar (6000 psi) ⁴⁾	PMP21	-1 (-15)	+400 (+6000)	80 (1200)	400 (6000)	600 (9000)	0 to 400 bar (0 to 6000 psi)	1W

Sensor	Device	Maximum Sensor measuring range		Lowest calibratable span ¹⁾	MWP	OPL	Factory settings ²⁾	Option ³⁾
		lower (LRL)	upper (URL)					
		[bar (psi)]	[bar (psi)]					
Devices for absolute pressure measurement								
400 mbar (6 psi) ⁴⁾	PMP21 PMP23	0 (0)	0.4 (+6)	0.4 (0.6)	1 (15)	1.6 (24)	0 to 400 mbar (0 to 6 psi)	2F
1 bar (15 psi) ⁴⁾	PMP21 PMP23	0 (0)	1 (+15)	1 (15)	2.7 (40.5)	4 (60)	0 to 1 bar (0 to 15 psi)	2H
2 bar (30 psi) ⁴⁾	PMP21 PMP23	0 (0)	2 (+30)	0.4 (0.6)	6.7 (100.5)	10 (150)	0 to 2 bar (0 to 30 psi)	2K
4 bar (60 psi) ⁴⁾	PMP21 PMP23	0 (0)	4 (+60)	0.8 (1.2)	10.7 (160.5)	16 (240)	0 to 4 bar (0 to 60 psi)	2M
10 bar (150 psi) ⁴⁾	PMP21 PMP23	0 (0)	10 (+150)	2 (30)	25 (375)	40 (600)	0 to 10 bar (0 to 150 psi)	2P
40 bar (600 psi) ⁴⁾	PMP21 PMP23	0 (0)	+40 (+600)	8 (120)	100 (1500)	160 (2400)	0 to 40 bar (0 to 600 psi)	2S
100 bar (1 500 psi) ⁴⁾	PMP21	0 (0)	+100 (+1500)	20 (300)	100 (1500)	160 (2400)	0 to 100 bar (0 to 1 500 psi)	2U
400 bar (6 000 psi) ⁴⁾	PMP21	0 (0)	+400 (+6000)	80 (1200)	400 (6000)	600 (9000)	0 to 400 bar (0 to 6 000 psi)	2W

- 1) Highest turn down that can be set at the factory: 5:1. The turn down is preset and cannot be changed.
- 2) Other measuring ranges (e.g. -1 to +5 bar (-15 to 75 psi)) can be ordered with customer-specific settings (see the Product Configurator, order code for "Calibration; Unit" option "J"). It is possible to invert the output signal (LRV = 20 mA; URV = 4 mA). Prerequisite: URV < LRV
- 3) Product Configurator, order code for "Sensor range"
- 4) Vacuum resistance: 0.01 bar (0.145 psi)

Maximum turn down which can be ordered for absolute pressure and gauge pressure sensors

Device	Range	400 mbar (6 psi)	1 bar (15 psi) 6 bar (90 psi) 16 bar (240 psi)	2 bar (30 psi) 4 bar (60 psi) 10 bar (150 psi) 25 to 400 bar (375 to 6 000 psi)
PMP11	0.5%	TD 1:1	TD 1:1 to TD 2.5:1	TD 1:1 to TD 5:1
PMP21	0.3%	TD 1:1	TD 1:1 to TD 2.5:1	TD 1:1 to TD 5:1
PMP23	0.3%	TD 1:1	TD 1:1 to TD 2.5:1	TD 1:1 to TD 5:1

12.2 Output

12.2.1 Output signal

Description	Option ¹⁾
4 to 20 mA (2-wire)	1
PMP11: 0 to 10 V output (3-wire)	2

1) Product Configurator, order code for "Output"

12.2.2 Signal range 4 to 20 mA

3.8 mA to 20.5 mA

12.2.3 Load (for 4 to 20 mA devices)

In order to guarantee sufficient terminal voltage in two-wire devices, a maximum load resistance R_L (including line resistance) must not be exceeded, depending on the supply voltage U_B of the supply unit.

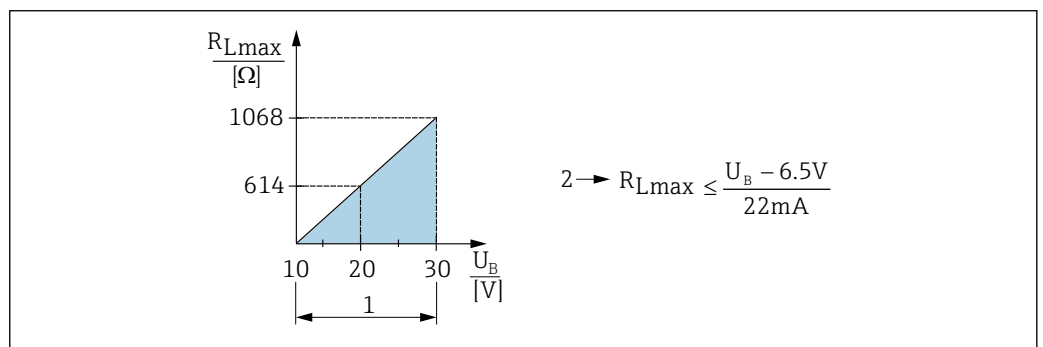

- 1 Power supply 10 to 30 V DC
- 2 R_{Lmax} maximum load resistance
- U_B Supply voltage

12.2.4 Load resistance (for 0 to 10 V devices)

The load resistance must be ≥ 5 [kΩ].

12.2.5 Signal on alarm 4 to 20 mA

The response of the output to error is regulated in accordance with NAMUR NE43.

Factory setting MAX alarm: >21 mA

alarm current

Device	Description	Option
PMP21 PMP23	Adjusted min. alarm current	IA ¹⁾

1) Product Configurator order code for "Service"

12.2.6 Dead time, time constant

Presentation of the dead time and the time constant:

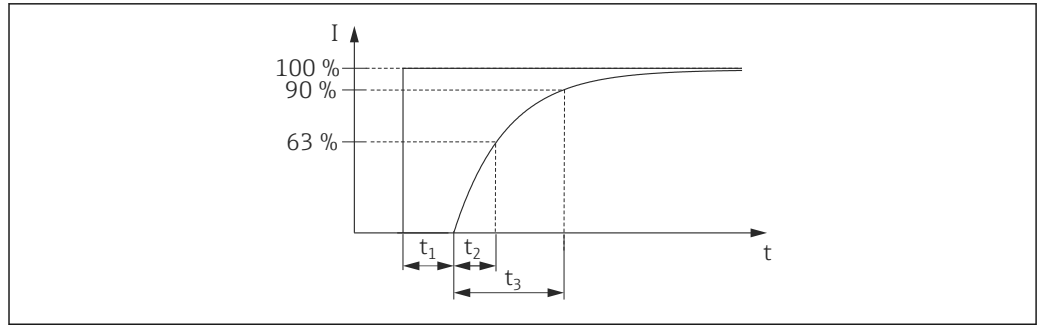

A0019786

12.2.7 Dynamic behavior

Analog electronics

Dead time (t_1) [ms]	Time constant (T63), t_2 [ms]	Time constant (T90), t_3 [ms]
6 ms	10 ms	15 ms

12.3 Performance characteristics of metallic process isolating diaphragm

12.3.1 Reference operating conditions

- As per IEC 60770
- Ambient temperature T_A = constant, in the range of: +21 to +33 °C (+70 to +91 °F)
- Humidity φ = constant, in the range of 5 to 80 % rH
- Ambient pressure p_A = constant, in the range of: 860 to 1 060 mbar (12.47 to 15.37 psi)
- Position of measuring cell = constant, in range: horizontal $\pm 1^\circ$ (see also "Influence of the installation position" section →  15)
- Zero based span
- Process isolating diaphragm material: AISI 316L (1.4435)
- Filling oil: NSF-H1 synthetic oil in accordance with FDA 21 CFR 178.3570
- Supply voltage: 24 V DC ± 3 V DC
- Load: 320 Ω

12.3.2 Measuring uncertainty for small absolute pressure measuring ranges

The smallest extended uncertainty of measurement that can delivered by our standards is:

- in range 1 to 30 mbar (0.0145 to 0.435 psi): 0.4 % of reading
- in range < 1 mbar (0.0145 psi): 1 % of reading.

12.3.3 Influence of the installation position

→  15

12.3.4 Resolution

Current output: min. 1.6 μ A

12.3.5 Reference accuracy

The reference accuracy contains the non-linearity [DIN EN 61298-2 3.11] including the pressure hysteresis [DIN EN 61298-23.13] and non-repeatability [DIN EN 61298-2 3.11] in accordance with the limit point method as per [DIN EN 60770].

Device	TD ¹⁾	% of calibrated span	% of typical non-linearity	% of typical non-repeatability
PMP11	TD 1:1 to TD 5:1	± 0.5	± 0.1	± 0.1
PMP21	TD 1:1 to TD 5:1	± 0.3	± 0.1	± 0.1
PMP23	TD 1:1 to TD 5:1	± 0.3	± 0.1	± 0.1

1) Overview of the turn down ranges →  30

12.3.6 Thermal change of the zero output and the output span

PMP11, PMP21

Measuring cell	-20 to +85 °C (-4 to +185 °F)		-20 to -40 °C (-4 to -40 °F) +85 to +100 °C (+185 to +212 °F)	
	% of the calibrated span for TD 1:1			
<1 bar (15 psi)	<1		<1.2	
≥ 1 bar (15 psi)	<0.8		<1	

PMP23

Measuring cell	-10 to +85 °C (+14 to +185 °F)	+85 to +100 °C (+185 to +212 °F)
	% of the calibrated span for TD 1:1	
<1 bar (15 psi)	<1	<1.2
≥ 1 bar (15 psi)	<0.8	<1

12.3.7 Long-term stability

Measuring ranges	1 year	5 years	10 year
	% of URL		
400 mbar (6 psi) to 400 bar (6 000 psi)	±0.2	±0.4	In preparation

12.3.8 Switch-on time

≤2 s

12.4 Environment

12.4.1 Ambient temperature range

Device	Ambient temperature range ¹⁾
PMP11	-40 to +70 °C (-40 to +158 °F)
PMP21 PMP23	-40 to +85 °C (-40 to +185 °F)
PMP21 PMP23	Devices for hazardous areas: -40 to +70 °C (-40 to +158 °F)

- 1) Exception: the following cable is designed for an operating temperature range of -25 to +70 °C (-13 to +158 °F): Product Configurator order code for "Accessory enclosed", option "RZ".

12.4.2 Storage temperature range

-40 to +85 °C (-40 to +185 °F)

12.4.3 Climate class

Device	Climate class	Note
PMP23	Class 4K4H	Air temperature: -20 to +55 °C (-4 to +131 °F), relative humidity: 4 to 100 % satisfied according to DIN EN 60721-3-4 (condensation is possible)
PMP11 PMP21	Class 3K5	Air temperature: -5 to +45 °C (+23 to +113 °F), relative humidity: 4 to 95 % satisfied according to IEC 721-3-3 (condensation not possible)

12.4.4 Degree of protection

Device	Connection	Climate class	Option ¹⁾
PMP21 PMP23	Cable 5 m (16 ft)	IP66/68 ²⁾ NEMA Type 4X/6P Enclosure	A
PMP21 PMP23	Cable 10 m (33 ft)	IP66/68 ²⁾ NEMA Type 4X/6P Enclosure	B
PMP21 PMP23	Cable 25 m (82 ft)	IP66/68 ²⁾ NEMA Type 4X/6P Enclosure	C
PMP11	M12 plug made of plastic	IP65 NEMA type 4X enclosure	L
PMP21 PMP23	M12 plug made of plastic	IP65/67 NEMA type 4X enclosure	M
PMP23	M12 plug made of metal	IP66/69 ³⁾ NEMA type 4X enclosure	N
PMP11 PMP21 PMP23	Valve plug ISO4400 M16	IP65 NEMA type 4X enclosure	U
PMP11 PMP21 PMP23	Valve plug ISO4400 NPT ½	IP65 NEMA type 4X enclosure	V

- 1) Product Configurator, order code for "Electrical connection"
 2) IP 68 (1.83 mH2O for 24 h)
 3) Designation of the IP protection class according to DIN EN 60529. Previous designation "IP69K" according to DIN 40050 Part 9 is no longer valid (standard withdrawn on November 1, 2012). The tests required by both standards are identical.

12.4.5 Vibration resistance

Test standard	Vibration resistance
IEC 60068-2-64:2008	Guaranteed for 5 to 2000Hz: 0.05g ² /Hz

12.4.6 Electromagnetic compatibility

- Interference emission as per EN 61326-1 equipment B
- Interference immunity as per EN 61326-1 (industrial sector)
- NAMUR recommendation EMC (NE21)
- Maximum deviation: 1.5% for TD 1:1

For further details refer to the Declaration of Conformity.

12.5 Process

12.5.1 Process temperature range for devices with metallic process isolating diaphragm

Device	Process temperature range
PMP11	-25 to +85 °C (-13 to +185 °F)
PMP21	-40 to +100 °C (-40 to +212 °F)
PMP23	-10 to +100 °C (+14 to +212 °F)
PMP23 Sterilization in place (SIP)	At +135°C (+275 °F) for a maximum of one hour (device in operation but not within measuring specification)

Applications with changes in temperature

Frequent extreme changes in temperatures can temporarily cause measuring errors. Internal temperature compensation is faster the smaller the change in temperature and the longer the time interval.

For further information please contact your local Endress+Hauser Sales Center.

12.5.2 Pressure specifications

⚠ WARNING

The maximum pressure for the measuring device depends on the lowest-rated element with regard to pressure.

- ▶ For pressure specifications, see the "Measuring range" section and "Mechanical construction" section in the Technical Information.
- ▶ The Pressure Equipment Directive (2014/68/EU) uses the abbreviation "PS". The abbreviation "PS" corresponds to the MWP (maximum working pressure) of the measuring device.
- ▶ MWP (maximum working pressure): The MWP (maximum working pressure) is specified on the nameplate. This value is based on a reference temperature of +20 °C (+68 °F) and may be applied to the device for an unlimited period of time. Observe the temperature dependency of the MWP.
- ▶ OPL (over pressure limit): The test pressure corresponds to the over pressure limit of the sensor and may only be applied temporarily to ensure that the measurement is within the specifications and no permanent damage develops. In the case of sensor range and process connections where the over pressure limit (OPL) of the process connection is smaller than the nominal value of the sensor, the device is set at the factory, at the very maximum, to the OPL value of the process connection. If you want to use the entire sensor range, select a process connection with a higher OPL value.

Index

A

Application 9

C

CE mark (declaration of conformity) 10

Cleaning 25

D

Declaration of Conformity 10

Designated use 9

Disposal 24

E

Exterior cleaning 25

F

Field of application

Residual risks 9

M

Maintenance 24

Media 9

N

Nameplate 13

O

Operational safety 10

P

Product safety 10

R

Repair concept 26

S

Safety instructions

Basic 9

Safety Instructions (XA) 5

Staff

Requirements 9

T

Troubleshooting 24

U

Use of the measuring device

see Designated use

Use of the measuring devices

Borderline cases 9

Incorrect use 9

W

Workplace safety 10



71336273

www.addresses.endress.com
