

### Reliable Thumbwheel with Easy-to-Mount Assembly

- Dustproof construction ensures highly reliable performance at low voltage and very small current even under adverse environmental conditions
- Plus (+) and minus (–) pushbuttons for positive forward and reverse rotation of each digital wheel

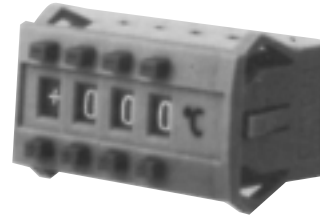

### Ordering Information

#### ■ SWITCH UNITS

Output Code	Part Number			
	Front mounting solder terminals			
	Stopper pin provided		Stopper pin not provided	
	Light gray case	Black case	Light gray case	Black case
03 (decimal code)	–	–	<b>A7BS-203</b>	<b>A7BS-203-1</b>
06 (binary code) (binary code w/+, – display)	<b>A7BS-206-S</b>	<b>A7BS-206-S-1</b>	<b>A7BS-206</b>	<b>A7BS-206-1</b>
	–	–	<b>A7BS-206-PM</b>	<b>A7BS-206-PM-1</b>
07 (binary code w/diode provision)	<b>A7BS-207-S</b>	<b>A7BS-207-S-1</b>	<b>A7BS-207</b>	<b>A7BS-207-1</b>
19 (decimal code w/component adding provision)	–	–	<b>A7BS-219</b>	<b>A7BS-219-1</b>
54 (binary code hexadecimal)	–	–	<b>A7BS-254</b>	<b>A7BS-254-1</b>
55 (binary code hexadecimal, w/component adding provision)	–	–	<b>A7BS-255</b>	<b>A7BS-255-1</b>

#### ■ ACCESSORIES

Accessory	Part Number		
	For front mounting type switch assembly terminals		
	Light gray	Black	
End Cap	<b>A7B-M</b>	<b>A7B-M-1</b>	
Spacer	<b>A7B-P□</b>	<b>A7B-P□-1</b>	
Connector	Solder terminal	<b>A7B-C</b>	<b>A7B-C</b>
	PC terminal	<b>A7B-CP</b>	<b>A7B-CP</b>

- Note: 1. When placing your order, please specify the model numbers and quantities of required switch units, end caps, and spacers, respectively. (Note that switch units and accessories are not factory-assembled for shipment.)
2. Type with a suffix -S in their type number are provided with two stopper pins (Type A7BS-S: used in pairs) as standard accessories.
3. Switch case, end cap, and spacer are made of polyacetal resin; however, the window plate is polycarbonate resin.
4. One of the following alphabetic codes must be filled into the boxed part of the model number to specify a legend to be hot stamped on the required spacer.
5. End caps come as a set -- left and right.

Code	Legend	Code	Legend	Code	Legend
A	Hot stamp not required	E	g	K	°C
B	SEC	F	kg	L	PCS
C	MIN	G	mm	Q	x 10 SEC
D	H	H	cm	T	0
		J	m		

# Characteristics

Switching capacity		1 mA to 0.1 A 50 VAC/28 VDC (resistive load)
Carry current		1 A (max.)
Contact resistance		200 mΩ max.
Insulation resistance		10 MΩ min. (at 500 VDC) between nonconnected terminals 1,000 MΩ min. (at 500 VDC) between each terminal and noncurrent-carrying part
Dielectric strength		600 VAC, 50/60 Hz for 1 minute between nonconnected terminals 1,000 VAC, 50/60 Hz for 1 minute between each terminal and noncurrent-carrying part
Operating force		550 g max.
Vibration		10 to 55 Hz, 1.5 mm double amplitude
Shock		500 m/s <sup>2</sup> (approx. 50 G)
Ambient temperature	Operating	-10° to 65°C
	Storage	-20° to 80°C
Humidity		45% to 85% RH max.
Service life	Mechanical	100,000 operations (steps) min.
	Electrical	50,000 operations (steps) min.
Weight (per unit)		Approx. 4.1 g

Note: Data shown are of initial value.

# Dimensions

Unit: mm (inch)

## SWITCH UNITS

A7BS-206(-1)

A7BS-207(-1)

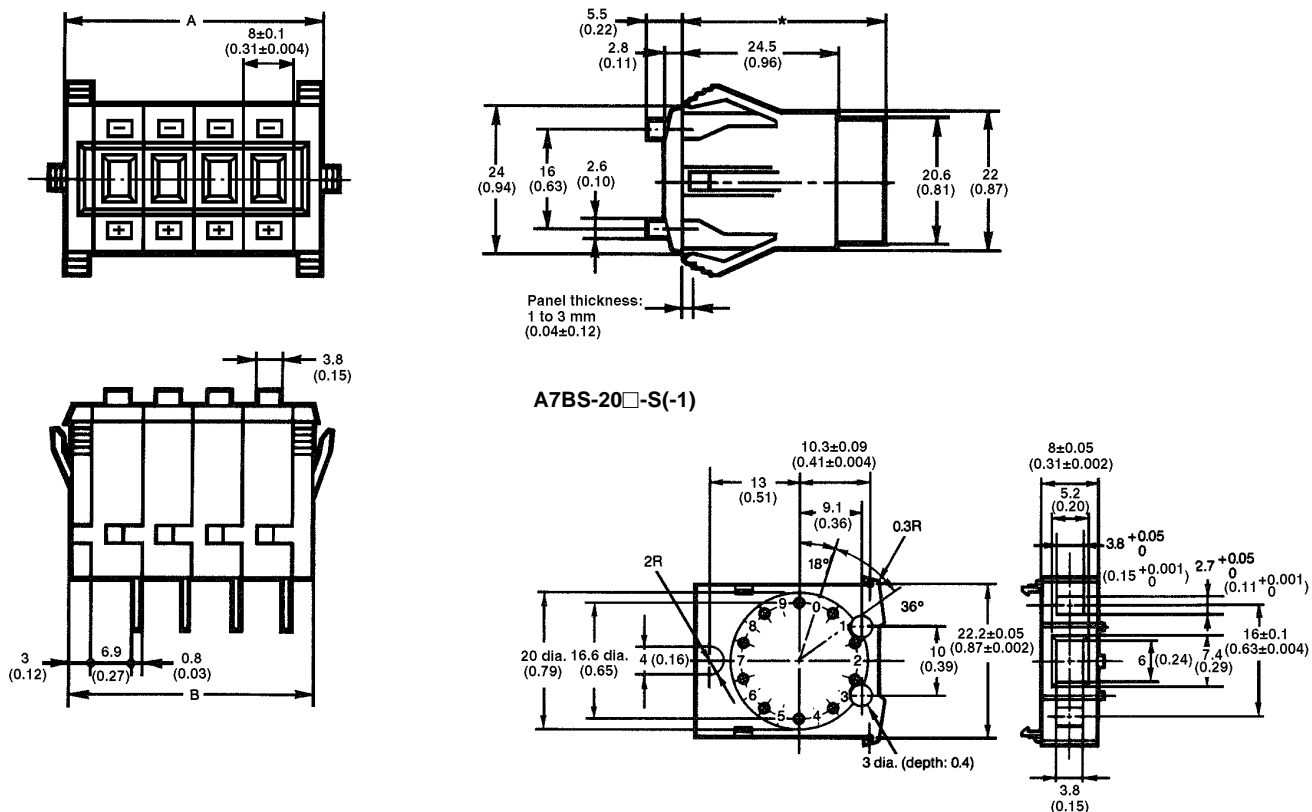

Note: Dimension \* is 32.5 (1.28) for the switch with output code "06" [i.e., A7BS-206(-1)], and 43.5 (1.71) for the switch with output code "07" [i.e., A7BS-207(-1)].

Panel cutout

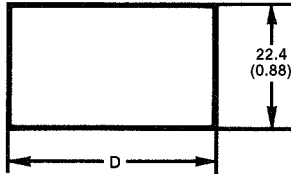

No. of units (n)	A (8n + 8)	B (8n + 6)	D
1	16 (0.63)	14 (0.55)	14.4 (0.57)
2	24 (0.94)	22 (0.87)	22.4 (0.88)
3	32 (1.26)	30 (1.18)	30.4 (1.20)
4	40 (1.57)	38 (1.50)	38.4 (1.51)
5	48 ± 0.8 (1.89 ± 0.03)	46 ± 0.8 (1.81 ± 0.03)	46.8 (1.84)
6	56 ± 0.8 (2.20 ± 0.03)	54 ± 0.8 (2.13 ± 0.03)	54.8 (2.16)
7	64 ± 0.8 (2.52 ± 0.03)	62 ± 0.8 (2.44 ± 0.03)	62.8 (2.47)
8	72 ± 0.8 (2.83 ± 0.03)	70 ± 0.8 (2.76 ± 0.03)	70.8 (2.79)
9	80 ± 0.8 (3.15 ± 0.03)	78 ± 0.8 (3.07 ± 0.03)	78.8 (3.10)
10	88 ± 0.8 (3.46 ± 0.03)	86 ± 0.8 (3.39 ± 0.03)	86.8 (3.42)

Note: 1. Unless otherwise specified, a tolerance of ± 0.4 mm applies to all dimensions.

2. Each model number applies to a single switch unit and not to the switch assembly as shown in the drawings.

■ END CAPS

A7B-M(-1)

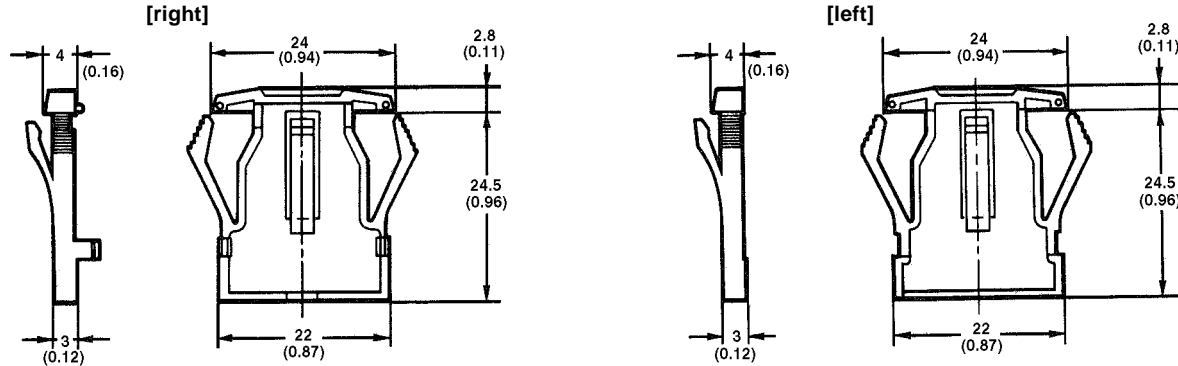

Note: End caps are attached to each end of the switch assembly and used to secure the switch assembly to a mounting panel.

■ STOPPER PINS

A7BS-S

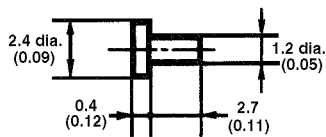

Note: Types with Suffix -S in their type numbers are provided with two stopper pins as standard accessories.

■ SPACERS

A7B-P□(-1)

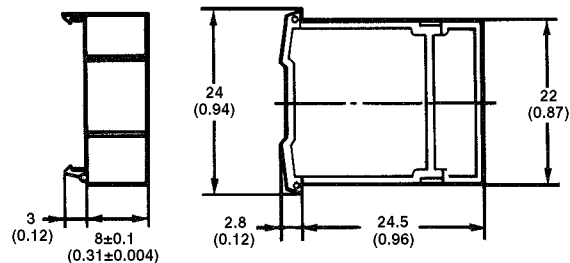

Unit: mm (inch)

■ CONNECTORS

A7B-C

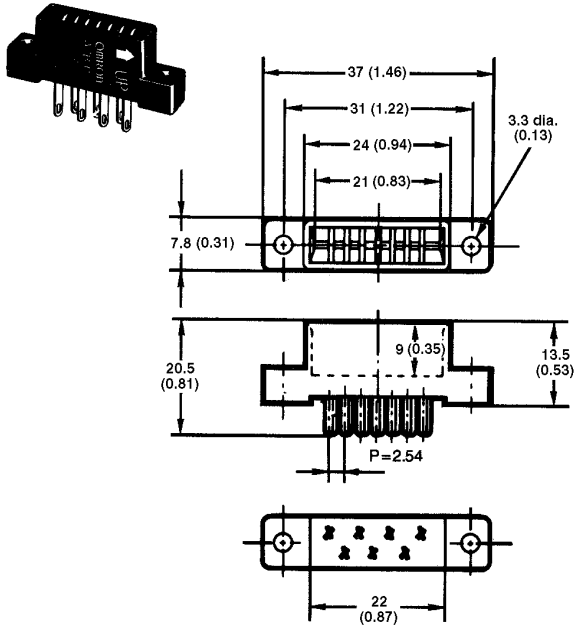

A7B-CP

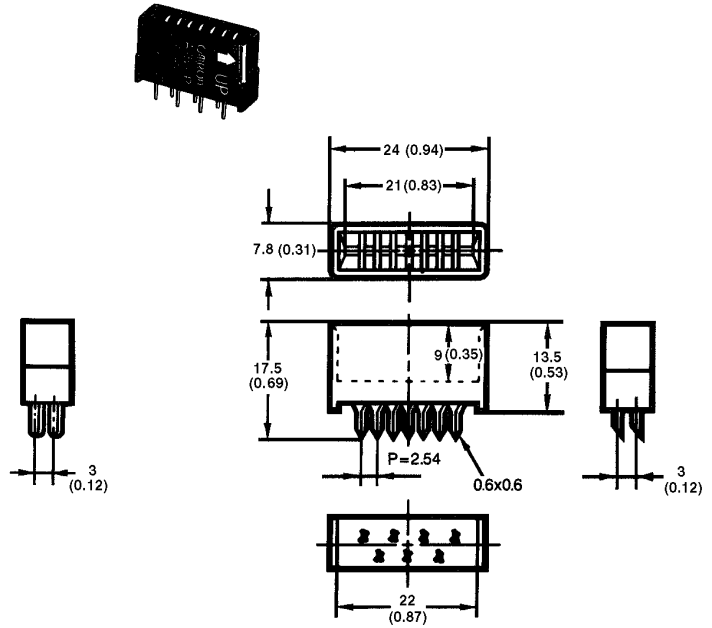

■ TERMINALS

A7BS-206(-1)

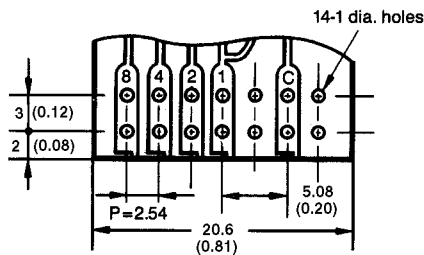

A7BS-207(-1)

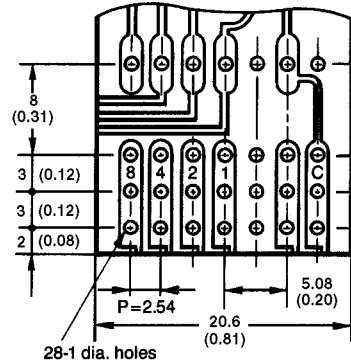

Hints on Correct Use

Refer to HINTS ON CORRECT USE under the General Information section.



**OMRON ELECTRONICS, INC.**  
 One East Commerce Drive  
 Schaumburg, IL 60173  
**1-800-55-OMRON**

**OMRON CANADA, INC.**  
 885 Milner Avenue  
 Scarborough, Ontario M1B 5V8  
**416-286-6465**