



TS79M00

3-Terminal Medium Current Negative Voltage Regulators

TO-220



TO-252

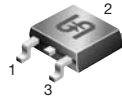

Pin: 1. Ground 2. Input 3. Output
(Heatsink surface connected to Pin 2.)

Voltage Range
-5 to -24 Volts
Current
500 mA

Features

- ✧ No External Components Required
- ✧ Internal Thermal Overload Protection
- ✧ Internal Short Circuit Current Limiting
- ✧ Output Transistor Safe-Area Compensation
- ✧ Output Voltage Offered in 4% Tolerance

Ordering Informations

Device	Operating Temperature (Ambient)	Package
TS79MxxCZ	-20 °C ~ +85°C	TO-220
TS79MxxCP		TO-252

Absolute Maximum Ratings (Ta=25°C, unless otherwise noted.)

Rating	Symbol	Value	Unit
Input Voltage (-5.0V~ -15V) (-18V~ -24V)	V _{in}	-35 -40	Vdc
Power Dissipation (Package Limitation) Plastic Package, TO-220 TA=25°C	P _D	Internally Limited	
Thermal Resistance, Junction-to-Air	θ _{JA}	70	°C/W
Thermal Resistance, Junction-to-Case	θ _{JC}	5.0	°C/W
Plastic Package, DPAK (TO-252) TA=25°C	P _D	Internally Limited	
Thermal Resistance, Junction-to-Air	θ _{JA}	92	°C/W
Thermal Resistance, Junction-to-Case	θ _{JC}	5.0	°C/W
Operating Junction Temperature Range	T _j	+150	°C
Storage Temperature Range	T _{stg}	-65 to +150	°C

Rev. 1 02/2003



TS79M05 Electrical Characteristics (Vin= -10V, Io=350mA, 0°CATJA125°C, PDA5.0W)						
Characteristics		Symbol	Min.	Typ.	Max.	Unit
Output Voltage	(Tj=25°C)	Vo	-4.8	-5.0	-5.2	Vdc
	(-7.0VdcAVinA-20Vdc, 5.0mAIoA350mA)		-4.75	-5.0	-5.25	
Line Regulation (Tj=25°C, -7.0VdcAVinA-25Vdc, Io=200mA)		REGline	-	3.0	50	mV
Load Regulation (Tj=25°C, 5.0mAIoA500mA)		REGload	-	20	100	mV
(Tj=25°C, 5.0mAIoA200mA)			-	10	50	
Input Bias Current (Tj=25°C)		IIB	-	3.2	8.0	mA
Quiescent Current Change (-8.0VdcAVinA-25Vdc, Io=200mA)		OIIB	-	-	0.8	mA
(5.0mAIoA350mA)			-	-	0.5	
Output Noise Voltage (Ta=25°C, 10HzAfA100kHz)		Vn	-	40	-	µA
Ripple Rejection (Io=100mA, f=120Hz, -9.0VAVinA-19V)		RR	62	-	-	dB
(Io=300mA, f=120Hz, -9.0VAVinA-19V, Tj=25°C)			62	80	-	
Dropout Voltage (Tj=25°C)		Vin-Vo	-	2.0	-	Vdc
Short Circuit Current Limit (Tj=25°C, Vin=-35V)		Ios	-	50	-	mA
Average Temperature Coefficient of Output Voltage (Io=5.0mA)		OV0/OT	-	0.4	-	mV/°C
Peak Output Current (Tj=25°C)		Io	-	700	-	mA
TS79M06 Electrical Characteristics (Vin= -11V, Io=350mA, 0°CATJA125°C, PDA5.0W, unless otherwise noted)						
Characteristics		Symbol	Min.	Typ.	Max.	Unit
Output Voltage	(Tj=25°C)	Vo	-5.75	-6	-6.25	Vdc
	(-8.0VdcAVinA-21Vdc, 5.0mAIoA350mA)		-5.70	-6	-6.30	
Line Regulation (Tj=25°C, -8.0VdcAVinA-25Vdc, Io=200mA)		REGline	-	3.0	50	mV
Load Regulation (Tj=25°C, 5.0mAIoA500mA)		REGload	-	20	120	mV
(Tj=25°C, 5.0mAIoA200mA)			-	10	60	
Input Bias Current (Tj=25°C)		IIB	-	3.2	8.0	mA
Quiescent Current Change (-9.0VdcAVinA-25Vdc, Io=200mA)		OIIB	-	-	0.8	mA
(5.0mAIoA350mA)			-	-	0.5	
Output Noise Voltage (Ta=25°C, 10HzAfA100kHz)		Vn	-	45	-	µA
Ripple Rejection (Io=100mA, f=120Hz, -9.0VAVinA-19V)		RR	59	-	-	dB
(Io=300mA, f=120Hz, -9.0VAVinA-19V, Tj=25°C)			59	80	-	
Dropout Voltage (Tj=25°C)		Vin-Vo	-	2.0	-	Vdc
Short Circuit Current Limit (Tj=25°C, Vin=-35V)		Ios	-	50	-	mA
Average Temperature Coefficient of Output Voltage (Io=5.0mA)		OV0/OT	-	0.4	-	mV/°C
Peak Output Current (Tj=25°C)		Io	-	700	-	mA

Rev. 1 02/2003



TS79M08 Electrical Characteristics

(Vin= -14V, Io=350mA, 0°CATjA125°C, PDA5.0W, unless otherwise noted)

Characteristics		Symbol	Min.	Typ.	Max.	Unit
Output Voltage	(Tj=25°C)	Vo	-7.70	-8	-8.30	Vdc
	(-10.5VdcAVinA123Vdc, 5mAAlO A350mA)		-7.84	-8	-8.16	
Line Regulation (Tj=25°C, -10.5VdcAVinA125Vdc, Io=200mA)		REGline	-	60	50	mV
Load Regulation (Tj=25°C, 5.0mAAlO A500mA) (Tj=25°C, 5.0mAAlO A200mA)		REGload	-	25	160	mV
			-	10	80	
Input Bias Current (Tj=25°C)		IIB	-	3.2	8.0	mA
Quiescent Current Change (-10.5VdcAVinA-25Vdc,Io=200mA) (5.0mAAlO A350mA)		OIIB	-	-	0.8	mA
			-	-	0.5	
Output Noise Voltage (Ta=25°C, 10HzAfA100kHz)		Vn	-	52	-	µV
Ripple Rejection (Io=100mA, f=120Hz, -11.5VAVinA-21.5V) (Io=300mA, f=120Hz, -11.5VAVinA-21.5V, Tj=25°C)		RR	56	-	-	dB
			56	80	-	
Dropout Voltage (Tj=25°C)		Vin-Vo	-	2.0	-	Vdc
Short Circuit Current Limit (Tj=25°C, Vin=-35V)		Ios	-	50	-	mA
Average Temperature Coefficient of Output Voltage (Io=5.0mA)		OVo/OT	-	0.4	-	mV/°C
Peak Output Current (Tj=25°C)		Io	-	700	-	mA

TS79M09 Electrical Characteristics

(Vin= -15V, Io=350mA, 0°CATjA125°C, PDA5.0W, unless otherwise noted)

Characteristics		Symbol	Min.	Typ.	Max.	Unit
Output Voltage	(Tj=25°C)	Vo	-8.64	-9	-9.36	Vdc
	(-11.5VdcAVinA123Vdc, 5mAAlO A350mA)		-8.55	-9	-9.45	
Line Regulation (Tj=25°C, -11.5VdcAVinA125Vdc, Io=200mA)		REGline	-	60	50	mV
Load Regulation (Tj=25°C, 5.0mAAlO A500mA) (Tj=25°C, 5.0mAAlO A200mA)		REGload	-	25	180	mV
			-	10	90	
Input Bias Current (Tj=25°C)		IIB	-	3.2	8.0	mA
Quiescent Current Change (-11.5VdcAVinA-25Vdc,Io=200mA) (5.0mAAlO A350mA)		OIIB	-	-	0.8	mA
			-	-	0.5	
Output Noise Voltage (Ta=25°C, 10HzAfA100kHz)		Vn	-	52	-	µV
Ripple Rejection (Io=100mA, f=120Hz, -12.5VAVinA-22.5V) (Io=300mA, f=120Hz, -12.5VAVinA-22.5V, Tj=25°C)		RR	56	-	-	dB
			56	80	-	
Dropout Voltage (Tj=25°C)		Vin-Vo	-	2.0	-	Vdc
Short Circuit Current Limit (Tj=25°C, Vin=-35V)		Ios	-	50	-	mA
Average Temperature Coefficient of Output Voltage (Io=5.0mA)		OVo/OT	-	0.4	-	mV/°C
Peak Output Current (Tj=25°C)		Io	-	700	-	mA

Rev. 1 02/2003



TS79M12 Electrical Characteristics						
(Vin= -19V, Io=350mA, 0°CATJA125°C, PDA5.0W, unless otherwise noted)						
Characteristics		Symbol	Min.	Typ.	Max.	Unit
Output Voltage	(Tj=25°C)	Vo	-11.52	-12	-12.48	Vdc
	(-14.5VdcAVinA±27Vdc, 5mAAlIoA350mA)		-11.40	-12	-12.60	
Line Regulation (Tj=25°C, -14.5VdcAVinA±80Vdc, Io=200mA)		REGline	-	80	50	mV
Load Regulation (Tj=25°C, 5.0mAAlIoA500mA) (Tj=25°C, 5.0mAAlIoA200mA)		REGload	-	25	240	mV
			-	10	120	
Input Bias Current (Tj=25°C)		IIB	-	3.2	8.0	mA
Quiescent Current Change (-14.5VdcAVinA-30Vdc, Io=200mA) (5.0mAAlIoA350mA)		OIIB	-	-	0.8 0.5	mA
Output Noise Voltage (Ta=25°C, 10HzAfA100kHz)		Vn	-	75	-	µV
Ripple Rejection (Io=100mA, f=120Hz, -15VAVinA-25V) (Io=300mA, f=120Hz, -15VAVinA-25V, Tj=25°C)		RR	55	-	-	dB
			55	80	-	
Dropout Voltage (Tj=25°C)		Vin-Vo	-	2.0	-	Vdc
Short Circuit Current Limit (Tj=25°C, Vin=-35V)		Ios	-	50	-	mA
Average Temperature Coefficient of Output Voltage (Io=5.0mA)		OVo/OT	-	0.4	-	mV/°C
Peak Output Current (Tj=25°C)		Io	-	700	-	mA
TS79M15 Electrical Characteristics						
(Vin= -19V, Io=350mA, 0°CATJA125°C, PDA5.0W, unless otherwise noted) (Note 5)						
Characteristics		Symbol	Min.	Typ.	Max.	Unit
Output Voltage	(Tj=25°C)	Vo	-14.40	-15	-15.60	Vdc
	(-17.5VdcAVinA±80Vdc, 5mAAlIoA350mA)		-14.25	-15	-15.75	
Line Regulation (Tj=25°C, -17.5VdcAVinA±80Vdc, Io=200mA)		REGline	-	10	50	mV
Load Regulation (Tj=25°C, 5.0mAAlIoA500mA) (Tj=25°C, 5.0mAAlIoA200mA)		REGload	-	25	300	mV
			-	10	150	
Input Bias Current (Tj=25°C)		IIB	-	3.2	8.0	mA
Quiescent Current Change (-17.5VdcAVinA-30Vdc, Io=200mA) (5.0mAAlIoA350mA)		OIIB	-	-	0.8 0.5	mA
Output Noise Voltage (Ta=25°C, 10HzAfA100kHz)		Vn	-	90	-	µV
Ripple Rejection (Io=100mA, f=120Hz, -18.5VAVinA-28.5V) (Io=300mA, f=120Hz, -18.5VAVinA-28.5V, Tj=25°C)		RR	54	-	-	dB
			54	70	-	
Dropout Voltage (Tj=25°C)		Vin-Vo	-	2.0	-	Vdc
Short Circuit Current Limit (Tj=25°C, Vin=-35V)		Ios	-	50	-	mA
Average Temperature Coefficient of Output Voltage (Io=5.0mA)		OVo/OT	-	0.4	-	mV/°C
Peak Output Current (Tj=25°C)		Io	-	700	-	mA

Rev. 1 02/2003



TS79M18 Electrical Characteristics

(Vin= -23V, Io=350mA, 0°CATjA125°C, PDA5.0W, unless otherwise noted)

Characteristics		Symbol	Min.	Typ.	Max.	Unit
Output Voltage	(Tj=25°C)	Vo	-17.28	-18	-18.72	Vdc
	(-21VdcAVinA483Vdc, 5mAAlO A350mA)		-17.10	-18	-18.90	
Line Regulation (Tj=25°C, -21VdcAVinA483Vdc, Io=200mA)		REGline	-	10	50	mV
Load Regulation (Tj=25°C, 5.0mAAlO A500mA) (Tj=25°C, 5.0mAAlO A200mA)		REGload	-	30	360	mV
			-	10	180	
Input Bias Current (Tj=25°C)		IIB	-	3.2	9	mA
Quiescent Current Change (-21VdcAVinA-33Vdc, Io=200mA) (5.0mAAlO A350mA)		OIIB	-	-	0.8	mA
			-	-	0.5	
Output Noise Voltage (Ta=25°C, 10HzAfA100kHz)		Vn	-	100	-	µV
Ripple Rejection (Io=100mA, f=120Hz, -22VAVinA-32V) (Io=300mA, f=120Hz, -22VAVinA-32V, Tj=25°C)		RR	53	-	-	dB
			53	70	-	
Dropout Voltage (Tj=25°C)		Vin-Vo	-	2.0	-	Vdc
Short Circuit Current Limit (Tj=25°C, Vin=-35V)		Ios	-	50	-	mA
Average Temperature Coefficient of Output Voltage (Io=5.0mA)		OVo/OT	-	0.4	-	mV/°C
Peak Output Current (Tj=25°C)		Io	-	700	-	mA

TS79M24 Electrical Characteristics

(Vin= -27V, Io=350mA, 0°CATjA125°C, PDA5.0W, unless otherwise noted)

Characteristics		Symbol	Min.	Typ.	Max.	Unit
Output Voltage	(Tj=25°C)	Vo	-23.0	-24	-25.0	Vdc
	(-27VdcAVinA488Vdc, 5.0mAAlO A350mA)		-22.8	-24	-25.2	
Line Regulation (Tj=25°C, -27VdcAVinA488Vdc, Io=200mA)		REGline	-	10	50	mV
Load Regulation (Tj=25°C, 5.0mAAlO A500mA) (Tj=25°C, 5.0mAAlO A200mA)		REGload	-	30	480	mV
			-	10	240	
Input Bias Current (Tj=25°C)		IIB	-	3.2	9	mA
Quiescent Current Change (-27VdcAVinA-38Vdc, Io=200mA) (5.0mAAlO A350mA)		OIIB	-	-	0.8	mA
			-	-	0.5	
Output Noise Voltage (Ta=25°C, 10HzAfA100kHz)		Vn	-	170	-	µV
Ripple Rejection (Io=100mA, f=120Hz, -28VAVinA-38V) (Io=300mA, f=120Hz, -28VAVinA-38V, Tj=25°C)		RR	50	-	-	dB
			50	70	-	
Dropout Voltage (Tj=25°C)		Vin-Vo	-	2.0	-	Vdc
Short Circuit Current Limit (Tj=25°C, Vin=-35V)		Ios	-	50	-	mA
Average Temperature Coefficient of Output Voltage (Io=5.0mA)		OVo/OT	-	0.4	-	mV/°C
Peak Output Current (Tj=25°C)		Io	-	700	-	mA

Rev. 1 02/2003

Definitions

Line-Regulation: The change in output voltage for a change in the input voltage. The measurement is made under conditions of low dissipation or by using pulse techniques such that the average chip temperature is not significantly affected.

Load-Regulation: The change in output voltage for a change in load current at constant chip temperature.

Maximum Power dissipation: The maximum total device dissipation for which the regulator will operate within specifications.

Input Bias Current: That part of the input current that is not delivered to the load.

Output Noise Voltage: The rms AC voltage at the output, with constant load and no input ripple, measured over a specified frequency range.

Long Term Stability: Output voltage stability under accelerated life test conditions with the maximum rated voltage listed in the devices' electrical characteristics and maximum power dissipation.

FIG.1- WORST CASE POWER DISSIPATION VERSUS AMBIENT TEMPERATURE (TO-220)

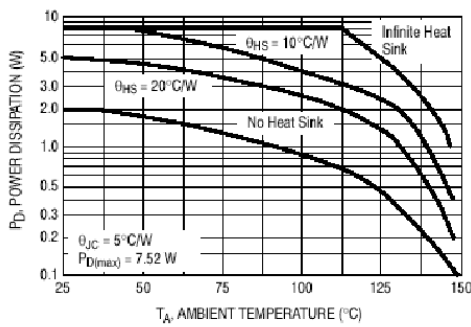
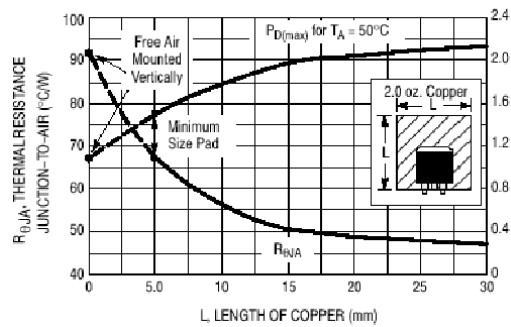
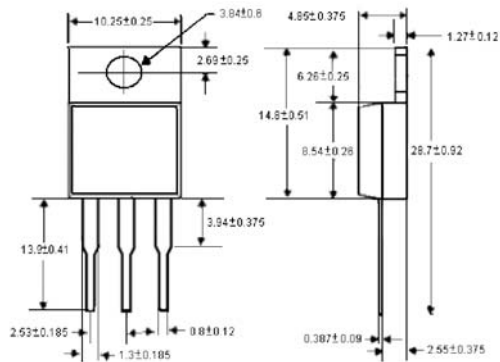

FIG.2- DPAK THERMAL RESISTANCE AND MAXIMUM POWER DISSIPATION VERSUS P.C.B. COPPER LENGTH



TO-220 Unit: mm



TO-252 Unit: mm

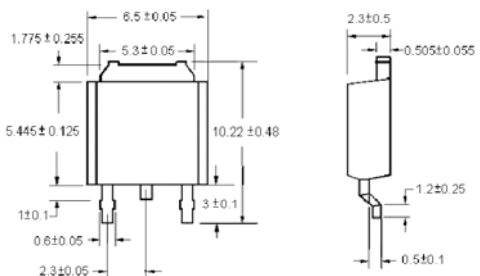



Applications Information

Design Considerations

The TS79Mxx Series of fixed voltage regulators are designed with Thermal Overload Protection that shuts down the circuit when subjected to an excessive power overload condition, Internal Short Circuit Protection that limits the maximum current the circuit will pass, and Output Transistor Safe-Area Compensation that reduces the output short circuit current as the voltage across the pass transistor is increased.

In many low current applications, compensation capacitors are not required. However, it is recommended that the regulator input be bypassed with a capacitor if the regulator is connected to the power supply filter with long wire lengths, or if the output load capacitance is large. An input bypass capacitor should be selected to provide good high frequency characteristics to insure stable operation under all load conditions. A 0.33 mF or larger tantalum, Mylar, or other capacitor having low internal impedance at high frequencies should be chosen. The bypass capacitor should be mounted with the shortest possible leads directly across the regulator's input terminals. Normally good construction techniques should be used to minimize ground loops and lead resistance drops since the regulator has no external sense lead.

FIG.3- REPRESENTATIVE SCHEMATIC DIAGRAM

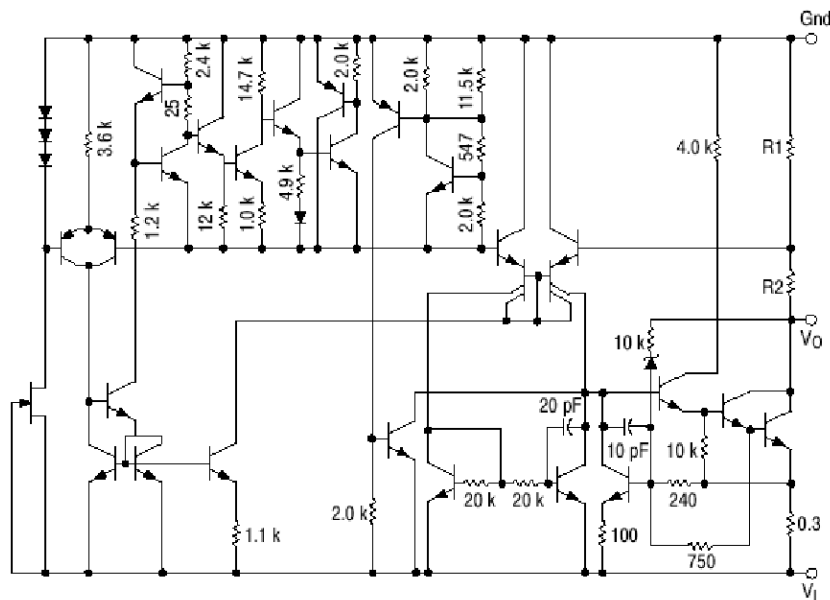

Rev. 1 02/2003