



Industrial mSATA Specification

(ACHIEVER SERIES, SLC)

Version 1.5

Address: 28 Genting Lane, #09-03/4/5 Platinum 28, Singapore 349585

Tel : +65-6493 5035

Fax : +65-6493 5037

Website: <http://www.flexxon.com>

Email: flexxon@flexxon.com

ALL RIGHTS ARE STRICTLY RESERVED. ANY PORTION OF THIS PAPER SHALL NOT BE REPRODUCED, COPIED, OR TRANSLATED TO ANY OTHER FORMS WITHOUT PERMISSION FROM FLEXXON.

TABLE OF CONTENTS

1.	GENERAL DESCRIPTION	1
	1.1. Introduction	1
	1.2. Product Overview	2
2.	PRODUCT SPECIFICATIONS.....	3
	2.1. Performance.....	3
	2.2. Power.....	3
	2.3. TBW (Terabytes Written)	4
	2.4. MTBF	4
	2.5. Data Retention	4
3.	ENVIRONMENTAL SPECIFICATIONS.....	5
4.	ATA COMMANDS	6
5.	PIN ASSIGNMENT	9
6.	PHYSICAL DIMENSION	11
7.	ORDERING INFORMATION	12

1. GENERAL DESCRIPTION



1.1. Introduction

FLEXXON’s ACHIEVER mSATA has SATA III interface, and is fully compliant with standard mSATA form factor, known as JEDEC MO-300. It supports high performance, high reliability and low power management. It is suitable for heavy-loading or multi-tasking applications.

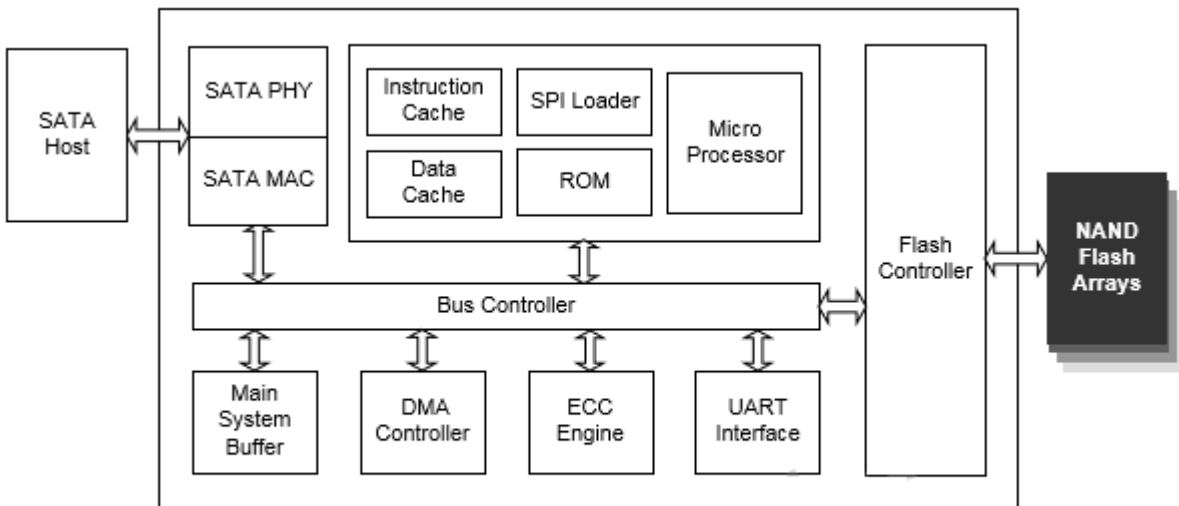

Figure 1-1 ACHIEVER mSATA Controller Block Diagram

FLEXXON

1.2. Product Overview

- ❖ **Flash**
 - SLC
- ❖ **Capacity**
 - 2GB up to 32GB
- ❖ **SATA Interface**
 - Compliant with SATA Revision 3.1
 - Compatible with SATA 1.5Gbps, 3Gbps and 6Gbps interface
- ❖ **ECC Scheme**
 - Up to 66 bits error in 1K Byte data.
- ❖ **UART Function**
- ❖ **GPIO**
- ❖ **Support SMART and TRIM commands**
- ❖ **Low Power Management**
- ❖ **Internal data shaping technique increase data endurance**
- ❖ **Global Wear Leveling Algorithm**
- ❖ **Hardware Write Protect (Optional)**
- ❖ **Temperature Range**
 - Operation (Silver): 0°C ~ 70°C
 - Operation (Diamond): -40°C ~ 85°C
 - Storage: -55°C ~ 85°C
- ❖ **RoHS Compliant**

2. PRODUCT SPECIFICATIONS



2.1. Performance

Table 2-1 Performance of ACHIEVER mSATA

Capacity	Sequential	
	Read (MB/s)	Write (MB/s)
2GB	38	34
4GB	42	36
8GB	84	77
16GB	169	149
32GB	172	156

NOTES:

1. The performance was measured using CrystalDiskMark with SATA 6Gbps Host.
2. Performance may differ according to flash configuration and platform.

2.2. Power

Table 2-2 Supply Voltage of ACHIEVER mSATA

Parameter	Parameter Specifications
Input Voltage	3.3V +/-5%

Table 2-3 Power Consumption of ACHIEVER mSATA

Parameter	Specifications(W)
Idle (max.)	0.372W
Active (max.)	1.425W

NOTE:

1. Power Consumption may differ from flash configuration and platform.



2.3. TBW (Terabytes Written)

Capacity	TBW
2GB	108
4GB	120
8GB	240
16GB	481
32GB	962

NOTES:

1. TBW may differ according to flash configuration and platform.
2. Samples were tested under JESD218A endurance test method and JESD219A endurance workloads specification.

2.4. MTBF

MTBF, an acronym for Mean Time Between Failures, is a measure of a device's reliability. Its value represents the average time between a repair and the next failure. The predicted result of FLEXON's ACHIEVER mSATA is more than 2 million hours.

2.5. Data Retention

- 10 years if > 90% life remaining (@25C)
- 1 year if < 10% life remaining (@25C)

3. ENVIRONMENTAL SPECIFICATIONS



Test Items	Test Conditions
Storage Temperature	-55°C ~ 95°C
Operating Temperature	Silver Grade: 0°C ~ 70°C Diamond Grade: -40°C ~ 85°C
Storage Humidity	Silver Grade: 40°C, 95% RH Diamond Grade: 55°C, 95% RH
Operating Humidity	Silver Grade: 40°C, 93% RH Diamond Grade: 55°C, 95% RH
Shock	1500G, Half Sin Pulse Duration 0.5ms
Vibration	80Hz ~ 2000Hz/20G, 20Hz ~ 80Hz/1.52mm, 3 axis/60min
Drop	80cm free fall, 6 face of each unit, 2 times each
Bending	≥50N, Hold 1 min/5 times
ESD	24°C, 49% RH, +/-4KV 25 times, Air +/-8KV 10 times

FLEXXON CONFIDENTIAL

Table 4-1 Supported ATA Command Set

# Command	Code	Protocol
General Feature Set		
Execute Drive Diagnostic	90h	Device diagnostic
Flush Cache	E7h	Non-data
Identify Device	ECh	PIO data-in
Initialize Drive Parameters	91h	Non-data
Read DMA	C8h	DMA
Read Log Ext	2Fh	PIO data-in
Read Multiple	C4h	PIO data-in
Read Sector(s)	20h	PIO data-in
Read Verify Sector(s)	40h or 41h	Non-data
Set Feature	EFh	Non-data
Set Multiple Mode	C6h	Non-data
Write DMA	CAh	DMA
Write Multiple	C5h	PIO data-out
Write Sector(s)	30h	PIO data-out
NOP	00h	Non-data
Read Buffer	E4h	PIO data-in
Write Buffer	E8h	PIO data-out
Power Management Feature Set		
Check Power Mode	E5h or 98h	Non-data
Idle	E3h or 97h	Non-data
Idle Immediate	E1h or 95h	Non-data
Sleep	E6h or 99h	Non-data
Standby	E2h or 96h	Non-data
Standby Immediate	E0h or 94h	Non-data

Security Mode Feature Set		
Security Set Password	F1h	PIO data-out
Security Unlock	F2h	PIO data-out
Security Erase Prepare	F3h	Non-data
Security Erase Unit	F4h	PIO data-out
Security Freeze Lock	F5h	Non-data
Security Disable Password	F6h	PIO data-out
SMART Feature Set		
SMART Disable Operations	B0h	Non-data
SMART Enable/Disable Autosave	B0h	Non-data
SMART Enable Operations	B0h	Non-data
SMART Execute Off-Line Immediate	B0h	Non-data
SMART Read Log	B0h	PIO data-in
SMART Read Data	B0h	PIO data-in
SMART Read Threshold	B0h	PIO data-in
SMART Return Status	B0h	Non-data
SMART Save Attribute Values	B0h	Non-data
SMART Write Log	B0h	PIO data-in
Host Protected Area Feature Set		
Read Native Max Address	F8h	Non-data
Set Max Address	F9h	Non-data
Set Max Set Password	F9h	PIO data-out
Set Max Lock	F9h	Non-data
Set Max Freeze Lock	F9h	Non-data
Set Max Unlock	F9h	PIO data-out
48-bit Address Feature Set		
Flush Cache Ext	EAh	Non-data
Read Sector(s) Ext	24h	PIO data-in
Read DMA Ext	25h	DMA
Read Multiple Ext	29h	PIO data-in
Read Native Max Address Ext	27h	Non-data
Read Verify Sector(s) Ext	42h	Non-data
Set Max Address Ext	37h	Non-data
Write DMA Ext	35h	DMA
Write Multiple Ext	39h	PIO data-out
Write Sector(s) Ext	34h	PIO data-out
NCQ Feature Set		
Read FPDMA Queued	60h	DMA Queued

Write FPDMA Queued	61h	DMA Queued
Others		
Data Set Management	06h	DMA
Seek	70h	Non-data

FLEXION CONFIDENTIAL

Table 5-1 Pin Assignment and Description of ACHIEVER mSATA

Pin #	mSATA Pin	Description
1	NC	No Connect
2	+3.3V	3.3V Source
3	NC	No Connect
4	GND	Ground
5	NC	No Connect
6	NC	No Connect
7	NC	No Connect
8	NC	No Connect
9	GND	Ground
10	NC	No Connect
11	NC	No Connect
12	NC	No Connect
13	NC	No Connect
14	NC	No Connect
15	GND	Ground
16	NC	No Connect
17	NC	No Connect
18	GND	Ground
19	NC	No Connect
20	NC	No Connect
21	GND	Ground
22	NC	No Connect
23	TXP (out)	Host Receiver Differential Signal Pair
24	+3.3V	3.3V Source
25	TXN (out)	Host Receiver Differential Signal Pair
26	GND	Ground
27	GND	Ground
28	NC	No Connect
29	GND	Ground
30	NC	No Connect
31	RXN (in)	Host Transmitter Differential Signal Pair
32	NC	No Connect

Pin #	mSATA Pin	Description
33	RXP (in)	Host Transmitter Differential Signal Pair
34	GND	Ground
35	GND	Ground
36	NC	No Connect
37	GND	Ground
38	NC	No Connect
39	+3.3V	3.3V Source
40	GND	Ground
41	+3.3V	3.3V Source
42	NC	No Connect
43	NC	No Connect
44	NC	No Connect
45	NC	Reserved pin
46	NC	No Connect
47	NC	No Connect
48	NC	No Connect
49	DAS	Device Activity Signal
50	GND	Ground
51	PD	Presence Detect (0 ohm to 220 ohm)
52	+3.3V	3.3V Source

6. PHYSICAL DIMENSION



Dimension (mm): 50.8 (L) x 29.85 (W) x 3.83 (H)

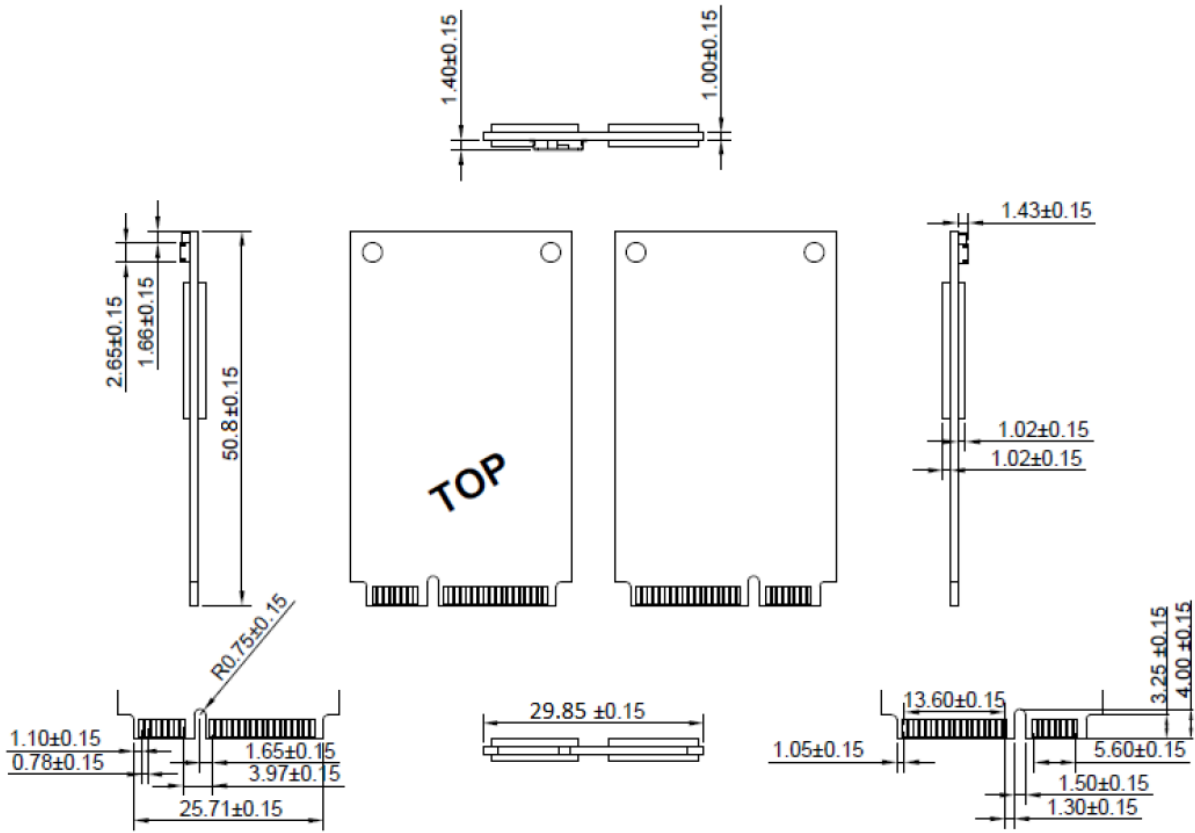

FLEXION

7. ORDERING INFORMATION



Capacity	MPN (Diamond Grade)	MPN (Silver Grade)
2GB	FSSE002GSE-M100	FSSE002GSS-M100
4GB	FSSE004GSE-M100	FSSE004GSS-M100
8GB	FSSE008GSE-M100	FSSE008GSS-M100
16GB	FSSE016GSE-M100	FSSE016GSS-M100
32GB	FSSE032GSE-M100	FSSE032GSS-M100
30GB	FSSE030GSE-M100	FSSE030GSS-M100

Hardware Write Protect

Capacity	MPN (Diamond Grade)	MPN (Silver Grade)
2GB	FSSE002GSE-M10K	FSSE002GSS-M10K
4GB	FSSE004GSE-M10K	FSSE004GSS-M10K
8GB	FSSE008GSE-M10K	FSSE008GSS-M10K
16GB	FSSE016GSE-M10K	FSSE016GSS-M10K
32GB	FSSE032GSE-M10K	FSSE032GSS-M10K
30GB	FSSE030GSE-M10K	FSSE030GSS-M10K

Hardware Write Protect and Conformal Coating

Capacity	MPN (Diamond Grade)	MPN (Silver Grade)
2GB	FSSE002GSE-M10F	FSSE002GSS-M10F
4GB	FSSE004GSE-M10F	FSSE004GSS-M10F
8GB	FSSE008GSE-M10F	FSSE008GSS-M10F
16GB	FSSE016GSE-M10F	FSSE016GSS-M10F
32GB	FSSE032GSE-M10F	FSSE032GSS-M10F
30GB	FSSE030GSE-M10F	FSSE030GSS-M10F

Revision History

Revision	Date	Description
1.0	2017/05	First release
1.1	2017/12	Update Product Overview
1.2	2018/05	Update Ordering information
1.3	2019/01	Update part number
1.4	2019/11	Update capacity
1.5	2020/04	Update capacity

FLEXXON CONFIDENTIAL