

EV Charging Socket

multicomp PRO

Application

- IEC 62196 Charging Station EVSE Socket Outlet is an essential component of an EV charging infrastructure and can be used in various applications to provide charging facilities to electric vehicles including: Public charging stations, Workplace charging stations, Residential charging stations as well as and Fleet charging scenarios.

**RoHS
Compliant**

Features

- Supports both single-phase and three-phase electric charging systems and is therefore suitable for Australia, Europe, India and Thailand.
- Designed with an actuator supporting security & access control.
- Provides low contact resistance and a minimum of 10,000 mating cycles.
- Ergonomic, rugged, unibody design provides optimal comfort and intuitive handling.
- Complies with IEC 62196 safety standards and TUV certified.
- Products passed 5000N drive over test.

Specification

EVSE Charging Socket	: 32A, Three-phase
Rated Current	: 32A
Rated Voltage	: 600V AC
IP (Mated)	: IP44
Force	: ≤100
Product Color	: Black
Max. Current	: 3.2A
Nominal Voltage	: 40ms<Time<200ms
IP (Actuator)	: IP54
Operating Temperature	: -30°C to 50°C
Main Materials	: PA66/PC/SUS
Flammability Rating	: UL 94V-0

Diagram

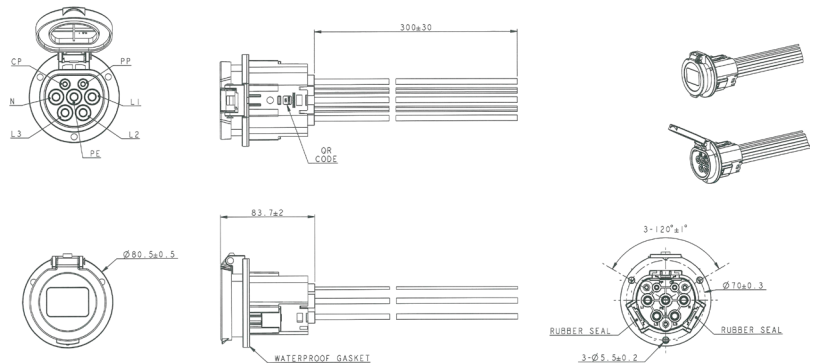

Note

- Connector Meets : IEC 62196-2-2016

	Current & Voltage	Wire Spec.	Insulation Colour
L1	32A 480V AC	6mm ²	Brown
L2			Black
L3			Gray
N			Blue
PE			Yellow/Green
CP	2A 30V DC	0.75mm ²	Red
PP			White

Part Number Table

Description	Part Number
EV Charging Socket, Type 2, Three Phase, 32A	MP013707

Dimensions : Millimetres

Important Notice : This data sheet and its contents (the "Information") belong to the members of the AVNET group of companies (the "Group") or are licensed to it. No licence is granted for the use of it other than for information purposes in connection with the products to which it relates. No licence of any intellectual property rights is granted. The Information is subject to change without notice and replaces all data sheets previously supplied. The Information supplied is believed to be accurate but the Group assumes no responsibility for its accuracy or completeness, any error in or omission from it or for any use made of it. Users of this data sheet should check for themselves the Information and the suitability of the products for their purpose and not make any assumptions based on information included or omitted. Liability for loss or damage resulting from any reliance on the Information or use of it (including liability resulting from negligence or where the Group was aware of the possibility of such loss or damage arising) is excluded. This will not operate to limit or restrict the Group's liability for death or personal injury resulting from its negligence. Multicomp Pro is the registered trademark of Premier Farnell Limited 2019.

Newark.com/multicomp-pro
Farnell.com/multicomp-pro
sg.element14.com/b/multicomp-pro

multicomp PRO