

1	2		3	4	5	6	7	8
Part Number	ØM	A Nom	B Nom	D Length	C			
RP0000380829	M2-0.4	1.2	3.8	6	1.9			
RP0000380842				8				
RP0000380838				10				
RP0000380844				12				
RP0000380845				16				
RP0000380902				20				
RP0000380904				25				
RP0000380906	M2.5-0.45	1.5	4.7	5	2.7			
RP0000380910				6				
RP0000380920				8				
RP0000380921				10				
RP0000380848				12				
RP0000380849				16				
RP0000380853				20				
RP0000380888	25							
RP0000380893	M3-0.5	1.65	5.5	5	2.9			
RP0000380899				6				
RP0000380909				8				
RP0000380922				10				
RP0000380911				12				
RP0000380924				16				
RP0000380912				20				
RP0000380925	25							
RP0000380926	M4-0.7	2.7	8.4	6	4.6			
RP0000380936				8				
RP0000380941				10				
RP0000380943				12				
RP0000380947				16				
RP0000380948				20				
RP0000380923				25				
RP0000380956	M5-0.8	2.7	9.0	8	4.8			
RP0000380964				10				
RP0000380965				12				
RP0000380966				16				
RP0000380983				20				
RP0000380984				25				
RP0000380986				30				
RP0000380997	40							

REVISION	
A	INITIAL DRAWING 02.02.2024

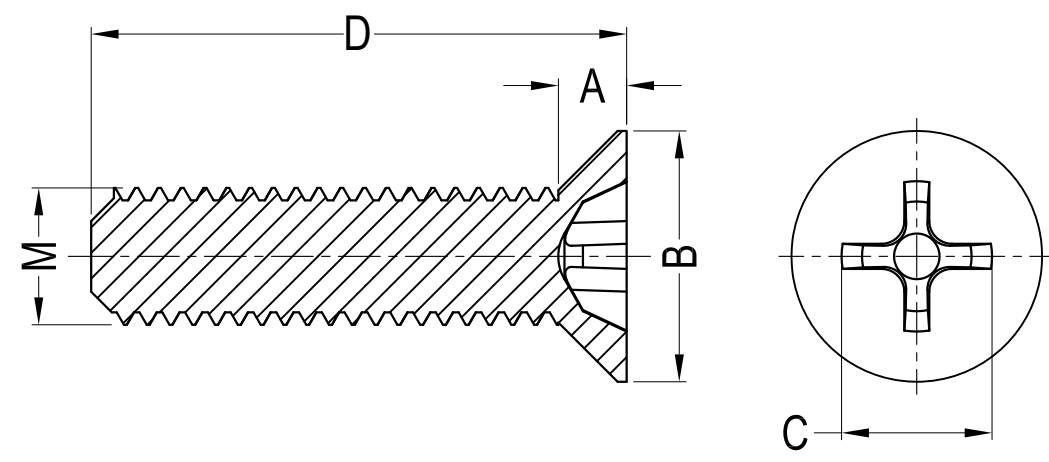

NOTES: DO NOT SCALE DRAWING

Male (M2) Torques: $\cong 0.06$ Nm;
 Male (M2.5) Torques: $\cong 0.08$ Nm;
 Male (M3) Torques: $\cong 0.13$ Nm;
 Male (M4) Torques: $\cong 0.3$ Nm;
 Male (M5) Torques: $\cong 0.58$ Nm;



UNLESS OTHERWISE SPECIFIED:
 DIMENSIONS ARE IN MM (MILLIMETERS).
 TOLERANCES: L \leq 4: ± 0.1
 4 < L \leq 15: ± 0.2
 15 < L \leq 50: ± 0.3
 50 < L \leq 100: ± 0.4

NAME	DATE
DRAWN Andrew Fletcher	02.02.24
CHK'D	
APPVD	

MATERIAL: NYLON 6,6 (UL94V-2)

HEAT TREATMENT: N/A

TITLE: Phillips Countersunk Head Machine Screw

DESIGN RIGHT. TR FASTENINGS LTD, 2024
 UNDER NO CIRCUMSTANCES MUST THIS DRAWING BE COPIED OR DISCLOSED WITHOUT FIRST OBTAINING WRITTEN AUTHORITY.

CUSTOMER PART NUMBER:
 N/A

FINISH/COLOUR: NATURAL

DRAWING NUMBER: N/A

A4