

Part Number	For Threads	A	B	C
RP0000080090	M2	4.9 +0/-0.36	2.5 +0.18/-0	0.35 ±0.05
RP0000080088	M2.5	6.5 +0/-0.36	2.7 +0.18/-0	0.50 ±0.05
RP0000080092	M3	7.0 +0/-0.36	3.2 +0.18/-0	0.50 ±0.05
RP0000080094	M4	9.0 +0/-0.36	4.3 +0.18/-0	0.80 ±0.10
RP0000080096	M5	10.0 +0/-0.36	5.3 +0.18/-0	1.00 ±0.10
RP0000080098	M6	12.0 +0/-0.43	6.4 +0.22/-0	1.60 ±0.20
RP0000380852	M8	16.0 +0/-0.43	8.4 +0.22/-0	1.60 ±0.20
RP0000380859	M10	20.0 +0/-0.52	10.5 +0.22/-0	2.00 ±0.20

REVISION	
A	INITIAL DRAWING 02.02.2024

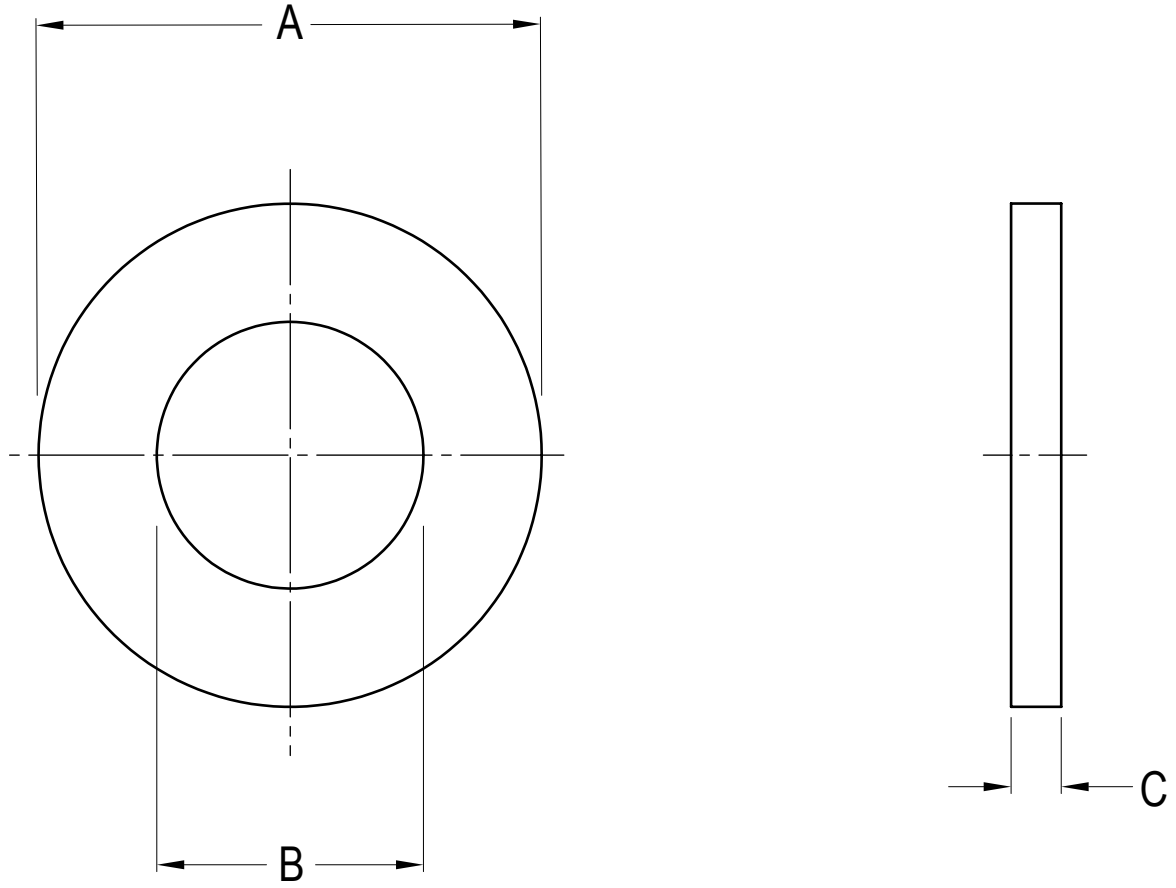

NOTES: DO NOT SCALE DRAWING



UNLESS OTHERWISE SPECIFIED:
DIMENSIONS ARE IN MM (MILLIMETERS).

	NAME	DATE
DRAWN	Andrew Fletcher	02.02.24
CHK'D		
APPV'D		

MATERIAL: NYLON 6,6 - UL94V-2

HEAT TREATMENT: N/A

TITLE: Metric Flat Washer (DIN 34815)

DESIGN RIGHT. TR FASTENINGS LTD, 2024
UNDER NO CIRCUMSTANCES MUST THIS DRAWING BE COPIED
OR DISCLOSED WITHOUT FIRST OBTAINING WRITTEN
AUTHORITY.

CUSTOMER PART NUMBER:
N/A

FINISH/COLOUR: NATURAL

DRAWING NUMBER: N/A

A4