

Part Name	Digital IR EVM KIT	Part No.	IMF059M00	Rev.	0.0
-----------	--------------------	----------	-----------	------	-----

## Digital output IR detector EVM Kit Manual



- 
- The information and design authority contained in this document is proprietary to Amphenol Advance Sensors and could be shared with any customers to promote.
  - The information and design authority contained in this document is proprietary to Customer and shall not be disclosed in whole or in part in any form or for any reason. You are required to contact with Amphenol Advance Sensors product management for more information or any help
  - The information and design authority contained in this document is generated by Amphenol Advance Sensors & Customer and shall not be disclosed in whole or in part in any form or for any reason. You are required to contact with Amphenol Advanced Sensors product management for more information or any help.

Part Name	Digital IR EVM KIT	Part No.	IMF059M00	Rev.	0.0
-----------	--------------------	----------	-----------	------	-----

### 1. Introduce

This document describes the ZTPD series digital output Evaluation Kit, including the hardware software, and its installation. The software is designed for Windows®-based operating systems to communicate with user’s computer, which functions as a master.

### 2. Overview

Evaluation Kit includes the following hardware components as below Fig 1.

- I2C communication board
- IR detector breakout board
- USB A to B cable
- Signal connect 4 wire cable
- \* Remark
- IR detector is not included at EVM Kit

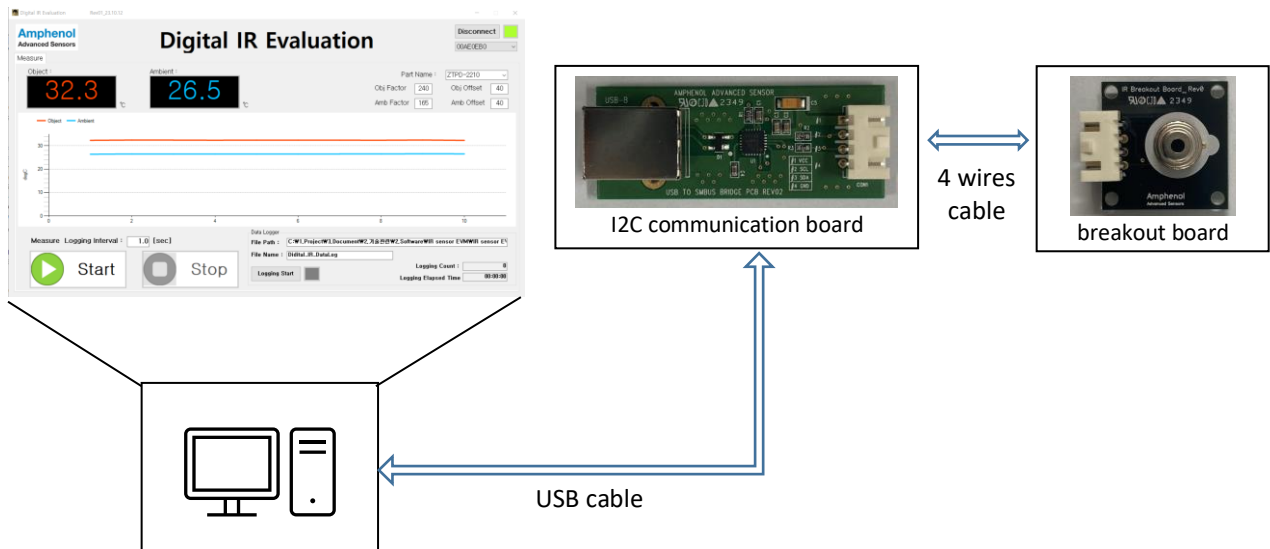

Fig. 1 Evaluation board setting Overview.

#### • Software operating procedure

- Downloading software
- Connect the USB cable(PC and I2C board) and 4 wire cable(I2C and breakout board)
- Enter folder and click ZTPD-2210\_EVM\_xxx\_xxx.exe
- Click connect button
- Click Start button

Part Name	Digital IR EVM KIT	Part No.	IMF059M00	Rev.	0.0
-----------	--------------------	----------	-----------	------	-----

### 3. Software GUI

Basic operating condition setting and display sensor measurement value.

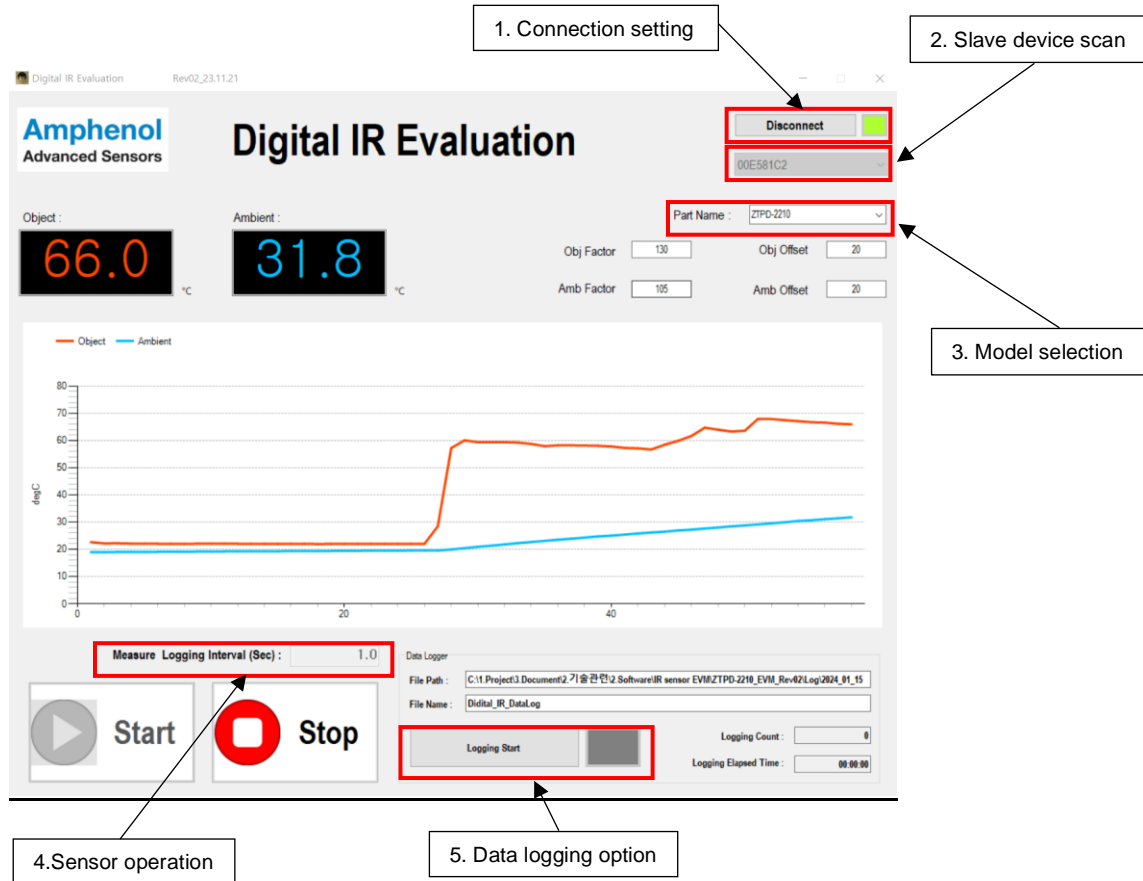

Fig. 2 Measurement Tab screen

Control Unit	Description
Connection setting	The button allows closing and opening the USB communication port.
Slave device scan	If the slave device address is not automatically displayed, check the device manually.
Model selection	Select specific ZTPD model
Measure Logging Interval	Sensor output temperature value display/logging interval setting
Logging Start	Measure data logging option(If you want to save data, click the button)
Data acquisition Start / Stop	Measurement start/stop setting

#### • Product selection

ZTPD series IR detector has different temperature ranged product, so evaluating sensors using EVM software, you must select the exact model you want to evaluate.

Part name	Object Temp. Range	Ambient Temp. Range	Remark
ZTPD-2210	-20°C ~ 100°C	-20°C ~ 85°C	Standard TO-39 package
ZTPD-2210TA	-20°C ~ 60°C	-20°C ~ 60°C	Standard TO-39 package
ZTPD-2210H	-40°C ~ 125°C	-20°C ~ 105°C	Narrow FOV TO-39 package

Part Name	Digital IR EVM KIT	Part No.	IMF059M00	Rev.	0.0
-----------	--------------------	----------	-----------	------	-----

#### 4. Logging data

Evaluation software provide sensor measurement data in csv file format.

Below is sensor logged data example.

Time	Object Temperature [degC]	Ambient Temperature [degC]
[2023-11-01 13:17:09.338]	25.6	27.8
[2023-11-01 13:17:10.345]	25.6	27.8
[2023-11-01 13:17:11.337]	25.4	27.8
[2023-11-01 13:17:12.345]	25.6	27.8
[2023-11-01 13:17:13.335]	25.2	27.8
[2023-11-01 13:17:14.344]	25.2	27.8
[2023-11-01 13:17:15.339]	25.3	27.8
[2023-11-01 13:17:16.333]	25.1	27.8
[2023-11-01 13:17:17.339]	25.4	27.8
[2023-11-01 13:17:18.338]	25.4	27.8
[2023-11-01 13:17:19.342]	25.4	27.8
[2023-11-01 13:17:20.336]	25.5	27.8
[2023-11-01 13:17:21.344]	26.8	27.8
[2023-11-01 13:17:22.332]	29.2	27.8
[2023-11-01 13:17:23.347]	27.8	27.7
[2023-11-01 13:17:24.332]	27.4	27.8
[2023-11-01 13:17:25.336]	27.4	27.8
[2023-11-01 13:17:26.344]	27.5	27.8
[2023-11-01 13:17:27.340]	27	27.8

#### Revision

Version	Changes	Remark	Date
00		Initial release	15 Jan 2024