

ECP40 Series



- Low Profile Design
- Ultra Compact Size from 3" x 2" x 0.9"
- IT & Medical Approvals
- Single, Dual and Triple Output
- <0.3 W No Load Input Power
- Peak Load Capability
- 3 Year Warranty

Specification

Input

Input Voltage	• 85-264 VAC
Input Frequency	• 47-63 Hz
Input Current	• 0.85 A max at 115 VAC
Inrush Current	• 65 A max at 230 VAC
Power Factor	• Conforms to EN61000-3-2, Class A
No Load Input Power	• <0.3 W
Earth Leakage Current	• <250 μ A at 264 VAC, 60 Hz
Input Protection	• Internal T2 A/250 V fuse in both line and neutral

Output

Output Voltage	• See table
Initial Set Accuracy	• Single output: $\pm 1\%$ at 60% load, Multiple output: $\pm 1\%$ on V1, $\pm 5\%$ on V2, V3 at 60% load
Minimum Load	• 10% minimum load required on V1 & V2 of multi output versions
Start Up Delay	• 1.3 s max
Start Up Rise Time	• 15 ms typical
Hold Up Time	• 10 ms min at full load at 115 VAC
Line Regulation	• $\pm 0.5\%$ max
Load Regulation	• V1 & V3: $\pm 2\%$, V2: $\pm 4\%$, see note 3
Cross Regulation	• V2: 5%, 10-100% load change on V1
Transient Response	• 4% max deviation, recovering to less than 1% within 500 μ s for 50% step load change at 1 A/ μ s
Ripple & Noise	• 1% pk-pk, measured with 20 MHz bandwidth
Overvoltage Protection	• 110-140% of nominal output voltage on V1 only, recycle input to reset
Overload Protection	• Single output: 140-160% of nominal power Multiple output: 120-150% of nominal power on V1 and V2 only
Short Circuit Protection	• Trip and restart (Hiccup mode)
Temperature Coefficient	• $\pm 0.02\%/^{\circ}\text{C}$ max

General

Efficiency	• See tables
Isolation	• 4000 VAC Input to Output 1500 VAC Input to Ground 500 VAC Output to Ground
Switching Frequency	• 40-130 kHz variable
MTBF	• >400 kHrs to MIL-HDBK-217F at 25 $^{\circ}\text{C}$, GB

Environmental

Operating Temperature	• -10 $^{\circ}\text{C}$ to +70 $^{\circ}\text{C}$, derate from 100% load at 50 $^{\circ}\text{C}$ to 50% load at 70 $^{\circ}\text{C}$
Cooling	• Natural convection
Operating Humidity	• 5% to 95% RH, non condensing
Storage Temperature	• -40 $^{\circ}\text{C}$ to +85 $^{\circ}\text{C}$
Shock	• 30 g pk, half sine, 6 axes
Vibration	• 2 g rms, 5 Hz to 500 kHz, 3 axes

EMC & Safety

Emissions	• EN55022, level B conducted & radiated
Harmonic Currents	• EN61000-3-2, class A
Voltage Flicker	• EN61000-3-3
ESD Immunity	• EN61000-4-2, ± 4 kV indirect contact, Perf Criteria A
Radiated Immunity	• EN61000-4-3, 3 V/m, Perf Criteria A
EFT / Burst	• EN61000-4-4, level 2 Perf Criteria A
Surge	• EN61000-4-5, level 2 Perf Criteria A
Conducted Immunity	• EN61000-4-6, 3 V Perf Criteria A
Dips & Interruptions	• EN61000-4-11, 30% 10 ms, 60% 100 ms, 100% 5000 ms, Perf Criteria A, B, B
Safety Approvals	• EN60950-1, cUL60950, IEC60950-1, EN60601-1, cUL60601-1, IEC60601-1

Models and Ratings

Output Power	Output 1			Output 2			Output 3		Efficiency ⁽²⁾	Model Number
	Voltage	Current	Peak ⁽¹⁾	Voltage	Current	Peak ⁽¹⁾	Voltage	Current		
30 W	5.0 VDC	6.00 A	7.80 A						82%	ECP40US05
40 W	12.0 VDC	3.34 A	4.34 A						89%	ECP40US12
40 W	15.0 VDC	2.67 A	3.47 A						89%	ECP40US15
40 W	18.0 VDC	2.22 A	2.89 A						90%	ECP40US18
40 W	24.0 VDC	1.67 A	2.17 A						90%	ECP40US24
40 W	30.0 VDC	1.34 A	1.74 A						91%	ECP40US30
40 W	48.0 VDC	0.84 A	1.09 A						92%	ECP40US48
40 W	5.0 VDC	5.00 A	7.80 A	12.0 VDC	2.0 A	2.60 A			89%	ECP40UD01
40 W	5.0 VDC	5.00 A	7.80 A	15.0 VDC	1.5 A	1.95 A			90%	ECP40UD02
40 W	5.0 VDC	5.00 A	7.80 A	24.0 VDC	1.0 A	1.30 A			90%	ECP40UD03
40 W	5.0 VDC	5.00 A	7.80 A	12.0 VDC	2.0 A	2.60 A	-12.0 VDC	0.5 A	89%	ECP40UT01
40 W	5.0 VDC	5.00 A	7.80 A	15.0 VDC	1.5 A	1.95 A	-15.0 VDC	0.5 A	90%	ECP40UT02
40 W	5.0 VDC	5.00 A	7.80 A	24.0 VDC	1.0 A	1.30 A	+12.0 VDC	0.5 A	90%	ECP40UT03
40 W	5.0 VDC	5.00 A	7.80 A	24.0 VDC	1.0 A	1.30 A	-12.0 VDC	0.5 A	90%	ECP40UT04

Notes

1. Peak load lasting <30 s with a maximum duty cycle of 10%, average output power not to exceed nominal.
2. Typical efficiency at 230 VAC and full load at 25 °C.
3. For multiple output units, load regulation is given for load change of 10% to 100% with other outputs set to 60% adjustment load.

Mechanical Details

ECP40USXX

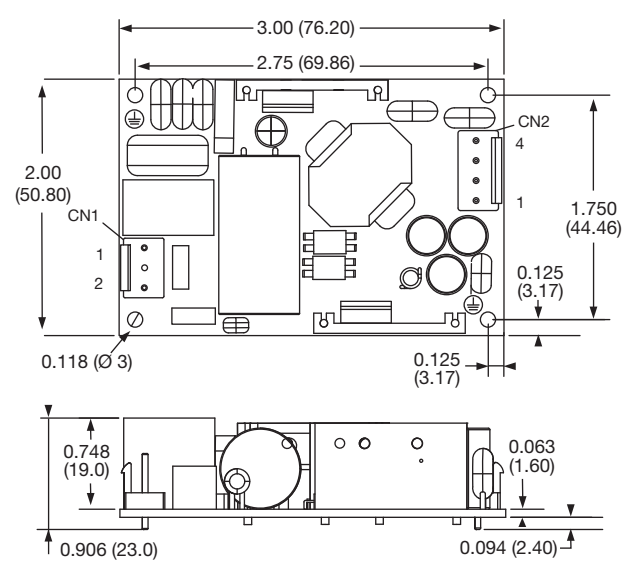

ECP40UDXX / ECP40UTXX

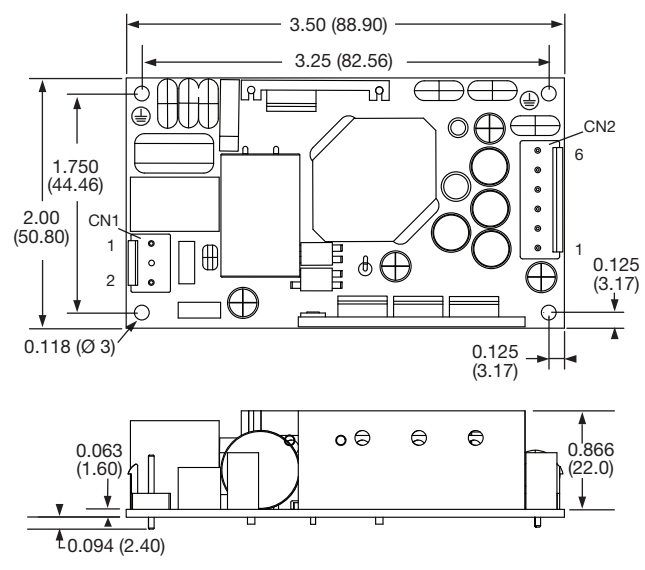

Input Connector CN1	
Pin 1	Line
Pin 2	Neutral

CN1 mates with JST housing VHR-2N and JST Series SVH-21T-P1.1 crimp terminals.

Output Connector CN2	
Pin 1	- Vout
Pin 2	- Vout
Pin 3	+ Vout
Pin 4	+ Vout

CN1 mates with JST housing VHR-4N and JST Series SVH-21T-P1.1 crimp terminals.

Input Connector CN1	
Pin 1	Line
Pin 2	Neutral

CN1 mates with JST housing VHR-2N and JST Series SVH-21T-P1.1 crimp terminals.

Output Connector CN2	
Pin 1	V3
Pin 2	RTN
Pin 3	RTN
Pin 4	V1
Pin 5	V1
Pin 6	V2

CN1 mates with JST housing VHR-6N and JST Series SVH-21T-P1.1 crimp terminals.

Notes

1. All measurements are in inches (mm).
2. Weight: 0.09 lbs (40 g) approx.

