



Telemecanique

LA9-D11502



SQUARE D

LA9-D11569 / D11570 / D11571

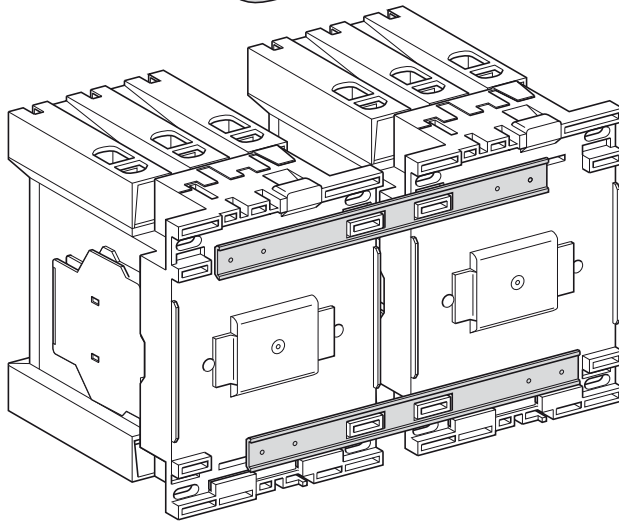
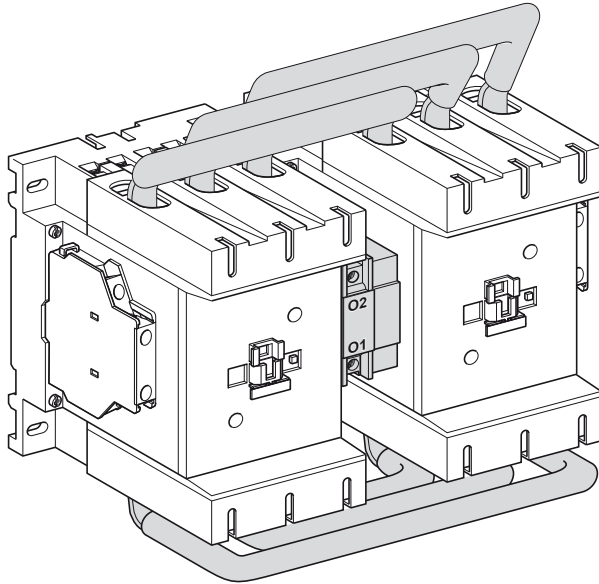

W9 1511302 0121 A03

Schneider
 **Electric**

LA9-D11502, LA9-D11569 / D11570 / D11571

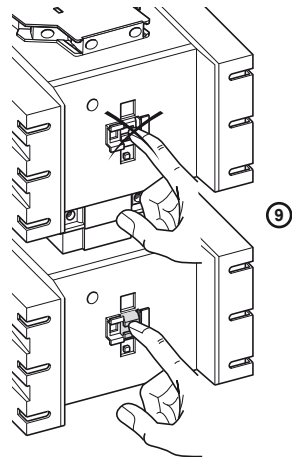
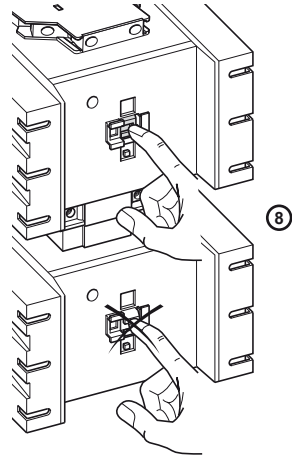
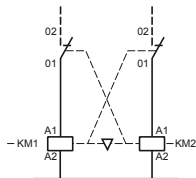
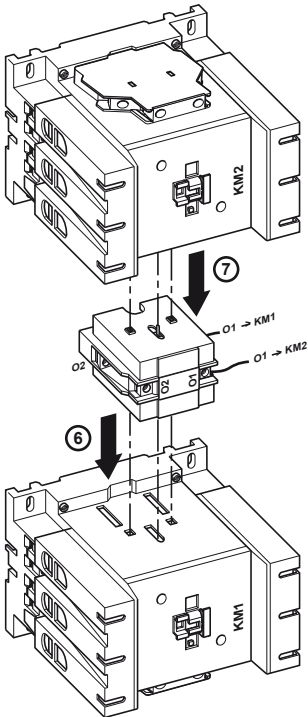
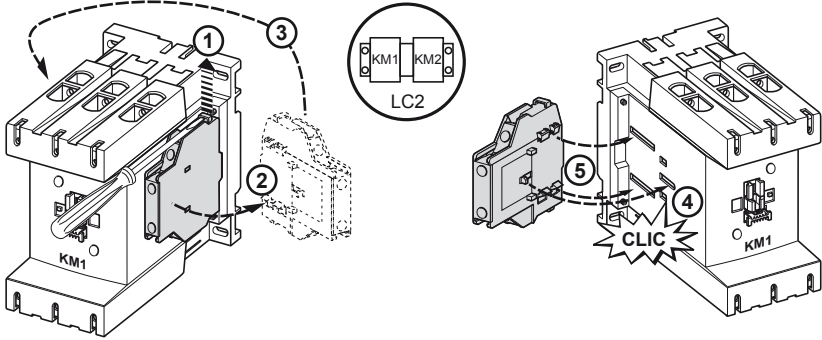

LA9-D11502, LA9-D11569 / D11570 / D11571

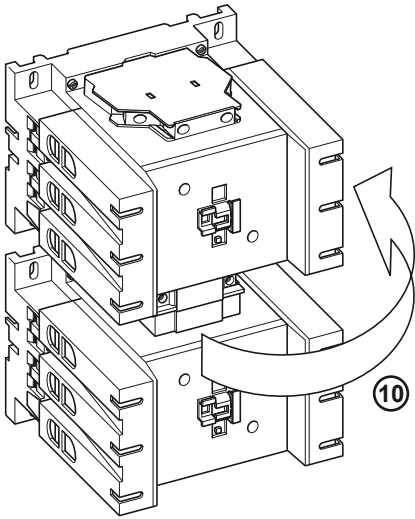

10

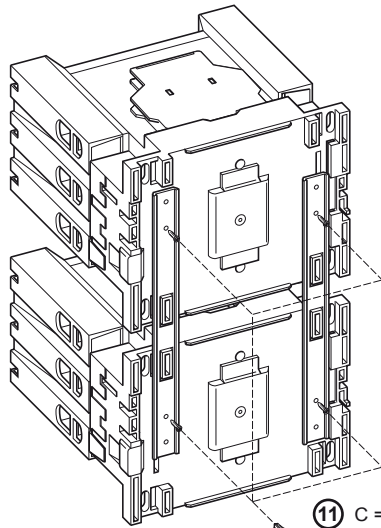

11 C = 0,9 N.m
C = 7.7 lb.in

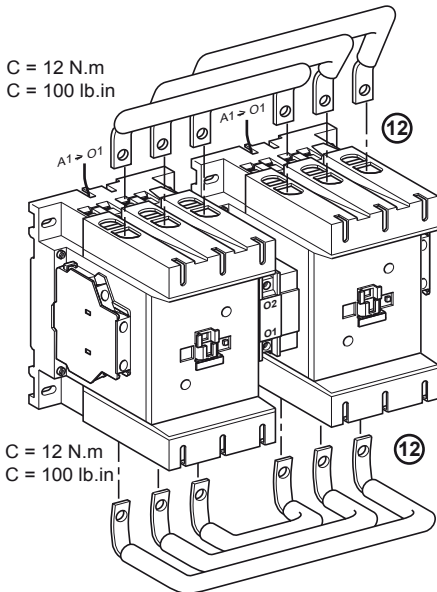

C = 12 N.m
C = 100 lb.in

12

C = 12 N.m
C = 100 lb.in

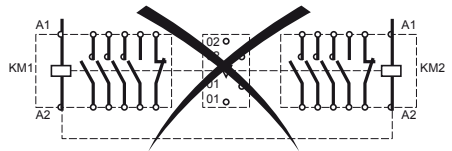
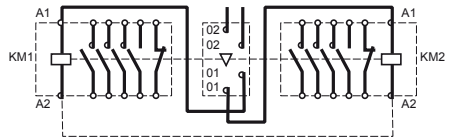

LA9-D11502, LA9-D11569 / D11570 / D11571

12 LA9-D11569

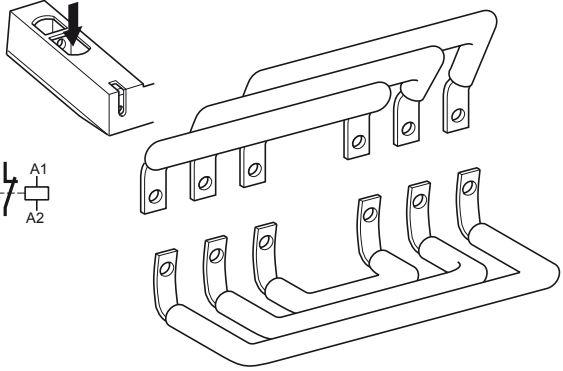
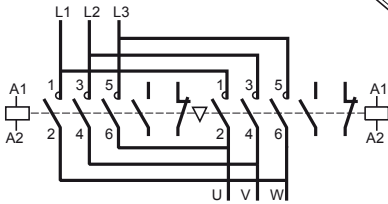

12 LA9-D11570

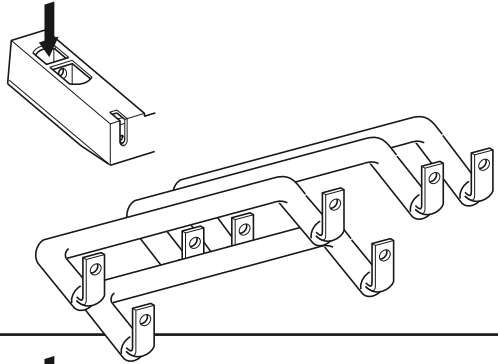
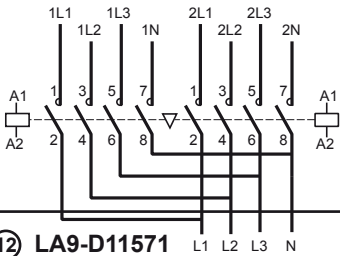

12 LA9-D11571

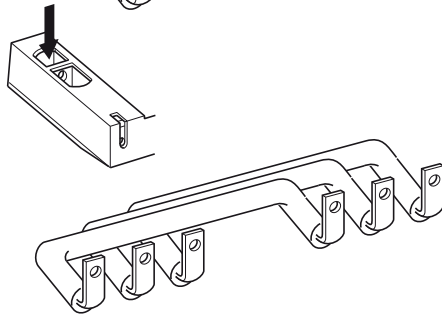
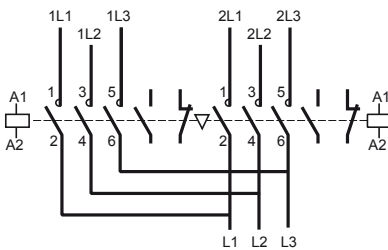

⚠ DANGER / PELIGRO / DANGER / ОПАСНО

HAZARDOUS VOLTAGE
Disconnect all power before servicing equipment. Electric shock will result in death or serious injury

TENSION PELIGROSA
Desenergice el equipo antes de realizarte servicio. Una descarga eléctrica podrá causar la muerte o lesiones serias.

TENSION DANGEREUSE
Coupez l'alimentation avant de travailler sur cet appareil. Une électrocution entrainera la mort ou des blessures graves.

ОПАСНОЕ НАПРЯЖЕНИЕ!
Перед обслуживанием или ремонтом убедитесь, что питание отключено. Поражение электрическим током может привести к смерти или тяжелым травмам