

## Solid-Electrolyte TANTALEX<sup>®</sup> Capacitors Hermetically-Sealed, Axial-Lead



### FEATURES

- Terminations: Tin/lead (SnPb), 100 % Tin (RoHS compliant)  Available
- These high performance, hermetically-sealed TANTALEX<sup>®</sup> capacitors have set the standard for solid-electrolyte tantalum capacitors for more than three decades. **RoHS\* COMPLIANT**
- High capacitance, low DCL, low dissipation factor and exceptional operating stability.
- Performance and reliability have been proven in commercial, industrial and military applications.
- Available in four case codes and capacitors are supplied with plastic-film insulation.
- Terminals are solid, tinned nickel wire leads.
- The Military equivalent to the 150D is the CSR13 which is qualified to MIL-C-39003/01.
- Compliant to RoHS directive 2002/95/EC

### PERFORMANCE CHARACTERISTICS

**Operating Temperature:** - 55 °C to + 85 °C  
(To + 125 °C with voltage derating)

**Capacitance Tolerance:** At 120 Hz, + 25 °C. ± 20 %, ± 10 % standard. ± 5 % available as special.

**Dissipation Factor:** At 120 Hz, + 25 °C. Dissipation factor, as determined from the expression  $2\pi fRC$ , shall not exceed the values listed in the Standard Ratings Tables.

**DC Leakage Current (DCL Max.):**

**At + 25 °C:** Leakage current shall not exceed the values listed in the Standard Ratings Tables.

**At + 85 °C:** Leakage current shall not exceed 10 times the values listed in the Standard Ratings Tables.

**At +125 °C:** Leakage shall not exceed 15 times the values listed in the Standard Ratings Tables.

**Life Test:** Capacitors shall withstand rated DC voltage applied at + 85 °C for 2000 h or derated DC voltage applied at + 125 °C for 1000 h

Following the life test:

1. DCL shall not exceed 125 % of the initial requirement
2. Dissipation Factor shall meet the initial requirement
3. Change in capacitance shall not exceed ± 5 %

### DIMENSIONS in inches [millimeters]

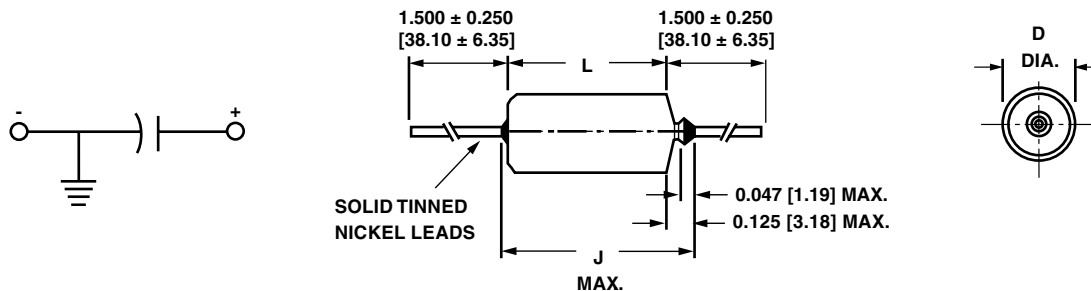

CASE CODE	WITH INSULATING SLEEVE <sup>(1)</sup>		J (MAXIMUM)	LEAD SIZE	
	D	L		AWG NO.	NOMINAL DIAMETER
A	0.135 ± 0.016 [3.43 ± 0.41]	0.286 ± 0.031 [7.26 ± 0.79]	0.422 [10.720]	24	0.020 [0.51]
B	0.185 ± 0.016 [4.70 ± 0.41]	0.474 ± 0.031 [12.04 ± 0.79]	0.610 [15.490]	24	0.020 [0.51]
R	0.289 ± 0.016 [7.34 ± 0.41]	0.686 ± 0.031 [17.42 ± 0.79]	0.822 [20.880]	22	0.025 [0.64]
S	0.351 ± 0.016 [8.92 ± 0.41]	0.786 ± 0.031 [19.96 ± 0.79]	0.922 [23.420]	22	0.025 [0.64]

**Note**

<sup>(1)</sup> When a shrink-fitted insulation is used, it shall lap over the ends of the capacitor body

\* Pb containing terminations are not RoHS compliant, exemptions may apply



Solid-Electrolyte TANTALEX® Capacitors  
Hermetically-Sealed, Axial-Lead

Vishay Sprague

ORDERING INFORMATION							
150D	224	X0	006	A	2	T	E3
MODEL	CAPACITANCE	CAPACITANCE TOLERANCE	DC VOLTAGE RATING	CASE CODE	STYLE NUMBER	PACKAGING	ROHS COMPLIANT
	This is expressed in picofarads. The first two digits are the significant figures. The third is the number of zeros to follow.	X0 = ± 20 % X9 = ± 10 % *X5 = ± 5 % *Special Order	This is expressed in volts. To complete the three-digit block, zeros precede the voltage rating.	See Ratings and Case Codes Table.	0 = No Sleeve 2 = Insulated sleeve	B = Bulk T = Tape and Reel	E3 = 100 % Tin termination (RoHS compliant) Blank = SnPb termination

STANDARD RATINGS						
CAPACITANCE (µF)	CASE CODE	PART NUMBER CAP. TOL. ± 20 %	PART NUMBER CAP. TOL. ± 10 %	MAX. DCL AT + 25 °C (µA)	MAX. DF AT + 25 °C 120 Hz (%)	
<b>6 WVDC AT + 85 °C, SURGE = 8 V . . . 4 WVDC AT + 125 °C, SURGE = 5 V</b>						
0.22	A	150D224X0006A2	150D224X9006A2	0.5	2	
0.27	A	-	150D274X9006A2	0.5	2	
0.33	A	150D334X0006A2	150D334X9006A2	0.5	2	
0.39	A	-	150D394X9006A2	0.5	2	
0.47	A	150D474X0006A2	150D474X9006A2	0.5	2	
0.56	A	-	150D564X9006A2	0.5	2	
0.68	A	150D684X0006A2	150D684X9006A2	0.5	2	
0.82	A	-	150D824X9006A2	0.5	2	
1.0	A	150D105X0006A2	150D105X9006A2	0.5	2	
1.2	A	-	150D125X9006A2	0.5	4	
1.5	A	150D155X0006A2	150D155X9006A2	0.5	4	
1.8	A	-	150D185X9006A2	0.5	4	
2.2	A	150D225X0006A2	150D225X9006A2	0.5	4	
2.7	A	-	150D275X9006A2	0.5	4	
3.3	A	150D335X0006A2	150D335X9006A2	0.5	4	
3.9	A	-	150D395X9006A2	0.5	4	
4.7	A	150D475X0006A2	150D475X9006A2	0.5	4	
5.6	A	-	150D565X9006A2	0.5	4	
6.8	A	150D685X0006A2	150D685X9006A2	0.5	6	
8.2	B	-	150D825X9006B2	0.5	6	
10.0	B	150D106X0006B2	150D106X9006B2	0.5	6	
12.0	B	-	150D126X9006B2	0.5	6	
15.0	B	150D156X0006B2	150D156X9006B2	1.0	6	
18.0	B	-	150D186X9006B2	1.0	6	
22.0	B	150D226X0006B2	150D226X9006B2	1.0	6	
27.0	B	-	150D276X9006B2	1.0	6	
33.0	B	150D336X0006B2	150D336X9006B2	1.0	6	
39.0	B	-	150D396X9006B2	1.0	6	
47.0	B	150D476X0006B2	150D476X9006B2	2.0	6	
56.0	B	-	150D566X9006B2	2.0	6	
68.0	R	150D686X0006R2	150D686X9006R2	3.0	6	
82.0	R	-	150D826X9006R2	3.0	6	
100.0	R	150D107X0006R2	150D107X9006R2	3.0	6	
120.0	R	150D127X0006R2	150D127X9006R2	3.0	6	
150.0	R	150D157X0006R2	150D157X9006R2	6.0	6	
180.0	R	150D187X0006R2	150D187X9006R2	6.0	6	
220.0	S	150D227X0006S2	150D227X9006S2	6.0	8	
270.0	S	150D277X0006S2	150D277X9006S2	6.0	8	
330.0	S	150D337X0006S2	150D337X9006S2	10.0	8	

**STANDARD RATINGS**

CAPACITANCE (μF)	CASE CODE	PART NUMBER (1) CAP. TOL. ± 20 %	PART NUMBER (1) CAP. TOL. ± 10 %	Max. DCL AT + 25 °C (μA)	Max. DF AT + 25 °C 120 Hz (%)
<b>10 WVDC AT + 85 °C, SURGE = 13 V . . . 7 WVDC AT + 125 °C, SURGE = 9 V</b>					
0.22	A	150D224X0010A2	150D224X9010A2	0.5	2
0.27	A	-	150D274X9010A2	0.5	2
0.33	A	150D334X0010A2	150D334X9010A2	0.5	2
0.39	A	-	150D394X9010A2	0.5	2
0.47	A	150D474X0010A2	150D474X9010A2	0.5	2
0.56	A	-	150D564X9010A2	0.5	2
0.68	A	150D684X0010A2	150D684X9010A2	0.5	2
0.82	A	-	150D824X9010A2	0.5	2
1.0	A	150D105X0010A2	150D105X9010A2	0.5	2
1.2	A	-	150D125X9010A2	0.5	4
1.5	A	150D155X0010A2	150D155X9010A2	0.5	4
1.8	A	-	150D185X9010A2	0.5	4
2.2	A	150D225X0010A2	150D225X9010A2	0.5	4
2.7	A	-	150D275X9010A2	0.5	4
3.3	A	150D335X0010A2	150D335X9010A2	0.5	4
3.9	A	-	150D395X9010A2	0.5	4
4.7	A	150D475X0010A2	150D475X9010A2	0.5	4
5.6	B	-	150D565X9010B2	0.5	4
6.8	B	150D685X0010B2	150D685X9010B2	1.0	6
8.2	B	-	150D825X9010B2	1.0	6
10.0	B	150D106X0010B2	150D106X9010B2	1.0	6
12.0	B	-	150D126X9010B2	1.0	6
15.0	B	150D156X0010B2	150D156X9010B2	1.0	6
18.0	B	-	150D186X9010B2	1.0	6
22.0	B	150D226X0010B2	150D226X9010B2	2.0	6
27.0	B	-	150D276X9010B2	2.0	6
33.0	B	150D336X0010B2	150D336X9010B2	2.0	6
39.0	B	-	150D396X9010B2	2.0	6
47.0	R	150D476X0010R2	150D476X9010R2	3.0	6
56.0	R	-	150D566X9010R2	3.0	6
68.0	R	150D686X0010R2	150D686X9010R2	3.0	6
82.0	R	-	150D826X9010R2	3.0	6
100.0	R	150D107X0010R2	150D107X9010R2	6.0	6
120.0	R	150D127X0010R2	150D127X9010R2	6.0	6
150.0	S	150D157X0010S2	150D157X9010S2	10.0	6
180.0	S	150D187X0010S2	150D187X9010S2	10.0	6
220.0	S	150D227X0010S2	150D227X9010S2	10.0	8
<b>15 WVDC AT + 85 °C, SURGE = 20 V . . . 10 WVDC AT + 125 °C, SURGE = 12 V</b>					
0.22	A	150D224X0015A2	150D224X9015A2	0.5	2
0.27	A	-	150D274X9015A2	0.5	2
0.33	A	150D334X0015A2	150D334X9015A2	0.5	2
0.39	A	-	150D394X9015A2	0.5	2
0.47	A	150D474X0015A2	150D474X9015A2	0.5	2
0.56	A	-	150D564X9015A2	0.5	2
0.68	A	150D684X0015A2	150D684X9015A2	0.5	2
0.82	A	-	150D824X9015A2	0.5	2
1.0	A	150D105X0015A2	150D105X9015A2	0.5	2
1.2	A	-	150D125X9015A2	0.5	4
1.5	A	150D155X0015A2	150D155X9015A2	0.5	4
1.8	A	-	150D185X9015A2	0.5	4
2.2	A	150D225X0015A2	150D225X9015A2	0.5	4
2.7	A	-	150D275X9015A2	0.5	4
3.3	A	150D335X0015A2	150D335X9015A2	0.5	4
3.9	B	-	150D395X9015B2	0.5	4
4.7	B	150D475X0015B2	150D475X9015B2	1.0	4

**Note**

(1) Insert capacitance tolerance code "X5" for ± 5 % units (special order)



Solid-Electrolyte TANTALEX® Capacitors  
Hermetically-Sealed, Axial-Lead

Vishay Sprague

<b>STANDARD RATINGS</b>					
CAPACITANCE (µF)	CASE CODE	PART NUMBER (1) CAP. TOL. ± 20 %	PART NUMBER (1) CAP. TOL. ± 10 %	Max. DCL AT + 25 °C (µA)	Max. DF AT + 25 °C 120 Hz (%)
<b>15 WVDC AT + 85 °C, SURGE = 20 V . . . 10 WVDC AT + 125 °C, SURGE = 12 V</b>					
5.6	B	-	150D565X9015B2	1.0	4
6.8	B	150D685X0015B2	150D685X9015B2	1.0	6
8.2	B	-	150D825X9015B2	1.0	6
10.0	B	150D106X0015B2	150D106X9015B2	1.0	6
12.0	B	-	150D126X9015B2	1.0	6
15.0	B	150D156X0015B2	150D156X9015B2	2.0	6
18.0	B	-	150D186X9015B2	2.0	6
22.0	B	150D226X0015B2	150D226X9015B2	3.0	6
27.0	R	-	150D276X9015R2	3.0	6
33.0	R	150D336X0015R2	150D336X9015R2	3.0	6
39.0	R	-	150D396X9015R2	3.0	6
47.0	R	150D476X0015R2	150D476X9015R2	6.0	6
56.0	R	-	150D566X9015R2	6.0	6
68.0	R	150D686X0015R2	150D686X9015R2	6.0	6
82.0	S	-	150D826X9015S2	6.0	6
100.0	S	150D107X0015S2	150D107X9015S2	6.0	6
120.0	S	150D127X0015S2	150D127X9015S2	6.0	6
150.0	S	150D157X0015S2	150D157X9015S2	10.0	6
<b>20 WVDC AT + 85 °C, SURGE = 26 V . . . 13 WVDC AT + 125 °C, SURGE = 16 V</b>					
0.027	A	-	150D273X9020A2	0.1	2
0.033	A	150D333X0020A2	150D333X9020A2	0.1	2
0.039	A	-	150D393X9020A2	0.1	2
0.047	A	150D473X0020A2	150D473X9020A2	0.1	2
0.056	A	-	150D563X9020A2	0.1	2
0.068	A	150D683X0020A2	150D683X9020A2	0.1	2
0.082	A	-	150D823X9020A2	0.1	2
0.10	A	150D104X0020A2	150D104X9020A2	0.5	2
0.12	A	-	150D124X9020A2	0.5	2
0.15	A	150D154X0020A2	150D154X9020A2	0.5	2
0.18	A	-	150D184X9020A2	0.5	2
0.22	A	150D224X0020A2	150D224X9020A2	0.5	2
0.27	A	-	150D274X9020A2	0.5	2
0.33	A	150D334X0020A2	150D334X9020A2	0.5	2
0.39	A	-	150D394X9020A2	0.5	2
0.47	A	150D474X0020A2	150D474X9020A2	0.5	2
0.56	A	-	150D564X9020A2	0.5	2
0.68	A	150D684X0020A2	150D684X9020A2	0.5	2
0.82	A	-	150D824X9020A2	0.5	2
1.0	A	150D105X0020A2	150D105X9020A2	0.5	2
1.2	A	-	150D125X9020A2	0.5	4
1.5	A	150D155X0020A2	150D155X9020A2	0.5	4
1.8	A	-	150D185X9020A2	0.5	4
2.2	A	150D225X0020A2	150D225X9020A2	0.5	4
2.7	B	-	150D275X9020B2	0.5	4
3.3	B	150D335X0020B2	150D335X9020B2	0.5	4
3.9	B	-	150D395X9020B2	1.0	4
4.7	B	150D475X0020B2	150D475X9020B2	1.0	4
5.6	B	-	150D565X9020B2	1.0	4
6.8	B	150D685X0020B2	150D685X9020B2	1.0	6
8.2	B	-	150D825X9020B2	1.0	6
10.0	B	150D106X0020B2	150D106X9020B2	1.0	6
12.0	B	-	150D126X9020B2	1.0	6
15.0	B	150D156X0020B2	150D156X9020B2	2.0	6

**Note**

(1) Insert capacitance tolerance code "X5" for ± 5 % units (special order)

<b>STANDARD RATINGS</b>					
CAPACITANCE (μF)	CASE CODE	PART NUMBER (1) CAP. TOL. ± 20 %	PART NUMBER (1) CAP. TOL. ± 10 %	Max. DCL AT + 25 °C (μA)	Max. DF AT + 25 °C 120 Hz (%)
<b>20 WVDC AT + 85 °C, SURGE = 26 V . . . 13 WVDC AT + 125 °C, SURGE = 16 V</b>					
18.0	R	-	150D186X9020R2	3.0	6
22.0	R	150D226X0020R2	150D226X9020R2	3.0	6
27.0	R	-	150D276X9020R2	3.0	6
33.0	R	150D336X0020R2	150D336X9020R2	3.0	6
39.0	R	-	150D396X9020R2	3.0	6
47.0	R	150D476X0020R2	150D476X9020R2	6.0	6
56.0	S	-	150D566X9020S2	6.0	6
68.0	S	150D686X0020S2	150D686X9020S2	6.0	6
82.0	S	-	150D826X9020S2	6.0	6
100.0	S	150D107X0020S2	150D107X9020S2	10.0	6
<b>35 WVDC AT + 85 °C, SURGE = 46 V . . . 23 WVDC AT + 125 °C, SURGE = 28 V</b>					
0.027	A	-	150D273X9035A2	0.1	2
0.033	A	150D333X0035A2	150D333X9035A2	0.1	2
0.039	A	-	150D393X9035A2	0.1	2
0.047	A	150D473X0035A2	150D473X9035A2	0.1	2
0.056	A	-	150D563X9035A2	0.1	2
0.068	A	150D683X0035A2	150D683X9035A2	0.1	2
0.082	A	-	150D823X9035A2	0.1	2
0.10	A	150D104X0035A2	150D104X9035A2	0.5	2
0.12	A	-	150D124X9035A2	0.5	2
0.15	A	150D154X0035A2	150D154X9035A2	0.5	2
0.18	A	-	150D184X9035A2	0.5	2
0.22	A	150D224X0035A2	150D224X9035A2	0.5	2
0.27	A	-	150D274X9035A2	0.5	2
0.33	A	150D334X0035A2	150D334X9035A2	0.5	2
0.39	A	-	150D394X9035A2	0.5	2
0.47	A	150D474X0035A2	150D474X9035A2	0.5	2
0.56	A	-	150D564X9035A2	0.5	2
0.68	A	150D684X0035A2	150D684X9035A2	0.5	2
0.82	A	-	150D824X9035A2	0.5	2
1.0	A	150D105X0035A2	150D105X9035A2	0.5	2
1.2	B	-	150D125X9035B2	0.5	4
1.5	B	150D155X0035B2	150D155X9035B2	0.5	4
1.8	B	-	150D185X9035B2	0.5	4
2.2	B	150D225X0035B2	150D225X9035B2	1.0	4
2.7	B	-	150D275X9035B2	1.0	4
3.3	B	150D335X0035B2	150D335X9035B2	1.0	4
3.9	B	-	150D395X9035B2	1.0	4
4.7	B	150D475X0035B2	150D475X9035B2	1.0	4
5.6	B	-	150D565X9035B2	1.0	4
6.8	B	150D685X0035B2	150D685X9035B2	2.0	4
8.2	R	-	150D825X9035R2	3.0	4
10.0	R	150D106X0035R2	150D106X9035R2	3.0	4
12.0	R	-	150D126X9035R2	3.0	4
15.0	R	150D156X0035R2	150D156X9035R2	3.0	4
18.0	R	-	150D186X9035R2	3.0	4
22.0	R	150D226X0035R2	150D226X9035R2	6.0	4
27.0	S	-	150D276X9035S2	6.0	4
33.0	S	150D336X0035S2	150D336X9035S2	6.0	4
39.0	S	-	150D396X9035S2	6.0	4
47.0	S	150D476X0035S2	150D476X9035S2	10.0	4

**Note**

(1) Insert capacitance tolerance code "X5" for ± 5 % units (special order)



Solid-Electrolyte TANTALEX® Capacitors  
Hermetically-Sealed, Axial-Lead

Vishay Sprague

STANDARD RATINGS						
CAPACITANCE (μF)	CASE CODE	PART NUMBER (1) CAP. TOL. ± 20 %	PART NUMBER (1) CAP. TOL. ± 10 %	Max. DCL AT + 25 °C	Max. DF AT + 25 °C	
<b>50 WVDC AT + 85 °C, SURGE = 65 V ... 33 WVDC AT + 125 °C, SURGE = 40 V</b>						
0.056	A	-	150D563X9050A2	0.1	2	
0.068	A	150D683X0050A2	150D683X9050A2	0.1	2	
0.082	A	-	150D823X9050A2	0.1	2	
0.10	A	150D104X0050A2	150D104X9050A2	0.5	2	
0.12	A	-	150D124X9050A2	0.5	2	
0.15	A	150D154X0050A2	150D154X9050A2	0.5	2	
0.18	A	-	150D184X9050A2	0.5	2	
0.22	A	150D224X0050A2	150D224X9050A2	0.5	2	
0.27	A	-	150D274X9050A2	0.5	2	
0.33	A	150D334X0050A2	150D334X9050A2	0.5	2	
0.39	A	-	150D394X9050A2	0.5	2	
0.47	A	150D474X0050A2	150D474X9050A2	0.5	2	
0.56	A	-	150D564X9050A2	0.5	2	
0.68	A	150D684X0050A2	150D684X9050A2	0.5	2	
0.82	A	-	150D824X9050A2	0.5	2	
1.0	A	150D105X0050A2	150D105X9050A2	0.5	2	
1.2	B	-	150D125X9050B2	0.5	4	
1.5	B	150D155X0050B2	150D155X9050B2	0.5	4	
1.8	B	-	150D185X9050B2	0.5	4	
2.2	B	150D225X0050B2	150D225X9050B2	1.0	4	
2.7	B	-	150D275X9050B2	1.0	4	
3.3	B	150D335X0050B2	150D335X9050B2	2.0	4	
3.9	B	-	150D395X9050B2	2.0	4	
4.7	B	150D475X0050B2	150D475X9050B2	3.0	4	
5.6	R	-	150D565X9050R2	3.0	4	
6.8	R	150D685X0050R2	150D685X9050R2	3.0	4	
8.2	R	-	150D825X9050R2	3.0	4	
10.0	R	150D106X0050R2	150D106X9050R2	3.0	4	
12.0	R	-	150D126X9050R2	3.0	4	
15.0	R	150D156X0050R2	150D156X9050R2	6.0	4	
18.0	R	-	150D186X9050R2	6.0	4	
22.0	S	150D226X0050S2	150D226X9050S2	6.0	4	
<b>60 WVDC AT + 85 °C, SURGE = 78 V ... 40 WVDC AT +125 °C, SURGE = 49 V</b>						
0.1	A	150D104X0060A2	150D104X9060A2	0.5	4.0	
0.12	A	150D124X0060A2	150D124X9060A2	0.5	4.0	
0.15	A	150D154X0060A2	150D154X9060A2	0.5	4.0	
0.18	A	150D184X0060A2	150D184X9060A2	0.5	4.0	
0.22	A	150D224X0060A2	150D224X9060A2	0.5	4.0	
0.27	A	150D274X0060A2	150D274X9060A2	0.5	4.0	
0.33	A	150D334X0060A2	150D334X9060A2	0.5	4.0	
0.39	A	150D394X0060A2	150D394X9060A2	0.5	4.0	
0.47	A	150D474X0060A2	150D474X9060A2	0.5	4.0	
0.56	A	150D564X0060A2	150D564X9060A2	0.5	4.0	
0.68	A	150D684X0060A2	150D684X9060A2	0.5	4.0	
1.0	B	150D105X0060B2	150D105X9060B2	0.5	4.0	
2.2	B	150D225X0060B2	150D225X9060B2	1.0	4.0	
4.7	R	150D475X0060R2	150D475X9060R2	3.0	6.0	
5.6	R	150D565X0060R2	150D565X9060R2	3.0	6.0	
6.8	R	150D685X0060R2	150D685X9060R2	4.0	6.0	
8.2	R	150D825X0060R2	150D825X9060R2	5.0	6.0	
10	R	150D106X0060R2	150D106X9060R2	6.0	6.0	
12	S	150D126X0060S2	150D126X9060S2	6.0	6.0	
15	S	150D156X0060S2	150D156X9060S2	9.0	6.0	
18	S	150D186X0060S2	150D186X9060S2	10.0	6.0	
22	S	150D226X0060S2	150D226X9060S2	12.0	6.0	

**Note**

(1) Insert capacitance tolerance code "X5" for ± 5 % units (special order)

<b>STANDARD RATINGS</b>					
CAPACITANCE (μF)	CASE CODE	PART NUMBER (1) CAP. TOL. ± 20 %	PART NUMBER (1) CAP. TOL. ± 10 %	Max. DCL AT + 25 °C (μA)	Max. DF AT + 25 °C 120 Hz (%)
<b>75 WVDC AT + 85 °C, SURGE = 98 V . . . 50 WVDC AT + 125 °C, SURGE = 64 V</b>					
0.033	A	150D333X0075A2	150D333X9075A2	0.5	2
0.039	A	-	150D393X9075A2	0.5	2
0.047	A	150D473X0075A2	150D473X9075A2	0.5	2
0.056	A	-	150D563X9075A2	0.5	2
0.068	A	150D683X0075A2	150D683X9075A2	0.5	2
0.082	A	-	150D823X9075A2	0.5	2
0.10	A	150D104X0075A2	150D104X9075A2	0.5	2
0.12	A	-	150D124X9075A2	0.5	2
0.15	A	150D154X0075A2	150D154X9075A2	0.5	2
0.18	A	-	150D184X9075A2	0.5	2
0.22	A	150D224X0075A2	150D224X9075A2	0.5	2
0.27	A	-	150D274X9075A2	0.5	2
0.33	A	150D334X0075A2	150D334X9075A2	0.5	2
0.39	A	-	150D394X9075A2	0.5	2
0.47	A	150D474X0075A2	150D474X9075A2	0.5	2
0.56	A	-	150D564X9075A2	0.5	2
0.68	A	150D684X0075A2	150D684X9075A2	0.5	2
0.82	B	-	150D824X9075B2	0.5	2
1.0	B	150D105X0075B2	150D105X9075B2	0.5	2
1.2	B	-	150D125X9075B2	0.5	4
1.5	B	150D155X0075B2	150D155X9075B2	1.0	4
1.8	B	-	150D185X9075B2	1.0	4
2.2	B	150D225X0075B2	150D225X9075B2	1.0	4
2.7	B	-	150D275X9075B2	1.0	4
3.3	B	150D335X0075B2	150D335X9075B2	2.0	4
3.9	B	-	150D395X9075B2	2.0	4
4.7	R	150D475X0075R2	150D475X9075R2	4.0	4
5.6	R	-	150D565X9075R2	4.0	4
6.8	R	150D685X0075R2	150D685X9075R2	6.0	4
8.2	R	-	150D825X9075R2	6.0	4
10.0	R	150D106X0075R2	150D106X9075R2	8.0	4
12.0	S	-	150D126X9075S2	10.0	4
15.0	S	150D156X0075S2	150D156X9075S2	12.0	4
<b>100 WVDC AT + 85 °C, SURGE = 130 V . . . 67 WVDC AT + 125 °C, SURGE = 86 V</b>					
0.033	A	150D333X0100A2	150D333X9100A2	0.5	2
0.039	A	-	150D393X9100A2	0.5	2
0.047	A	150D473X0100A2	150D473X9100A2	0.5	2
0.056	A	-	150D563X9100A2	0.5	2
0.068	A	150D683X0100A2	150D683X9100A2	0.5	2
0.082	A	-	150D823X9100A2	0.5	2
0.10	A	150D104X0100A2	150D104X9100A2	0.5	2
0.12	A	-	150D124X9100A2	0.5	2
0.15	A	150D154X0100A2	150D154X9100A2	0.5	2
0.18	A	-	150D184X9100A2	0.5	2
0.22	A	150D224X0100A2	150D224X9100A2	0.5	2
0.27	A	-	150D274X9100A2	0.5	2
0.33	A	150D334X0100A2	150D334X9100A2	0.5	2
0.39	A	-	150D394X9100A2	0.5	2
0.47	A	150D474X0100A2	150D474X9100A2	0.5	2
0.56	A	-	150D564X9100A2	0.5	2
0.68	B	150D684X0100B2	150D684X9100B2	0.5	2
0.82	B	-	150D824X9100B2	0.5	2

**Note**

(1) Insert capacitance tolerance code "X5" for ± 5 % units (special order)



Solid-Electrolyte TANTALEX® Capacitors  
Hermetically-Sealed, Axial-Lead

Vishay Sprague

<b>STANDARD RATINGS</b>					
CAPACITANCE (µF)	CASE CODE	PART NUMBER (1) CAP. TOL. ± 20 %	PART NUMBER (1) CAP. TOL. ± 10 %	Max. DCL AT + 25 °C (µA)	Max. DF AT + 25 °C 120 Hz (%)
<b>100 WVDC AT + 85 °C, SURGE = 130 V . . . 67 WVDC AT + 125 °C, SURGE = 86 V</b>					
1.0	B	150D105X0100B2	150D105X9100B2	0.5	2
1.2	B	-	150D125X9100B2	0.5	3
1.5	B	150D155X0100B2	150D155X9100B2	0.6	3
1.8	B	-	150D185X9100B2	0.6	3
2.2	B	150D225X0100B2	150D225X9100B2	0.6	3
2.7	B	-	150D275X9100B2	0.6	3
3.3	R	150D335X0100R2	150D335X9100R2	2.5	3
3.9	R	-	150D395X9100R2	3.0	3
4.7	R	150D475X0100R2	150D475X9100R2	4.0	3
5.6	R	-	150D565X9100R2	4.0	3
6.8	R	150D685X0100R2	150D685X9100R2	6.0	3
8.2	S	150D825X0100S2	150D825X9100S2	6.0	3
10	S	150D106X0100S2	150D106X9100S2	6.0	3
<b>125 WVDC AT + 85 °C, SURGE = 140 V . . . 82 WVDC AT + 125 °C, SURGE = 94 V</b>					
0.027	A	-	150D273X9125A2	1.0	2
0.033	A	150D333X0125A2	150D333X9125A2	1.0	2
0.039	A	-	150D393X9125A2	1.0	2
0.047	A	150D473X0125A2	150D473X9125A2	1.0	2
0.056	A	-	150D563X9125A2	1.0	2
0.068	A	150D683X0125A2	150D683X9125A2	1.0	2
0.082	A	-	150D823X9125A2	1.0	2
0.10	A	150D104X0125A2	150D104X9125A2	1.0	2
0.12	A	-	150D124X9125A2	1.0	2
0.15	A	150D154X0125A2	150D154X9125A2	1.0	2
0.18	A	-	150D184X9125A2	1.0	2
0.22	A	150D224X0125A2	150D224X9125A2	1.0	2
0.27	A	-	150D274X9125A2	1.0	2
0.33	A	150D334X0125A2	150D334X9125A2	1.0	2
0.39	A	-	150D394X9125A2	1.5	2
0.47	A	150D474X0125A2	150D474X9125A2	1.5	2
0.56	B	-	150D564X9125B2	1.6	2
0.68	B	150D684X0125B2	150D684X9125B2	1.8	2
0.82	B	-	150D824X9125B2	2.0	2
1.0	B	150D105X0125B2	150D105X9125B2	2.0	2
1.2	B	-	150D125X9125B2	2.0	3
1.5	B	150D155X0125B2	150D155X9125B2	2.0	3
1.8	B	-	150D185X9125B2	2.0	3
2.2	B	150D225X0125B2	150D225X9125B2	2.0	3

**Note**

(1) Insert capacitance tolerance code "X5" for ± 5 % units (special order).



**STANDARD REEL PACKAGING SPECIFICATIONS - MEETS EIA STANDARD RS-296 in inches [millimeters]**

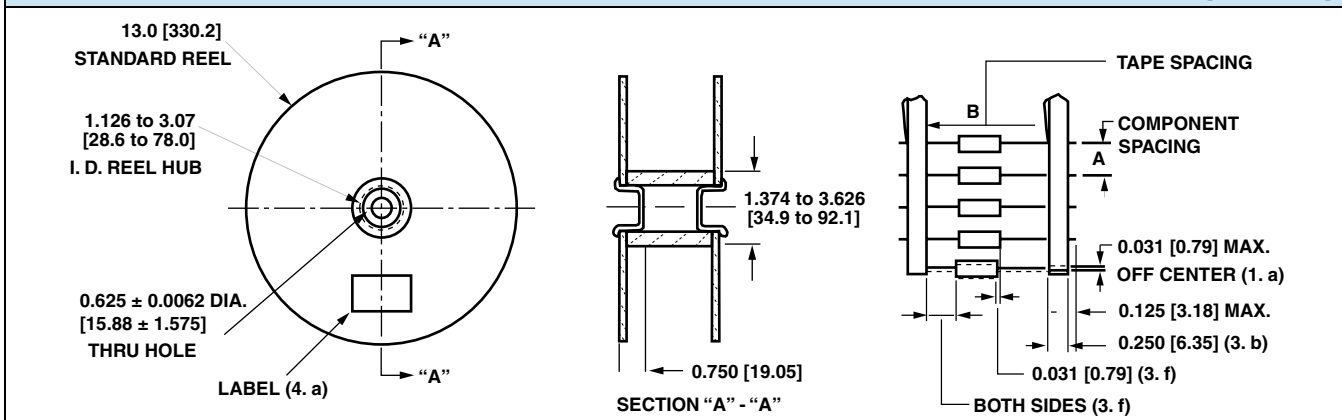

CASE CODE	TYPE 150D UNITS WITH INSULATING SLEEVE		LEAD SIZE		COMPONENT SPACING	TAPE SPACING	UNITS PER REEL
	D	L	AWG NO.	NOM. DIA.	A	B	
A	0.135 ± 0.016 [3.43 ± 0.41]	0.286 ± 0.031 [7.26 ± 0.79]	24	0.020 [0.51]	0.200 ± 0.015 [5.08 ± 0.38]	2.500 ± 0.062 [63.5 ± 1.57]	1000
B	0.185 ± 0.016 [4.70 ± 0.41]	0.474 ± 0.031 [12.04 ± 0.79]	24	0.020 [0.51]	0.200 ± 0.015 [5.08 ± 0.38]	2.500 ± 0.062 [63.5 ± 1.57]	1000
R	0.289 ± 0.016 [7.34 ± 0.41]	0.686 ± 0.031 [17.42 ± 0.79]	22	0.025 [0.64]	0.400 ± 0.015 [10.16 ± 0.38]	2.875 ± 0.062 [73.03 ± 1.57]	500
S	0.351 ± 0.016 [8.92 ± 0.41]	0.786 ± 0.031 [19.96 ± 0.79]	22	0.025 [0.64]	0.400 ± 0.015 [10.16 ± 0.38]	2.875 ± 0.062 [73.03 ± 1.57]	500

**STANDARD REEL PACKAGING INFORMATION**

**1. Component Leads:**

- a. Component leads shall not be bent beyond 0.047" [1.19 mm] maximum from their nominal position when measured from the leading edge of the component lead at the inside tape edge and at the lead egress from the component.
- b. The "C" dimension shall be governed by the overall length of the reel packaged component. The distance between flanges shall be 0.125" to 0.250" [3.18 mm to 6.35 mm] greater than the overall component length.

**2. Orientation:**

All polarized components must be oriented to one direction. The cathode lead tape shall be a color and the anode lead tape shall be white.

**3. Reeling:**

- a. Components on any reel shall not represent more than two date codes when date code identification is required.
- b. Component leads shall be positioned between pairs of 0.250" [6.35 mm] tape.
- c. The disposable reels have hubs and corrugated fibreboard flanges and core or equivalent.
- d. A minimum of 12.0" [304.8 mm] leader of tape shall be provided before the first and after the last component on the reel.
- e. 50 or 60 lb. Kraft paper must be wound between layer of components as far as necessary for component protection. Width of paper to be 0.062" to 0.250" [1.57 mm to 6.35 mm] less than the "C" dimension of the reel. Solid-Electrolyte TANTALEX® Capacitors Hermetically- Sealed, Axial-Lead.

- f. A row of components must be centered between tapes ± 0.047" [1.19 mm]. In addition, individual components may deviate from center of component row ± 0.031" [0.79 mm].
- g. Staples shall not be used for splicing. Not more than 4 layers of tape shall be used in any splice area and no tape shall be offset from another by more than 0.031" [0.79 mm] non-cumulative. Tape splices shall overlap at least 6.0" [152.4 mm] for butt joints and at least 3.0" [76.2 mm] for lap joints and shall not be weaker than unspliced tape. Universal splicing clips may also be used.
- h. Quantity per reel shall be controlled so that tape components and cover shall not extend beyond the smallest dimension of the flange (either across flats or diameter). Once the quantity per reel for each part number has been established, future orders for that part number shall be packaged in that quantity. When order or release quantity is less than the established quantity, a standard commercial pack is to be used.
- i. A maximum of 0.25 % of the components per reel quantity may be missing without consecutive missing components.
- j. Adequate protection must be provided to prevent physical damage to both reel and components during shipment and storage.

**4. Marking:**

Minimum reel and carton marking shall consist of the following: Customer Part Number, Purchase Order No., Quantity, Package Date, Manufacturer's Name, Electrical Value, Date Code, Vishay Sprague Part Number and Country of Origin.



## Disclaimer

All product specifications and data are subject to change without notice.

Vishay Intertechnology, Inc., its affiliates, agents, and employees, and all persons acting on its or their behalf (collectively, "Vishay"), disclaim any and all liability for any errors, inaccuracies or incompleteness contained herein or in any other disclosure relating to any product.

Vishay disclaims any and all liability arising out of the use or application of any product described herein or of any information provided herein to the maximum extent permitted by law. The product specifications do not expand or otherwise modify Vishay's terms and conditions of purchase, including but not limited to the warranty expressed therein, which apply to these products.

No license, express or implied, by estoppel or otherwise, to any intellectual property rights is granted by this document or by any conduct of Vishay.

The products shown herein are not designed for use in medical, life-saving, or life-sustaining applications unless otherwise expressly indicated. Customers using or selling Vishay products not expressly indicated for use in such applications do so entirely at their own risk and agree to fully indemnify Vishay for any damages arising or resulting from such use or sale. Please contact authorized Vishay personnel to obtain written terms and conditions regarding products designed for such applications.

Product names and markings noted herein may be trademarks of their respective owners.