

Key Features

- SMPTE 259M-C compliant descrambling and NRZI to NRZ decoding (with bypass)
- DVB-ASI sync word detection and 8b/10b decoding
- Integrated Cable Equalizer
- 500m typical equalization of Belden 1694A cable
- Integrated line-based FIFO for data alignment/delay, clock phase interchange, DVB-ASI data packet extraction and clock rate interchange, and ancillary data packet extraction
- Integrated VCO and reclocker
- Automatic or manual selection between SMPTE video and DVB-ASI data
- User selectable additional processing features including:
 - TRS, ANC data checksum, and EDH CRC error detection and correction
 - programmable ANC data detection
 - illegal code remapping
- Internal flywheel for noise immune H, V, F extraction
- Automatic standards detection and indication
- Enhanced Gennum Serial Peripheral Interface (GSPI)
- JTAG test interface
- Polarity insensitive for DVB-ASI and SMPTE signals
- +1.8V core power supply with optional +1.8V or +3.3V I/O power supply
- Small footprint (11mm x 11mm)
- Low power operation (typically 350mW)
- Pb-free and RoHS compliant

Applications

- SMPTE 259M-C Serial Digital Interfaces
- DVB-ASI Serial Digital Interfaces

Description

The GS9091B is a 270Mb/s equalizing and reclocking deserializer with an internal FIFO. It provides a complete receive solution for SD-SDI and DVB-ASI applications.

In addition to equalizing, reclocking and deserializing the input data stream, the GS9091B performs NRZI-to-NRZ decoding, descrambling as per SMPTE 259M-C, and word alignment when operating in SMPTE mode. When operating in DVB-ASI mode, the device will word align the data to K28.5 sync characters and 8b/10b decode the received stream.

The integrated equalizer is optimized for 270Mb/s and can typically equalize up to 500m of Belden 1694A cable. Both the equalizer and the internal reclocker are fully compatible with both SMPTE and DVB-ASI input streams.

The GS9091B includes a range of data processing functions such as EDH support (error detection and handling), and automatic standards detection. The device can also detect and extract SMPTE 352M payload identifier packets and independently identify the received video standard. This information is read from internal registers via the host interface port.

The GS9091B also incorporates a video line-based FIFO. This FIFO may be used in four user-selectable modes to carry out tasks such as data alignment / delay, clock phase interchange, MPEG packet extraction and clock rate interchange, and ancillary data packet extraction.

Parallel data outputs are provided in 10-bit multiplexed format, with the associated parallel clock output signal operating at 27MHz.

The device may also be used in a low-latency data pass through mode where only descrambling and word alignment will be performed in SMPTE mode.

Functional Block Diagram

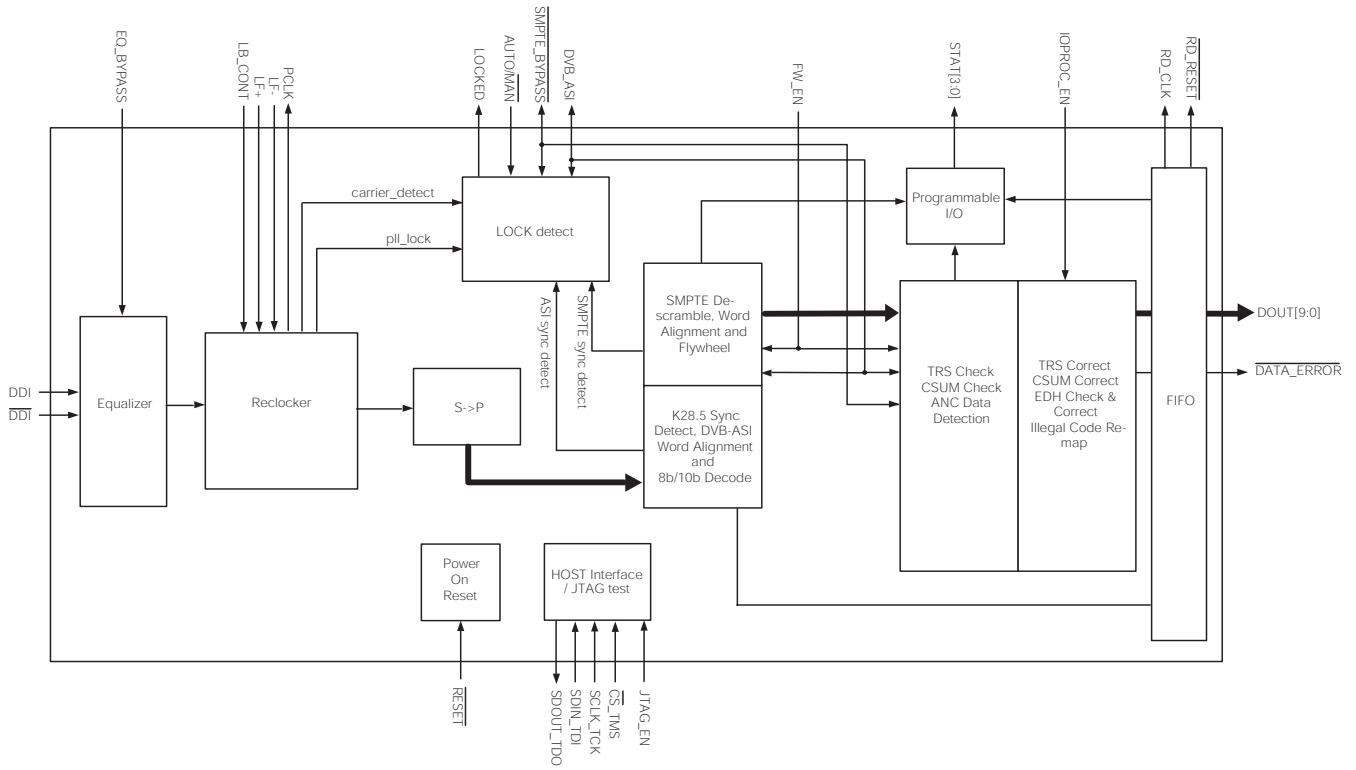

GS9091B Functional Block Diagram

Contents

Key Features	1
Applications	1
Description	1
Functional Block Diagram	2
1. Pin Out	5
1.1 Pin Assignment	5
2. Electrical Characteristics	12
2.1 DC Electrical Characteristics	12
2.2 AC Electrical Characteristics	13
2.3 Solder Reflow Profiles	15
2.4 Host Interface Map	16
2.4.1 Host Interface Map (R/W registers)	18
2.4.2 Host Interface Map (Read only registers)	20
3. Detailed Description	22
3.1 Functional Overview	22
3.2 Cable Equalization	23
3.3 Clock and Data Recovery	23
3.3.1 Internal VCO and Phase Detector	23
3.4 Serial-To-Parallel Conversion	23
3.5 Modes Of Operation	23
3.5.1 Lock Detect	24
3.5.2 Auto Mode	26
3.5.3 Manual Mode	26
3.6 SMPTE Functionality	27
3.6.1 SMPTE Descrambling and Word Alignment	27
3.6.2 Internal Flywheel	27
3.6.3 Switch Line Lock Handling	28
3.6.4 HVF Timing Signal Generation	29
3.7 DVB-ASI Functionality	30
3.7.1 DVB-ASI 8b/10b Decoding	31
3.7.2 Status Signal Outputs	31
3.8 Data-Through Functionality	31
3.9 Additional Processing Features	32
3.9.1 FIFO Load Pulse	32
3.9.2 Ancillary Data Detection and Indication	33
3.9.3 EDH Packet Detection	34
3.9.4 EDH Flag Detection	35
3.9.5 SMPTE 352M Payload Identifier	38
3.9.6 Automatic Video Standard and Data Format Detection	39
3.9.7 Error Detection and Indication	40

3.9.8 Additional SMPTE Mode Processing	45
3.10 Internal FIFO Operation	48
3.10.1 Video Mode.....	48
3.10.2 DVB-ASI Mode	50
3.10.3 Ancillary Data Extraction Mode.....	53
3.10.4 Bypass Mode	55
3.11 Parallel Data Outputs.....	56
3.11.1 Parallel Data Bus Output Buffers.....	56
3.11.2 Parallel Output in SMPTE Mode.....	57
3.11.3 Parallel Output in DVB-ASI Mode.....	57
3.11.4 Parallel Output in Data-Through Mode	57
3.12 Programmable Multi-Function Outputs	57
3.13 GS9091B Low-latency Mode	59
3.14 GSPI Host Interface	60
3.14.1 Command Word Description.....	60
3.14.2 Data Read and Write Timing	61
3.14.3 Configuration and Status Registers	63
3.15 JTAG operation	64
3.16 Device Power Up	65
4. References & Relevant Standards	66
5. Application Information.....	67
5.1 Typical Application Circuit.....	67
6. Package & Ordering Information.....	68
6.1 Package Dimensions	68
6.2 Packaging Data.....	69
6.3 Marking Diagram.....	69
6.4 Ordering Information	69
7. Revision History	70

1. Pin Out

1.1 Pin Assignment

	1	2	3	4	5	6	7	8	9	10
A	LF+	NC	LB_CONT	VCO_VDD	VBG	FIFO_EN	AUTO/MAN	LOCKED	PCLK	DOUT9
B	LF-	PLL_VDD	PLL_GND	VCO_GND	NC	FW_EN	CORE_VDD	SMPTE_BYPASS	DVB_ASI	DOUT8
C	ANA_VDD	ANA_VDD	NC	NC	NC	NC	NC	IO_VDD	NC	DOUT7
D	ANA_GND	ANA_GND	NC	CORE_GND	CORE_GND	IO_GND	IO_GND	NC	NC	DOUT6
E	EQ_GND	TERM	NC	CORE_GND	CORE_GND	IO_GND	IO_GND	NC	IO_VDD	DOUT5
F	SDI	HEAT_SINK_GND	HEAT_SINK_GND	CORE_GND	CORE_GND	IO_GND	IO_GND	NC	IO_VDD	DOUT4
G	$\overline{\text{SDI}}$	HEAT_SINK_GND	HEAT_SINK_GND	CORE_GND	CORE_GND	IO_GND	IO_GND	NC	NC	DOUT3
H	EQ_VDD	HEAT_SINK_GND	HEAT_SINK_GND	NC	NC	NC	NC	IO_VDD	$\overline{\text{RD_RESET}}$	DOUT2
J	AGC+	EQ_BYPASS	JTAG_EN	$\overline{\text{CS_TMS}}$	SDOUT_TDO	CORE_VDD	$\overline{\text{DATA_ERROR}}$	STAT2	STAT3	DOUT1
K	AGC-	NC	IOPROC_EN	$\overline{\text{RESET}}$	SCLK_TCK	SDIN_TDI	STAT0	STAT1	RD_CLK	DOUT0

Figure 1-1: Pin Assignment

Table 1-1: Ball List and Description

Ball	Name	Timing	Type	Description
A1	LF+	Analog	Input	Loop filter component connection. Connect to LF- through a 4.4nF capacitor.
A2, B5, C3, C4, C5, C6, C7, C9, D3, D8, D9, E3, E8, F8, G8, G9, H4, H5, H6, H7, K2	NC	–	–	No connect. Not connected internally.
A3	LB_CONT	Analog	Input	CONTROL SIGNAL INPUT Control voltage to fine-tune the loop bandwidth of the PLL.
A4	VCO_VDD	Analog	Input Power	Power supply connection for Voltage-Controlled-Oscillator. Connect to +1.8V DC.
A5	VBG	Analog	Input	Bandgap filter capacitor. Connect to GND as shown in Typical Application Circuit .
A6	FIFO_EN	Non Synchronous	Input	CONTROL SIGNAL INPUT Signal levels are LVCMOS / LVTTTL compatible. Used to enable / disable the internal FIFO. When FIFO_EN is HIGH, the internal FIFO will be enabled. Data will be clocked out of the device on the rising edge of the RD_CLK input pin if the FIFO is in video mode or DVB-ASI mode. When FIFO_EN is LOW, the internal FIFO is bypassed and parallel data is clocked out on the rising edge of the PCLK output.
A7	AUTO/ $\overline{\text{MAN}}$	Non Synchronous	Input	CONTROL SIGNAL INPUT Signal levels are LVCMOS / LVTTTL compatible. When set HIGH, the GS9091B will operate in Auto mode. The DVB_ASI and SMPTE_BYPASS pins become output status signals set by the device. In this mode, the GS9091B will automatically detect, reclock, deserialize, and process SMPTE or DVB-ASI compliant input data. When set LOW, the GS9091B will operate in Manual mode. The DVB_ASI and SMPTE_BYPASS pins become input control signals. In this mode, the application layer must set these two external pins for the correct reception of either SMPTE or DVB-ASI data. Manual mode also supports the reclocking and deserializing of data not conforming to SMPTE or DVB-ASI streams.
A8	LOCKED	Synchronous with PCLK	Output	STATUS SIGNAL OUTPUT Signal levels are LVCMOS / LVTTTL compatible. The LOCKED pin will be HIGH whenever the device has correctly received and locked to SMPTE compliant data in SMPTE mode or DVB-ASI compliant data in DVB-ASI mode, or when the reclocker has achieved lock in Data-Through mode. It will be LOW otherwise. When the pin is LOW, all digital output signals will be forced to logic LOW levels.
A9	PCLK	–	Output	PIXEL CLOCK OUTPUT Signal levels are LVCMOS / LVTTTL compatible. 27MHz parallel clock output.

Table 1-1: Ball List and Description (Continued)

Ball	Name	Timing	Type	Description
A10, B10, C10, D10, E10, F10, G10, H10, J10, K10	DOUT[9:0]	Synchronous with RD_CLK or PCLK	Output	<p>PARALLEL VIDEO DATA BUS Signal levels are LVCMOS / LVTTTL compatible.</p> <p>When the internal FIFO is enabled and configured for either video mode or DVB-ASI mode, parallel data will be clocked out of the device on the rising edge of RD_CLK.</p> <p>When the internal FIFO is in bypass mode, parallel data will be clocked out of the device on the rising edge of PCLK.</p> <p>DOUT9 is the MSB and DOUT0 is the LSB.</p>
B1	LF-	Analog	Input	Loop filter component connection. Connect to LF+ through a 4.4nF capacitor.
B2	PLL_VDD	Analog	Input Power	Power supply connection for phase-locked loop. Connect to +1.8V DC.
B3	PLL_GND	Analog	Input Power	Ground connection for phase-locked loop. Connect to GND.
B4	VCO_GND	Analog	Input Power	Ground connection for Voltage-Controlled-Oscillator. Connect to GND.
B6	FW_EN	Non Synchronous	Input	<p>CONTROL SIGNAL INPUT Signal levels are LVCMOS / LVTTTL compatible.</p> <p>Used to enable or disable the noise immune flywheel of the device.</p> <p>When set HIGH, the internal flywheel is enabled. This flywheel is used in the extraction of timing signals, the generation of TRS signals, the automatic detection of video standards, and in manual switch line lock handling.</p> <p>When set LOW, the internal flywheel is disabled. Timing based TRS errors will not be detected.</p>
B7, J6	CORE_VDD	Non Synchronous	Input Power	Power supply for digital logic blocks. Connect to +1.8V DC.
B8	$\overline{\text{SMPTE_BYPASS}}$	Non Synchronous	Input / Output	<p>CONTROL SIGNAL INPUT / STATUS SIGNAL OUTPUT Signal levels are LVCMOS / LVTTTL compatible.</p> <p>This pin is an input set by the application layer in Manual mode, and an output set by the device in Auto mode.</p> <p>Auto Mode ($\overline{\text{AUTO/MAN}} = \text{HIGH}$): The SMPTE_BYPASS pin will be HIGH only when the device has locked to a SMPTE compliant data stream. It will be LOW otherwise. When the pin is LOW, no I/O processing features are available.</p> <p>Manual Mode ($\overline{\text{AUTO/MAN}} = \text{LOW}$): When the application layer sets this pin HIGH in conjunction with DVB_ASI = LOW, the device will be configured to operate in SMPTE mode. All I/O processing features may be enabled in this mode.</p> <p>When $\overline{\text{SMPTE_BYPASS}}$ is set LOW, the device will not support the descrambling, decoding, or word alignment of received SMPTE data. No I/O processing features will be available.</p>

Table 1-1: Ball List and Description (Continued)

Ball	Name	Timing	Type	Description
B9	DVB_ASI	Non Synchronous	Input / Output	<p>CONTROL SIGNAL INPUT / STATUS SIGNAL OUTPUT Signal levels are LVCMOS / LVTTTL compatible.</p> <p>This pin is an input set by the application layer in Manual mode, and an output set by the device in Auto mode.</p> <p>Auto Mode (AUTO/MAN = HIGH): The DVB_ASI pin will be HIGH only when the device has locked to a DVB-ASI compliant data stream. It will be LOW otherwise.</p> <p>Manual Mode (AUTO/MAN = LOW): When the application layer sets this pin HIGH, the device will be configured to operate in DVB-ASI mode. The SMPTE_BYPASS pin will be ignored.</p> <p>When set LOW, the device will not support the decoding or word alignment of received DVB-ASI data.</p>
C1, C2	ANA_VDD	Analog	Input Power	Power supply connection for analog core. Connect to +3.3V DC.
C8, E9, F9, H8	IO_VDD	Non Synchronous	Input Power	<p>Power supply for digital I/O.</p> <p>For a 3.3V tolerant I/O, connect pins to either +1.8V DC or +3.3V DC.</p> <p>For a 5V tolerant I/O, connect pins to a +3.3V DC.</p>
D1, D2	ANA_GND	Analog	Input Power	Ground connection for analog core. Connect to GND.
D4, D5, E4, E5, F4, F5, G4, G5	CORE_GND	Non Synchronous	Input Power	Ground connection for digital logic blocks. Connect to GND.
D6, D7, E6, E7, F6, F7, G6, G7	IO_GND	Non Synchronous	Input Power	Ground connection for digital I/O. Connect to GND.
E1	EQ_GND	Analog	Input Power	Ground connection for equalizer core. Connect to GND.
E2	TERM	Analog	Input	Termination for serial digital input. AC couple to ANA_GND
F1, G1	SDI, $\overline{\text{SDI}}$	Analog	Input	Serial digital differential input pair.
F2, F3, G2, G3, H2, H3	HEAT_SINK_GND	Analog	Input Power	Heat sink connection. Connect to main ground plane of application board.
H1	EQ_VDD	Analog	Input Power	Power supply connection for equalizer core. Connect to +3.3V DC.
H9	$\overline{\text{RD_RESET}}$	Synchronous with RD_CLK	Input	<p>FIFO READ RESET Signal levels are LVCMOS / LVTTTL compatible.</p> <p>Valid input only when the device is in SMPTE mode (SMPTE_BYPASS = HIGH and DVB-ASI = LOW), and the internal FIFO is configured for video mode (Section 3.10.1).</p> <p>A HIGH to LOW transition will reset the FIFO pointer to address zero of the memory.</p>
J1, K1	AGC+, AGC-	Analog	Input	External AGC capacitor connection. Connect J1 and K1 together through a 1uF capacitor.

Table 1-1: Ball List and Description (Continued)

Ball	Name	Timing	Type	Description
J2	EQ_BYPASS	Analog	Input	<p>CONTROL SIGNAL INPUT Signal levels are 3.3V CMOS / LVTTTL compatible.</p> <p>Equalizer bypass.</p> <p>When EQ_BYPASS is HIGH, the equalizer stages are bypassed.</p> <p>When EQ_BYPASS is LOW, normal operation of the equalizer stages resumes.</p>
J3	JTAG_EN	Non Synchronous	Input	<p>CONTROL SIGNAL INPUT Signal levels are LVCMOS / LVTTTL compatible.</p> <p>Used to select JTAG Test Mode or Host Interface Mode.</p> <p>When set HIGH, $\overline{\text{CS_TMS}}$, SCLK_TCK, SDOUT_TDO, and SDIN_TDI are configured for JTAG boundary scan testing.</p> <p>When set LOW, $\overline{\text{CS_TMS}}$, SCLK_TCK, SDOUT_TDO, and SDIN_TDI are configured as GSPI pins for normal host interface operation.</p>
J4	$\overline{\text{CS_TMS}}$	Synchronous with SCLK_TCK	Input	<p>CONTROL SIGNAL INPUT Signal levels are LVCMOS / LVTTTL compatible.</p> <p>Chip Select / Test Mode Select</p> <p>Host Mode (JTAG_EN = LOW): $\overline{\text{CS_TMS}}$ operates as the host interface chip select, $\overline{\text{CS}}$, and is active LOW.</p> <p>JTAG Test Mode (JTAG_EN = HIGH): $\overline{\text{CS_TMS}}$ operates as the JTAG test mode select, TMS, and is active HIGH.</p>
J5	SDOUT_TDO	Synchronous with SCLK_TCK	Output	<p>CONTROL SIGNAL INPUT Signal levels are LVCMOS / LVTTTL compatible.</p> <p>Serial Data Output / Test Data Output</p> <p>Host Mode (JTAG_EN = LOW): SDOUT_TDO operates as the host interface serial output, SDOUT, used to read status and configuration information from the internal registers of the device.</p> <p>JTAG Test Mode (JTAG_EN = HIGH): SDOUT_TDO operates as the JTAG test data output, TDO.</p>
J7	$\overline{\text{DATA_ERROR}}$	Synchronous with PCLK	Output	<p>STATUS SIGNAL OUTPUT. Signal levels are LVCMOS / LVTTTL compatible.</p> <p>The $\overline{\text{DATA_ERROR}}$ pin will be LOW when an error within the received data stream has been detected by the device. This pin is an inverted logical 'OR'ing of all detectable errors listed in the internal ERROR_STATUS register.</p> <p>Once an error is detected, $\overline{\text{DATA_ERROR}}$ will remain LOW until the start of the next video frame / field, or until the ERROR_STATUS register is read via the host interface.</p> <p>The $\overline{\text{DATA_ERROR}}$ pin will be HIGH when the received data stream has been detected without error.</p> <p>NOTE: It is possible to program which error conditions are monitored by the device by setting appropriate bits in the ERROR_MASK register HIGH. All error conditions are detected by default.</p>

Table 1-1: Ball List and Description (Continued)

Ball	Name	Timing	Type	Description
K3	IOPROC_EN	Non Synchronous	Input	<p>CONTROL SIGNAL INPUT Signal Levels are LVCMOS / LVTTTL compatible.</p> <p>Used to enable or disable the I/O processing features.</p> <p>When set HIGH, the following I/O processing features of the device are enabled:</p> <ul style="list-style-type: none"> • Illegal Code Remapping • EDH CRC Error Correction • Ancillary Data Checksum Error Correction • TRS Error Correction • EDH Flag Detection <p>To enable a subset of these features, keep IOPROC_EN HIGH and disable the individual feature(s) in the IOPROC_DISABLE register accessible via the host interface.</p> <p>When set LOW, the device will enter low-latency mode.</p> <p>NOTE: When the internal FIFO is configured for Video mode or Ancillary Data Extraction mode, IOPROC_EN must be set HIGH (see Section 3.10).</p>
K4	$\overline{\text{RESET}}$	Non Synchronous	Input	<p>CONTROL SIGNAL INPUT Signal levels are LVCMOS / LVTTTL compatible.</p> <p>Used to reset the internal operating conditions to default setting or to reset the JTAG test sequence.</p> <p>Host Mode (JTAG_EN = LOW): When asserted LOW, all functional blocks will be set to default conditions and all input and output signals become high impedance.</p> <p>When set HIGH, normal operation of the device resumes 10usec after the LOW-to-HIGH transition of the $\overline{\text{RESET}}$ signal.</p> <p>JTAG Test Mode (JTAG_EN = HIGH): When asserted LOW, all functional blocks will be set to default and the JTAG test sequence will be held in reset.</p> <p>When set HIGH, normal operation of the JTAG test sequence resumes.</p>
K5	SCLK_TCK	Non Synchronous	Input	<p>CONTROL SIGNAL INPUT Signal levels are LVCMOS / LVTTTL compatible.</p> <p>Serial Data Clock / Test Clock. All JTAG / Host Interface address and data are shifted into/out of the device synchronously with this clock.</p> <p>Host Mode (JTAG_EN = LOW): SCLK_TCK operates as the host interface serial data clock, SCLK.</p> <p>JTAG Test Mode (JTAG_EN = HIGH): SCLK_TCK operates as the JTAG test clock, TCK.</p>
K6	SDIN_TDI	Synchronous with SCLK_TCK	Input	<p>CONTROL SIGNAL INPUT Signal levels are LVCMOS / LVTTTL compatible.</p> <p>Serial Data Input / Test Data Input</p> <p>Host Mode (JTAG_EN = LOW): SDIN_TDI operates as the host interface serial input, SDIN, used to write address and configuration information to the internal registers of the device.</p> <p>JTAG Test Mode (JTAG_EN = HIGH): SDIN_TDI operates as the JTAG test data input, TDI.</p>

Table 1-1: Ball List and Description (Continued)

Ball	Name	Timing	Type	Description
K7, K8, J8, J9	STAT[0:3]	Synchronous with PCLK or RD_CLK	Output	<p>MULTI FUNCTION I/O PORT Signal levels are LVCMOS / LVTTTL compatible.</p> <p>Programmable multi-function outputs. By programming the bits in the IO_CONFIG register, each pin can output one of the following signals:</p> <ul style="list-style-type: none"> • H • V • F • $\overline{\text{FIFO_LD}}$ • ANC • EDH_DETECT • FIFO_FULL • FIFO_EMPTY <p>These pins are set to certain default values depending on the configuration of the device and the internal FIFO mode selected. See Section 3.12 for details.</p>
K9	RD_CLK	–	Input	<p>FIFO READ CLOCK Signal levels are LVCMOS / LVTTTL compatible.</p> <p>The application layer clocks the parallel data out of the FIFO on the rising edge of RD_CLK.</p>

2. Electrical Characteristics

Table 2-1: Absolute Maximum Ratings

Parameter	Value/Units
Supply Voltage Core	-0.3V to +2.1V
Supply Voltage I/O	-0.3V to +3.47V
Input Voltage Range (LF+, LF-, LB_CONT, VBG)	-0.5V to +2.3V
Input Voltage Range (SDI, $\overline{\text{SDI}}$, AGC+, AGC-, EQ_BYPASS)	-0.5V to +3.6V
Input Voltage Range (All Other)	-0.5V to +5.25V
Ambient Operating Temperature	$-20^{\circ}\text{C} \leq T_A \leq 85^{\circ}\text{C}$
Storage Temperature	$-40^{\circ}\text{C} \leq T_{\text{STG}} \leq 125^{\circ}\text{C}$
ESD protection on all pins (see Note 1)	1kV

NOTES:

1. MIL STD 883 ESD protection will be applied to all pins on the device.

Absolute Maximum Ratings are those values beyond which damage to the device may occur. Functional operation under these conditions or at any other condition beyond those indicated in the AC/DC Electrical Characteristic sections is not implied.

2.1 DC Electrical Characteristics

Table 2-2: DC Electrical Characteristics

$V_{\text{DD}} = 1.8\text{V} \pm 5\%$, $3.3\text{V} \pm 5\%$; $T_A = 0^{\circ}\text{C}$ to 70°C , unless otherwise specified. Typical values: $V_{\text{CC}} = 1.8\text{V}$, 3.3V and $T_A = 25^{\circ}\text{C}$

Parameter	Symbol	Condition	Min	Typ	Max	Units	Notes
System							
Operating Temperature Range	T_A	–	0	25	70	$^{\circ}\text{C}$	1
Core Power Supply Voltage	CORE_VDD	–	1.71	1.8	1.89	V	–
Analog Core Power Supply Voltage	ANA_VDD	–	3.13	3.3	3.47	V	–
Digital I/O Buffer Power Supply Voltage	IO_VDD	1.8V Operation	1.71	1.8	1.89	V	–
		3.3V Operation	3.13	3.3	3.47	V	–
PLL Power Supply Voltage	PLL_VDD	–	1.71	1.8	1.89	V	–
VCO Power Supply Voltage	VCO_VDD	–	1.71	1.8	1.89	V	–
Equalizer Power Supply Voltage	EQ_VDD	–	3.13	3.3	3.47	V	–
Core Supply Current	I_{DD}	Total 1.8V Supply	–	64	80	mA	2
		Total 3.3V Supply	–	69	92	mA	3

Table 2-2: DC Electrical Characteristics (Continued)

$V_{DD} = 1.8V \pm 5\%$, $3.3V \pm 5\%$; $T_A = 0^\circ C$ to $70^\circ C$, unless otherwise specified. Typical values: $V_{CC} = 1.8V$, $3.3V$ and $T_A = 25^\circ C$

Parameter	Symbol	Condition	Min	Typ	Max	Units	Notes
I/O Supply Current	I_{IO}	I/O Supply, 1.8V Operation	–	4.5	8	mA	4
		I/O Supply, 3.3V Operation	–	8.5	14	mA	4
Power Dissipation	P_D	CORE_VDD = 1.8V IO_VDD = 1.8V	–	350	–	mW	–
		CORE_VDD = 1.89V IO_VDD = 3.47V	–	–	490	mW	–
Digital I/O							
Input Voltage, Logic LOW	V_{IL}	1.8V Operation or 3.3V Operation	–	–	0.35 x IO_VDD	V	–
Input Voltage, Logic HIGH	V_{IH}	1.8V Operation or 3.3V Operation	0.65 x IO_VDD	–	–	V	–
Output Voltage, Logic LOW	V_{OL}	$I_{OL} = 8mA @ 3.3V$, $4mA @ 1.8V$	–	–	0.4	V	–
Output Voltage, Logic HIGH	V_{OH}	$I_{OL} = -8mA @ 3.3V$, $-4mA @ 1.8V$	IO_VDD - 0.4	–	–	V	–
EQ_BYPASS Input Voltage	V_{IL}	Logic LOW	–	–	0.8	V	–
	V_{IH}	Logic HIGH	2.4	–	–	V	–
Serial Digital Inputs							
Input Common Mode Voltage	V_{CMIN}	$T_A = 25^\circ C$	–	1.75	–	V	–
Input Resistance	–	single ended	–	1.64	–	k Ω	–

NOTES

1. All DC and AC electrical parameters within specification.
2. Maximum supply current at $T_A = 0^\circ C$ and $V_{DD} = 1.89V$ supply.
3. Maximum supply current at $T_A = 75^\circ C$ and $V_{DD} = 3.47V$ supply.
4. I/O currents are based on output drivers driving one CMOS load.

2.2 AC Electrical Characteristics

Table 2-3: AC Electrical Characteristics

$V_{DD} = 1.8V \pm 5\%$, $3.3V \pm 5\%$; $T_A = 0^\circ C$ to $70^\circ C$, unless otherwise specified. Typical values: $V_{CC} = 1.8V$, $3.3V$ and $T_A = 25^\circ C$

Parameter	Symbol	Condition	Min	Typ	Max	Units	Notes
System							
Input Voltage Swing	ΔV_{SDI}	$T_A = 25^\circ C$, differential	720	800	950	mV _{p-p}	1
Lock Time (Asynchronous Switch)	t_{LOCK}	$T_A = 25^\circ C$, 500m of Belden 1694A	–	560	–	us	2
Serial Digital Input							
Serial Input Data Rate	DR_{SDI}	–	–	270	–	Mb/s	–
DVB-ASI Payload Data Rate	DR_{ASI}	204 byte mode	–	–	213.9	Mb/s	3,5
		188 byte mode	–	–	213.7	Mb/s	4,5
Achievable Cable Length	–	Belden 1694A Cable 270MHz	–	500	–	m	–
Input Return Loss	–	–	15	–	–	dB	6
Input Capacitance	–	single ended	–	1	–	pF	–
Parallel Output							
Parallel Output Clock Frequency	f_{PCLK}	–	–	27	–	MHz	–
Parallel Output Clock Duty Cycle	DC_{PCLK}	–	40	–	60	%	–
Variation of Parallel Output Clock (from 27MHz)	–	Device Unlocked $T_A = 5^\circ C$ to $45^\circ C$	-7	–	+7	%	7
Output Data Hold Time	t_{OH}	With 15pF load	3.0	–	–	ns	8
Output Delay Time	t_{OD}	With 15pF load	–	–	10.0	ns	8
GSPI							
GSPI Input Clock Frequency	f_{GSPI}	–	–	–	54.0	MHz	–
GSPI Clock Duty Cycle	DC_{GSPI}	–	40	–	60	%	–
GSPI Setup Time	t_{GS}	–	1.5	–	–	ns	–

Table 2-3: AC Electrical Characteristics (Continued)

$V_{DD} = 1.8V \pm 5\%$, $3.3V \pm 5\%$; $T_A = 0^\circ C$ to $70^\circ C$, unless otherwise specified. Typical values: $V_{CC} = 1.8V$, $3.3V$ and $T_A = 25^\circ C$

Parameter	Symbol	Condition	Min	Typ	Max	Units	Notes
GSPI Hold Time	t_{GH}	–	1.5	–	–	ns	–

NOTES

- 0m cable length.
- Time from input no-data to data switch and LOCKED pin set HIGH.
- Transmission format includes 204 byte data packets preceded by two K28.5 synchronization characters. Payload data rate excludes the two K28.5 synchronization characters.
- Transmission format includes 188 byte data packets preceded by two K28.5 synchronization characters. Payload data rate excludes the two K28.5 synchronization characters.
- Maximum payload is achieved via data packet mode, however, any combination of burst and packet mode is supported as long as each byte or packet is preceded by two K28.5 characters.
- 5MHz to 270MHz.
- When the serial input to the GS9091B is removed, the PCLK output signal will continue to operate at 27MHz and the internal VCO will remain at this frequency within +/-7% over the range $5^\circ C$ to $45^\circ C$. Over the full operating temperature range ($0^\circ C$ to $70^\circ C$), the VCO may deviate from 27MHz up to +/-13%.
- Timing includes the following outputs: DOUT[9:0], H, V, F, ANC, EDH_DETECT, FIFO_FULL, FIFO_EMPTY, $\overline{FIFO_LD}$, WORDERR, SYNCOUT. When the FIFO is enabled, the outputs are measured with respect to RD_CLK.

2.3 Solder Reflow Profiles

The device is manufactured with Matte-Sn terminations and is compatible with both standard eutectic and Pb-free solder reflow profiles. MSL qualification was performed using the maximum Pb-free reflow profile shown in Figure 2-1. The recommended standard eutectic reflow profile is shown in Figure 2-2.

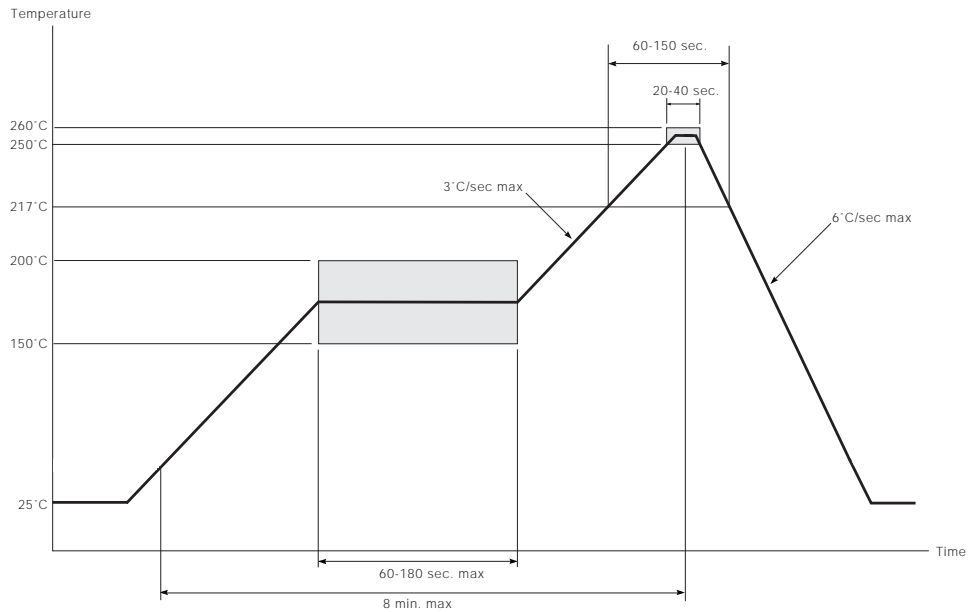

Figure 2-1: Maximum Pb-free Solder Reflow Profile (Preferred)

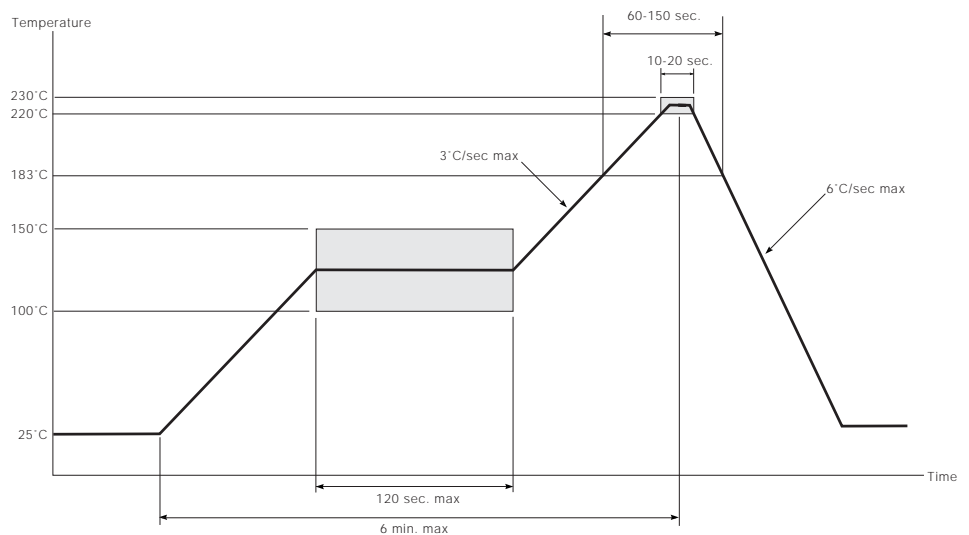

Figure 2-2: Standard Eutectic Solder Reflow Profile

2.4 Host Interface Map

Table 2-4: Host Interface Map

Register Name	Address	15	14	13	12	11	10	9	8	7	6	5	4	3	2	1	0
FIFO_ID_POSITION[12:0]	28h	Not Used	Not Used	Not Used	b12	b11	b10	b9	b8	b7	b6	b5	b4	b3	b2	b1	b0
27h																	
28h																	
ERROR_MASK_REGISTER	25h	Not Used	Not Used	Not Used	Not Used	Not Used	Not Used	Not Used	Not Used	Not Used	VD_STD_ERR_MASK	FF_CRC_ERR_MASK	AP_CRC_ERR_MASK	LOOK_ERR_MASK	CGS_ERR_MASK	SAV_ERR_MASK	EAV_ERR_MASK
FF_PIXEL_END_F[12:0]	24h	Not Used	Not Used	Not Used	b12	b11	b10	b9	b8	b7	b6	b5	b4	b3	b2	b1	b0
FF_PIXEL_START_F[12:0]	23h	Not Used	Not Used	Not Used	b12	b11	b10	b9	b8	b7	b6	b5	b4	b3	b2	b1	b0
FF_PIXEL_END_F0[12:0]	22h	Not Used	Not Used	Not Used	b12	b11	b10	b9	b8	b7	b6	b5	b4	b3	b2	b1	b0
FF_PIXEL_START_F0[12:0]	21h	Not Used	Not Used	Not Used	b12	b11	b10	b9	b8	b7	b6	b5	b4	b3	b2	b1	b0
AP_PIXEL_END_F[12:0]	20h	Not Used	Not Used	Not Used	b12	b11	b10	b9	b8	b7	b6	b5	b4	b3	b2	b1	b0
AP_PIXEL_START_F[12:0]	1Fh	Not Used	Not Used	Not Used	b12	b11	b10	b9	b8	b7	b6	b5	b4	b3	b2	b1	b0
AP_PIXEL_END_F0[12:0]	1Eh	Not Used	Not Used	Not Used	b12	b11	b10	b9	b8	b7	b6	b5	b4	b3	b2	b1	b0
AP_PIXEL_START_F0[12:0]	1Dh	Not Used	Not Used	Not Used	b12	b11	b10	b9	b8	b7	b6	b5	b4	b3	b2	b1	b0
FF_LINE_END_F[10:0]	1Ch	Not Used	Not Used	Not Used	Not Used	Not Used	b10	b9	b8	b7	b6	b5	b4	b3	b2	b1	b0
FF_LINE_START_F[10:0]	1Bh	Not Used	Not Used	Not Used	Not Used	Not Used	b10	b9	b8	b7	b6	b5	b4	b3	b2	b1	b0
FF_LINE_END_F0[10:0]	1Ah	Not Used	Not Used	Not Used	Not Used	Not Used	b10	b9	b8	b7	b6	b5	b4	b3	b2	b1	b0
FF_LINE_START_F0[10:0]	19h	Not Used	Not Used	Not Used	Not Used	Not Used	b10	b9	b8	b7	b6	b5	b4	b3	b2	b1	b0
AP_LINE_END_F[10:0]	18h	Not Used	Not Used	Not Used	Not Used	Not Used	b10	b9	b8	b7	b6	b5	b4	b3	b2	b1	b0
AP_LINE_START_F[10:0]	17h	Not Used	Not Used	Not Used	Not Used	Not Used	b10	b9	b8	b7	b6	b5	b4	b3	b2	b1	b0
AP_LINE_END_F0[10:0]	16h	Not Used	Not Used	Not Used	Not Used	Not Used	b10	b9	b8	b7	b6	b5	b4	b3	b2	b1	b0
AP_LINE_START_F0[10:0]	15h	Not Used	Not Used	Not Used	Not Used	Not Used	b10	b9	b8	b7	b6	b5	b4	b3	b2	b1	b0
RASTER_STRUCTURE[4:10:0]	14h	Not Used	Not Used	Not Used	Not Used	Not Used	b10	b9	b8	b7	b6	b5	b4	b3	b2	b1	b0
RASTER_STRUCTURE[3:12:0]	13h	Not Used	Not Used	Not Used	b12	b11	b10	b9	b8	b7	b6	b5	b4	b3	b2	b1	b0

Table 2-4: Host Interface Map (Continued)

Register Name	Address	15	14	13	12	11	10	9	8	7	6	5	4	3	2	1	0
RASTER_STRUCTURE2[12:0]	12h	Not Used	Not Used	Not Used	b12	b11	b10	b9	b8	b7	b6	b5	b4	b3	b2	b1	b0
RASTER_STRUCTURE[1:0:0]	11h	Not Used	Not Used	Not Used	Not Used	Not Used	b10	b9	b8	b7	b6	b5	b4	b3	b2	b1	b0
VIDEO_FORMAT_OUT_B[4:3]	10h	VFO4-b7	VFO4-b6	VFO4-b5	VFO4-b4	VFO4-b3	VFO4-b2	VFO4-b1	VFO4-b0	VFO3-b7	VFO3-b6	VFO3-b5	VFO3-b4	VFO3-b3	VFO3-b2	VFO3-b1	VFO3-b0
VIDEO_FORMAT_OUT_A[2:1]	0fh	VFO2-b7	VFO2-b6	VFO2-b5	VFO2-b4	VFO2-b3	VFO2-b2	VFO2-b1	VFO2-b0	VFO1-b7	VFO1-b6	VFO1-b5	VFO1-b4	VFO1-b3	VFO1-b2	VFO1-b1	VFO1-b0
ANC_TYPE[5]:[15:0]	0eh	b15	b14	b13	b12	b11	b10	b9	b8	b7	b6	b5	b4	b3	b2	b1	b0
ANC_TYPE[4]:[15:0]	0dh	b15	b14	b13	b12	b11	b10	b9	b8	b7	b6	b5	b4	b3	b2	b1	b0
ANC_TYPE[3]:[15:0]	0ch	b15	b14	b13	b12	b11	b10	b9	b8	b7	b6	b5	b4	b3	b2	b1	b0
ANC_TYPE[2]:[15:0]	0bh	b15	b14	b13	b12	b11	b10	b9	b8	b7	b6	b5	b4	b3	b2	b1	b0
ANC_TYPE[1]:[15:0]	0ah	b15	b14	b13	b12	b11	b10	b9	b8	b7	b6	b5	b4	b3	b2	b1	b0
ANC_LINE_B[10:0]	09h	Not Used	Not Used	Not Used	Not Used	Not Used	b10	b9	b8	b7	b6	b5	b4	b3	b2	b1	b0
ANC_LINE_A[10:0]	08h	Not Used	Not Used	Not Used	Not Used	Not Used	b10	b9	b8	b7	b6	b5	b4	b3	b2	b1	b0
FIFO_FULL_OFFSET	07h	Not Used	Not Used	Not Used	Not Used	Not Used	Not Used	b9	b8	b7	b6	b5	b4	b3	b2	b1	b0
FIFO_EMPTY_OFFSET	06h	Not Used	Not Used	Not Used	Not Used	ANC_DATA_DELETE	Not Used	b9	b8	b7	b6	b5	b4	b3	b2	b1	b0
IO_CONFIG	05h	Not Used	Not Used	Not Used	ANC_DATA_SWITCH	STAT3_CONFIG_t2	STAT3_CONFIG_b1	STAT3_CONFIG_b0	EDH_DETECT	STAT2_CONFIG_b1	STAT2_CONFIG_b0	STAT1_CONFIG_b2	STAT1_CONFIG_b1	STAT1_CONFIG_b0	STAT1_CONFIG_b1	STAT1_CONFIG_b0	STAT0_CONFIG_b0
DATA_FORMAT	04h	Not Used	Not Used	Not Used	Not Used	EDH_FLAG_UPDATE	AP_CRC_V	FF_CRC_V	EDH_DETECT	VERSION_32M	Not Used	Not Used	STD_LOCK	DATA_FORMAT_b3	DATA_FORMAT_b2	DATA_FORMAT_b1	DATA_FORMAT_b0
EDH_FLAG_OUT	03h	Not Used	ANC-UES	ANC-IDA	ANC-IDH	ANC-EDA	ANC-EDH	FF-UES	FF-IDA	FF-IDH	FF-EDA	FF-EDH	AP-UES	AP-IDA	AP-IDH	AP-EDA	AP-EDH
EDH_FLAG_IN	02h	Not Used	ANC-UES_IN	ANC-IDA_IN	ANC-IDH_IN	ANC-EDA_IN	ANC-EDH_IN	FF-UES_N	FF-IDA_N	FF-IDH_N	FF-EDA_N	FF-EDH_N	AP-UES_N	AP-IDA_N	AP-IDH_N	AP-EDA_N	AP-EDH_N
ERROR_STATUS	01h	Not Used	Not Used	Not Used	Not Used	Not Used	Not Used	Not Used	Not Used	Not Used	VD_STD_ERR	FF_CRC_ERR	AP_CRC_ERR	LOCK_ERR	CCS_ERR	SAV_ERR	EAV_ERR
IOPROC_DISABLE	00h	Not Used	Not Used	Not Used	Not Used	Not Used	ANC_PKT_EXT	ANC_PKT_EXT_b1	FIFO_MODE_b1	FIFO_MODE_b0	H_CONFIG	Not Used	Not Used	ILLEGAL_REMAP	EDH_CR_C_INS	ANC_CSUM_INS	TR_IN

NOTE: Addresses 02Ch to 42Bh store the contents of the internal FIFO. The contents may be accessed in Ancillary Data Extraction mode (see Section 3.10.3).

2.4.1 Host Interface Map (R/W registers)

Table 2-5: Host Interface Map (R/W registers)

Register Name	Address	15	14	13	12	11	10	9	8	7	6	5	4	3	2	1	0
FFO_LD_POSITION[12:0]	28h			b12	b11	b10	b9	b8	b7	b6	b5	b4	b3	b2	b1	b0	
ERROR_MASK_REGISTER	25h										VD_STD_ERR_MASK	FF_ORC_ERR_MASK	AP_ORC_ERR_MASK	LOCK_ERR_MASK	CCS_ERR_MASK	SAV_ERR_MASK	EA_V_ERR_MASK
FF_PIXEL_END_F0[12:0]	24h			b12	b11	b10	b9	b8	b7	b6	b5	b4	b3	b2	b1	b0	
FF_PIXEL_START_F1[12:0]	23h			b12	b11	b10	b9	b8	b7	b6	b5	b4	b3	b2	b1	b0	
FF_PIXEL_END_F0[12:0]	22h			b12	b11	b10	b9	b8	b7	b6	b5	b4	b3	b2	b1	b0	
FF_PIXEL_START_F0[12:0]	21h			b12	b11	b10	b9	b8	b7	b6	b5	b4	b3	b2	b1	b0	
AP_PIXEL_END_F1[12:0]	20h			b12	b11	b10	b9	b8	b7	b6	b5	b4	b3	b2	b1	b0	
AP_PIXEL_START_F1[12:0]	1Fh			b12	b11	b10	b9	b8	b7	b6	b5	b4	b3	b2	b1	b0	
AP_PIXEL_END_F0[12:0]	1Eh			b12	b11	b10	b9	b8	b7	b6	b5	b4	b3	b2	b1	b0	
AP_PIXEL_START_F0[12:0]	1Dh			b12	b11	b10	b9	b8	b7	b6	b5	b4	b3	b2	b1	b0	
FF_LINE_END_F1[10:0]	1Ch					b10	b9	b8	b7	b6	b5	b4	b3	b2	b1	b0	
FF_LINE_START_F1[10:0]	1Bh					b10	b9	b8	b7	b6	b5	b4	b3	b2	b1	b0	
FF_LINE_END_F0[10:0]	1Ah					b10	b9	b8	b7	b6	b5	b4	b3	b2	b1	b0	
FF_LINE_START_F0[10:0]	19h					b10	b9	b8	b7	b6	b5	b4	b3	b2	b1	b0	
AP_LINE_END_F1[10:0]	18h					b10	b9	b8	b7	b6	b5	b4	b3	b2	b1	b0	
AP_LINE_START_F1[10:0]	17h					b10	b9	b8	b7	b6	b5	b4	b3	b2	b1	b0	
AP_LINE_END_F0[10:0]	16h					b10	b9	b8	b7	b6	b5	b4	b3	b2	b1	b0	
AP_LINE_START_F0[10:0]	15h					b10	b9	b8	b7	b6	b5	b4	b3	b2	b1	b0	
	14h																
	13h																
	12h																

Table 2-5: Host Interface Map (R/W registers) (Continued)

Register Name	Address	15	14	13	12	11	10	9	8	7	6	5	4	3	2	1	0
	1h																
	10h																
	0Fh																
ANC_TYPE(5)[15:0]	0Eh	b15	b14	b13	b12	b11	b10	b9	b8	b7	b6	b5	b4	b3	b2	b1	b0
ANC_TYPE(4)[15:0]	0Dh	b15	b14	b13	b12	b11	b10	b9	b8	b7	b6	b5	b4	b3	b2	b1	b0
ANC_TYPE(3)[15:0]	0Ch	b15	b14	b13	b12	b11	b10	b9	b8	b7	b6	b5	b4	b3	b2	b1	b0
ANC_TYPE(2)[15:0]	0Bh	b15	b14	b13	b12	b11	b10	b9	b8	b7	b6	b5	b4	b3	b2	b1	b0
ANC_TYPE(1)[15:0]	0Ah	b15	b14	b13	b12	b11	b10	b9	b8	b7	b6	b5	b4	b3	b2	b1	b0
ANC_LINE_B[10:0]	09h						b10	b9	b8	b7	b6	b5	b4	b3	b2	b1	b0
ANC_LINE_A[10:0]	08h						b10	b9	b8	b7	b6	b5	b4	b3	b2	b1	b0
FIFO_FULL_OFFSET	07h							b9	b8	b7	b6	b5	b4	b3	b2	b1	b0
FIFO_EMPTY_OFFSET	06h					ANC_DATA_DELETE		b9	b8	b7	b6	b5	b4	b3	b2	b1	b0
IO_CONFIG	05h			ANC_DATA_SWITCH	STAT3_CONFIG	STAT3_CONFIG	STAT3_CONFIG	STAT3_CONFIG	STAT2_CONFIG	STAT2_CONFIG	STAT2_CONFIG	STAT1_CONFIG	STAT1_CONFIG	STAT1_CONFIG	STAT0_CONFIG	STAT0_CONFIG	STAT0_CONFIG
DATA_FORMAT	04h					EDH_FLAG_UPDATE											
	03h																
	02h																
	01h																
IOPROC_DISABLE	00h					ANC_PKT_EXT			FIFO_MODE	FIFO_MODE	H_CONFIG			ILLEGAL_REMAP	EDH_CR_C_INS	ANC_CSUML_INS	TRF_IN

NOTE: Addresses 02Ch to 42Bh store the contents of the internal FIFO. The contents may be accessed in Ancillary Data Extraction mode (see Section 3.10.3).

2.4.2 Host Interface Map (Read only registers)

Table 2-6: Host Interface Map (Read only registers)

Register Name	Address	15	14	13	12	11	10	9	8	7	6	5	4	3	2	1	0
	28h																
	27h																
	26h																
	25h																
	24h																
	23h																
	22h																
	21h																
	20h																
	1Fh																
	1Eh																
	1Dh																
	1Ch																
	1Bh																
	1Ah																
	19h																
	18h																
	17h																
	16h																
	15h																
RASTER_STRUCTURE4[100]	14h			b10			b6	b6	b6	b7	b6	b5	b4	b3	b2	b1	b0
RASTER_STRUCTURE3[120]	13h				b12	b11	b10	b9	b8	b7	b6	b5	b4	b3	b2	b1	b0
RASTER_STRUCTURE2[120]	12h					b11	b10	b9	b8	b7	b6	b5	b4	b3	b2	b1	b0
RASTER_STRUCTURE1[100]	11h						b10	b9	b8	b7	b6	b5	b4	b3	b2	b1	b0

Table 2-6: Host Interface Map (Read only registers) (Continued)

Register Name	Address	15	14	13	12	11	10	9	8	7	6	5	4	3	2	1	0
VIDEO_FORMAT_OUT_B(4:3)	10h	VFO4-b7	VFO4-b6	VFO4-b5	VFO4-b4	VFO4-b3	VFO4-b2	VFO4-b1	VFO4-b0	VFO3-b7	VFO3-b6	VFO3-b5	VFO3-b4	VFO3-b3	VFO3-b2	VFO3-b1	VFO3-b0
VIDEO_FORMAT_OUT_A(2:1)	0Fh	VFO2-b7	VFO2-b6	VFO2-b5	VFO2-b4	VFO2-b3	VFO2-b2	VFO2-b1	VFO2-b0	VFO1-b7	VFO1-b6	VFO1-b5	VFO1-b4	VFO1-b3	VFO1-b2	VFO1-b1	VFO1-b0
	0Eh																
	0Dh																
	0Ch																
	0Bh																
	0Ah																
	09h																
	08h																
	07h																
	06h																
	05h																
DATA_FORMAT	04h						AP_CRC_V	FF_CRC_V	EDH_DETECT	VERSION_352M			STD_LOCK	DATA_FORMAT_b3	DATA_FORMAT_b2	DATA_FORMAT_b1	DATA_FORMAT_b0
EDH_FLAG_OUT	03h	Not Used	ANC_UES	ANC_IDA	ANC_IDH	ANC_EDA	ANC_EDH	FF_UES	FF_IDA	FF_IDH	FF_EDA	FF_EDH	AP_UES	AP_IDA	AP_IDH	AP_EDA	AP_EDH
EDH_FLAG_IN	02h	Not Used	ANC_UES_IN	ANC_IDA_IN	ANC_IDH_IN	ANC_EDA_IN	ANC_EDH_IN	FF_UES_N	FF_IDA_IN	FF_IDH_N	FF_EDA_N	FF_EDH_N	AP_UES_N	AP_IDA_N	AP_IDH_N	AP_EDA_N	AP_EDH_N
ERROR_STATUS	01h										VD_STD_ERR	FF_CRC_ERR	AP_CRC_ERR	LOCK_ERR	CCS_ERR	SAV_ERR	EAV_ERR
	00h																

NOTE: Addresses 02Ch to 42Bh store the contents of the internal FIFO. The contents may be accessed in Ancillary Data Extraction mode (see Section 3.10.3).

3. Detailed Description

- [Functional Overview](#)
- [Cable Equalization](#)
- [Clock and Data Recovery](#)
- [Serial-To-Parallel Conversion](#)
- [Modes Of Operation](#)
- [SMPTE Functionality](#)
- [DVB-ASI Functionality](#)
- [Data-Through Functionality](#)
- [Additional Processing Features](#)
- [Internal FIFO Operation](#)
- [Parallel Data Outputs](#)
- [Programmable Multi-Function Outputs](#)
- [GS9091B Low-latency Mode](#)
- [GSPI Host Interface](#)
- [JTAG operation](#)
- [Device Power Up](#)

3.1 Functional Overview

The GS9091B is a 270Mb/s equalizing and reclocking deserializer with an internal FIFO and programmable multi-function output port. The device has two basic modes of operation. In Auto mode, the GS9091B can automatically detect SMPTE or DVB-ASI data streams at its input. In Manual mode, the device can be set to process SMPTE or DVB/ASI data streams.

The digital signal processing core handles ancillary data detection/indication, error detection and handling (EDH), SMPTE352M extraction, and automatic video standards detection. These features are all enabled by default, but may be individually disabled via internal registers accessible through the GSPI host interface.

The provided programmable multi-function output pins may be configured to output various status signals including H, V, and F timing, ancillary data detection, EDH detection, and a FIFO load pulse. The internal FIFO supports 4 modes of operation, which may be used for data alignment, data delay, MPEG packet extraction, or ancillary data extraction.

The GS9091B contains a JTAG interface for boundary scan test implementations.

3.2 Cable Equalization

The input signal passes through a variable gain equalizing stage whose frequency response closely matches the inverse of the cable loss characteristic.

The serial data signal may be connected to the input pins ($\overline{\text{SDI}}/\overline{\text{SDI}}$) in either a differential or single ended configuration. AC coupling of the inputs is recommended, as the SDI and $\overline{\text{SDI}}$ inputs are internally biased at approximately 1.8V.

The cable equalization block is powered by the EQ_VDD and EQ_GND pins. The cable equalizer can be bypassed by setting the EQ_BYPASS pin HIGH.

3.3 Clock and Data Recovery

The GS9091B contains an integrated clock and data recovery block. The function of this block is to lock to the input data stream, extract a clean clock, and retime the serial digital data to remove high frequency jitter. The operating centre frequency of the reclocker is 270Mb/s.

3.3.1 Internal VCO and Phase Detector

The GS9091B uses an internal VCO and PFD as part of the reclocker's phase-locked loop. Each block requires a +1.8V DC power supply, which is supplied via the VCO_VDD / VCO_GND and PLL_VDD / PLL_GND pins.

3.4 Serial-To-Parallel Conversion

The function of this block is to extract 10-bit parallel data words from the reclocked serial data stream and simultaneously present them to the SMPTE and DVB-ASI word alignment blocks.

3.5 Modes Of Operation

The GS9091B has two basic modes of operation: Auto mode and Manual mode. Auto mode is enabled when $\overline{\text{AUTO/MAN}}$ is set HIGH, and Manual mode is enabled when $\overline{\text{AUTO/MAN}}$ is set LOW. As indicated in [Figure 3-1](#), each mode supports both SMPTE and DVB-ASI input signals. In addition, Data-Through functionality is possible when the GS9091B is in Manual mode.

In Auto mode ($\overline{\text{AUTO/MAN}} = \text{HIGH}$), the GS9091B will automatically detect, equalize, reclock, deserialize, and process SMPTE 259M-C, or DVB-ASI input data.

In Manual mode ($\overline{\text{AUTO/MAN}} = \text{LOW}$), the $\overline{\text{SMPTE_BYPASS}}$ and DVB_ASI pins must be set as per [Table 3-2](#) for the correct reception of either SMPTE or DVB-ASI data. Manual mode also supports the equalizing, reclocking and deserializing of 270Mb/s data not conforming to SMPTE or DVB-ASI streams.

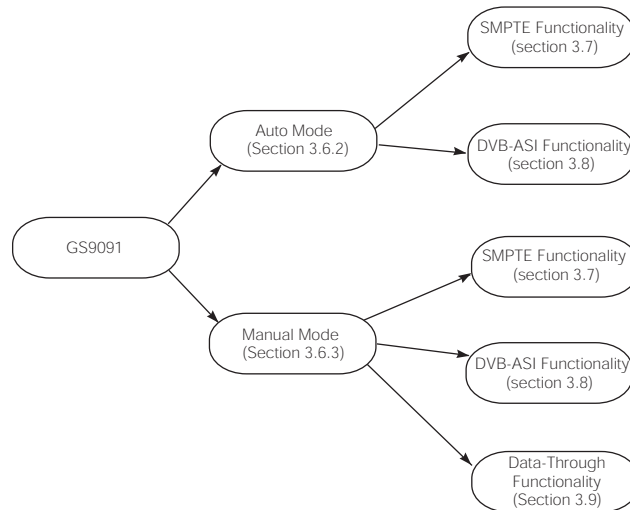

Figure 3-1: GS9091B's Modes of Operation

3.5.1 Lock Detect

Once the reclocker has locked to the received serial digital data stream, the lock detect block of the GS9091B searches for the appropriate sync words, and indicates via the LOCKED output pin when the device has successfully achieved lock. The LOCKED pin is designed to be stable. It will not toggle during the locking process, nor will it glitch during a SMPTE synchronous switch.

The lock detection process is summarized in [Figure 3-2](#).

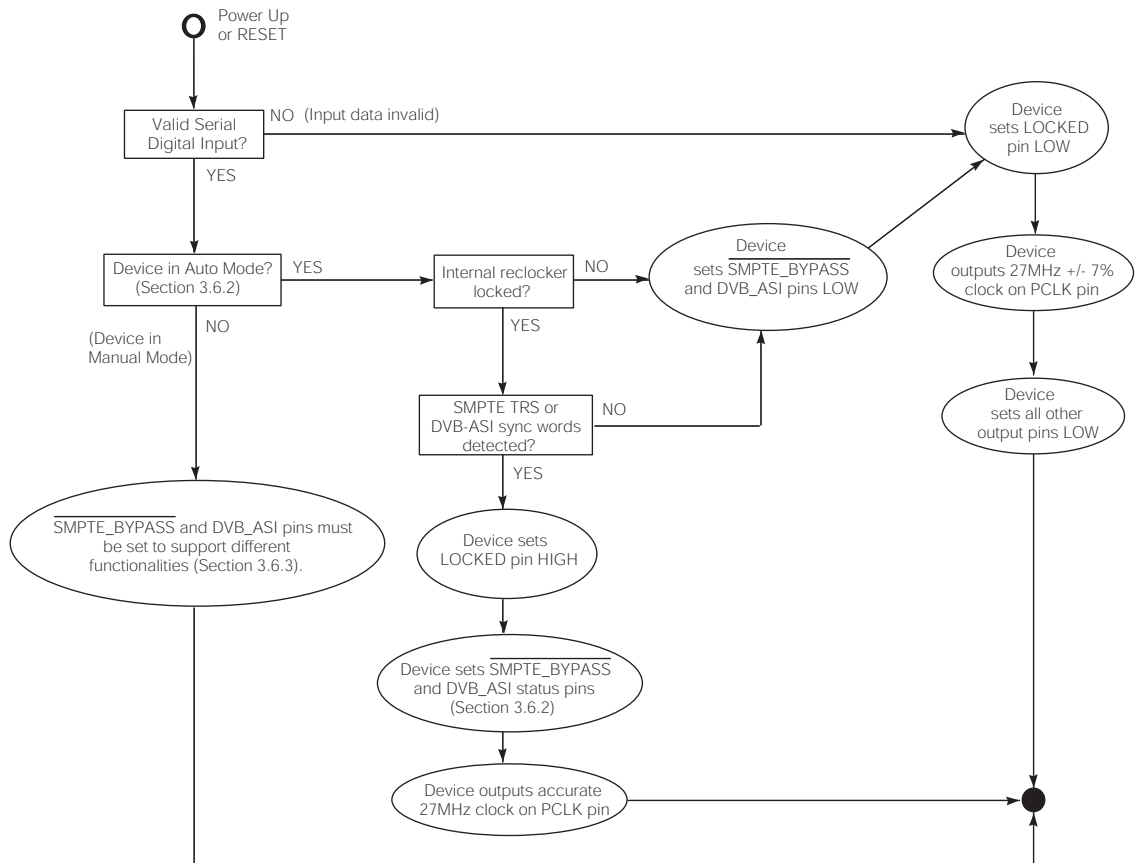

Figure 3-2: Lock Detection Process

The lock detection algorithm (Figure 3-2) first determines if the input is a 270Mb/s serial digital data stream.

When the serial data input signal is considered invalid, the LOCKED pin will be set LOW, and all device outputs will be forced LOW, except PCLK.

If a valid serial digital input signal has been detected, and the device is in Auto mode, the lock algorithm will attempt to detect the presence of either SMPTE TRS words or DVB-ASI sync words*. Assuming that a valid 270Mb/s SMPTE or DVB-ASI signal has been applied to the device, the LOCKED pin will be set HIGH.

* DVB-ASI sync words must be immediately followed by an MPEG packet header for word alignment to correctly function.

For serial inputs that do not conform to SMPTE or DVB-ASI formats, the device can only achieve the locked state in manual mode. In Auto mode, the LOCKED signal will be asserted LOW, the parallel outputs will be latched to logic LOW, and the $\overline{\text{SMPTE_BYPASS}}$ and $\overline{\text{DVB_ASI}}$ output signals will also be set LOW.

In Manual mode, the $\overline{\text{SMPTE_BYPASS}}$ and $\overline{\text{DVB_ASI}}$ input pins must be set LOW. If the GS9091B achieves lock to the input data signal, data will be passed directly to the parallel outputs without any further processing (see [Section 3.8](#)).

3.5.2 Auto Mode

The GS9091B is in Auto mode when the $\overline{\text{AUTO/MAN}}$ input pin is set HIGH. In this mode, $\overline{\text{SMPTE_BYPASS}}$ and $\overline{\text{DVB_ASI}}$ become output status pins, as shown in [Table 3-1](#).

Table 3-1: Auto Mode Output Status Signals

Format	Pin Settings	
	$\overline{\text{SMPTE_BYPASS}}$	$\overline{\text{DVB_ASI}}$
SD SMPTE	HIGH	LOW
DVB-ASI	LOW	HIGH
NOT SMPTE OR DVB-ASI*	LOW	LOW

*NOTE: In this case the device will not be locked (LOCKED = LOW), and all digital output pins except PCLK will be set LOW (see [Section 3.5.1](#))

3.5.3 Manual Mode

The GS9091B is in Manual mode when the $\overline{\text{AUTO/MAN}}$ input pin is set LOW. In this mode, the $\overline{\text{SMPTE_BYPASS}}$ and $\overline{\text{DVB_ASI}}$ pins become input signals, and the operating mode of the device is set by these pins as shown in [Table 3-2](#)

Table 3-2: Manual Mode Input Status Signals

Format	Pin Settings	
	$\overline{\text{SMPTE_BYPASS}}$	$\overline{\text{DVB_ASI}}$
SD SMPTE	HIGH	LOW
DVB-ASI	X	HIGH
NOT SMPTE OR DVB-ASI (Data-Through mode)*	LOW	LOW

*NOTE: See [Section 3.8](#) for more detail on Data-Through mode

3.6 SMPTE Functionality

The GS9091B is in SMPTE mode once the device has detected two SMPTE TRS sync words. The GS9091B will remain in SMPTE mode until six SMPTE TRS sync words fail to be detected.

TRS word detection is a continuous process, and the device will identify both 8-bit and 10-bit TRS words.

In Auto mode, the GS9091B sets the $\overline{\text{SMPTE_BYPASS}}$ pin HIGH and the DVB_ASI pin LOW to indicate that it has locked to a SMPTE input data stream. When operating in Manual mode, the DVB_ASI pin must be set LOW and the SMPTE_BYPASS pin must be set HIGH in order to enable SMPTE operation.

3.6.1 SMPTE Descrambling and Word Alignment

The GS9091B performs NRZI-to-NRZ decoding, descrambling according to SMPTE 259M-C, and word alignment of the data to the TRS sync words when in SMPTE mode.

NOTE: When 8-bit data is embedded into the SMPTE signal, the source must have the two LSBs of the 10-bit stream set to logic LOW in order for word alignment to function correctly.

3.6.2 Internal Flywheel

The GS9091B has an internal flywheel for the generation of internal / external timing signals, the detection and correction of certain error conditions, and the automatic detection of video standards. The flywheel is only operational in SMPTE mode.

The flywheel 'learns' the video standard by timing the horizontal and vertical reference information contained in the TRS ID words of the received video stream. The flywheel maintains information about the total line length, active line length, total number of lines per field / frame, and total active lines per field / frame for the received video stream. Full synchronization of the flywheel to the received video standard therefore requires one complete video frame.

Once synchronization has been achieved, the flywheel will continue to monitor the received TRS timing information to maintain synchronization.

The FW_EN input pin controls the synchronization mechanism of the flywheel. When this input signal is LOW, the flywheel will re-synchronize all pixel and line based counters on every received TRS ID word.

When FW_EN is set to logic HIGH, re-synchronization occurs when the flywheel detects three to four consecutive video lines containing mistimed TRS information. This provides a measure of noise immunity to internal and external timing signal generation.

The flywheel will be disabled if the device loses lock, or a LOW-to-HIGH transition occurs on the $\overline{\text{RESET}}$ pin.

3.6.3 Switch Line Lock Handling

The principle of switch line lock handling is that the switching of synchronous video sources will only disturb the horizontal timing and alignment of the stream, whereas the vertical timing remains in synchronization.

3.6.3.1 Automatic Switch Line Lock Handling

The GS9091B also implements automatic switch line lock handling. By utilizing both the synchronous switch point defined in SMPTE RP168, and the automatic video standards detect function, the device automatically re-synchronizes the flywheel at the switch point. This will occur whether or not the device has detected TRS word errors. Word alignment re-synchronization will also take place at this time.

Automatic switch line lock handling will occur regardless of the setting of the FW_EN pin.

The switch line is defined as follows:

- for 525 line interlaced systems: re-sync takes place at the end of lines 10 & 273
- for 625 line interlaced systems: re-sync takes place at the end of lines 6 & 319

A full list of 270Mb/s video standards and switching lines is shown in [Table 3-3](#).

At every PCLK cycle the device samples the FW_EN pin. When the FW_EN pin is set LOW anywhere within the active line, the flywheel will re-synchronize immediately to the next TRS word.

3.6.3.2 Manual Switch Line Lock Handling

The ability to manually re-synchronize the flywheel is also important when switching asynchronous sources or to implement other non-standardized video switching functions.

To account for the horizontal disturbance caused by a synchronous switch, it is necessary to re-synchronize the flywheel immediately after the switch has taken place. Rapid re-synchronization of the GS9091B to the new video standard can be achieved by disabling the flywheel (setting the FW_EN pin to logic LOW) after the switch, and re-enabling the flywheel after the next TRS word.

Table 3-3: Switch Line Position for 270MB/s Digital Systems

System	Video Format	Sampling	Signal Standard	Parallel Interface	Serial Interface	Switch Line Number
SDTI	720x576/50 (2:1)	4:2:2	BT.656	BT.656 + 305M	259M-C	6, 319
	720x483/59.94 (2:1)	4:2:2	125M	125M + 305M	259M-C	10, 273
525	720x483/59.94 (2:1)	4:2:2	125M	125M	259M-C	10, 273
625	720x576/50 (2:1)	4:2:2	BT.656	125M	259M-C	6, 319

3.6.4 HVF Timing Signal Generation

The GS9091B extracts timing parameters, and outputs them to the F, V and H pins, from either the received TRS signals (FW_EN = LOW) or from the internal flywheel-timing generator (FW_EN = HIGH).

Horizontal blanking period (H), vertical blanking period (V), and field odd / even timing (F) are extracted and are available for output on any of the multi-function output port pins, if so programmed (see Section 3.12).

The H signal timing is configurable via the H_CONFIG bit of the internal IOPROC_DISABLE register as either active line-based blanking, or TRS-based blanking (see Table 3-14 in Section 3.9.8).

Active line-based blanking is enabled when the H_CONFIG bit is set LOW. In this mode, the H output is HIGH for the entire horizontal blanking period, including the EAV and SAV TRS words. This is the default H timing used by the device.

When H_CONFIG is set HIGH, TRS based blanking is enabled. In this case, the H output will be HIGH for the entire horizontal blanking period as indicated by the H bit in the received TRS ID words.

The timing of these signals is shown in Figure 3-3.

NOTE 1: When the internal FIFO is configured for video mode, the H, V, and F signals will be timed to the data output from the FIFO (see Section 3.10.1).

NOTE 2: When the GS9091B is configured for Low-latency mode, the H, V, and F output timing will be TRS-based as shown in Section 3.13. Active line-based timing is not available in this mode, and the setting of the H_CONFIG host interface bit will be ignored.

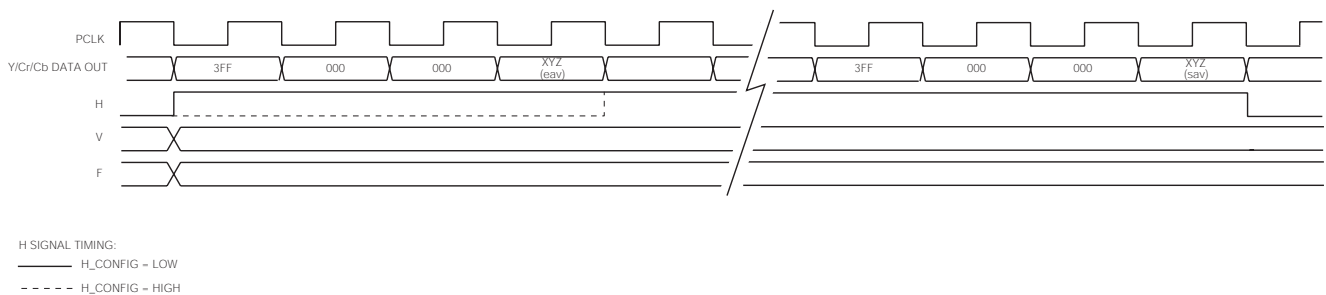

Figure 3-3: H,V,F Timing

3.7 DVB-ASI Functionality

The GS9091B is said to be in DVB-ASI mode once the device has detected 32 consecutive DVB-ASI words without a single word or disparity error being generated. The device will remain in DVB-ASI mode until 32 consecutive DVB-ASI word errors or disparity errors are detected

K28.5 sync patterns in the received DVB-ASI data stream will be detected by the device in either inverted or non-inverted form.

In Auto mode, the GS9091B sets the $\overline{\text{SMPTE_BYPASS}}$ pin LOW and the DVB_ASI pin HIGH to indicate that it has locked to a DVB-ASI input data stream. When operating in Manual mode, the DVB_ASI pin must be set to logic HIGH in order to enable DVB-ASI operation. The $\overline{\text{SMPTE_BYPASS}}$ pin will be ignored.

When using DVB-ASI mode, the use of application circuit in [Figure 3-4 on page 31](#) is suggested. The use of this application circuit will prevent the internal PLL from false locking to a DVB-ASI signal harmonic rather than the 270MHz fundamental. This application circuit will detect the false lock state and restart the on-chip PLL. The application circuit does this by detecting if the LOCK has been de-asserted for longer than $\sim 700\mu\text{s}$, and if so resets the PLL by discharging the loop filter capacitor through a CMOS switch.

The applications circuit below show how this can be implemented by using a STG719 switch as a reference. Other low leakage CMOS switches may also be substituted within the circuit.

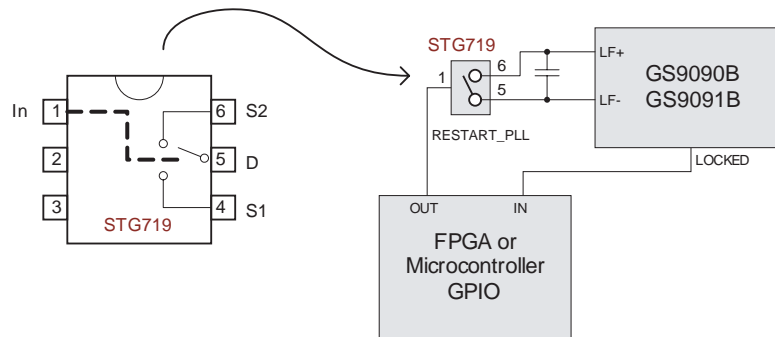

Figure 3-4: GS9091B False Lock Restart Circuit

The circuit above can be implemented using either a small state machine in an FPGA or general purpose I/O on a microcontroller in combination with some firmware. Typically, a system using the GS9091B will have an existing FPGA and/or microcontroller that may have some spare I/O that can be used to implement the false lock restart circuit. The choice of method will depend on what spare system resources are available. In either case, the waveform shown in [Figure 3-5 on page 32](#) represents how the PLL restart must be driven. The delay values of $700\mu\text{s}$ and $20\mu\text{s}$ are nominal but the values can be longer. In the case where the SDI inputs are not driven with a valid DVB-ASI signal, the RESTART_PLL signal should be repeated indefinitely as long as LOCKED remains de-asserted.

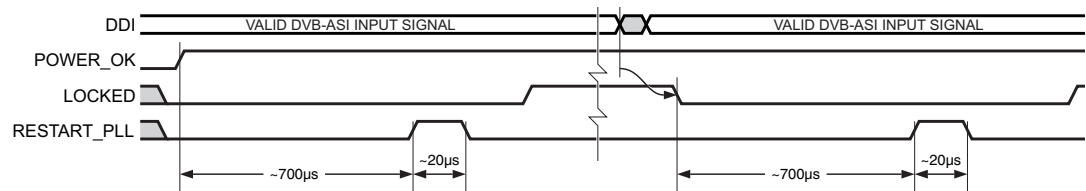

Figure 3-5: GS9091B False Lock Restart Circuit Waveforms of False Lock After Power-up and False Lock After a Signal Switch.

3.7.1 DVB-ASI 8b/10b Decoding

The GS9091B will word align the data to the K28.5 sync characters, and 8b/10b decode and bit-swap the data to achieve bit alignment with the data outputs.

NOTE: DVB-ASI sync words must be immediately followed by an MPEG packet header for word alignment to correctly function.

The extracted 8-bit data will be presented to DOUT [7:0], bypassing all internal SMPTE mode data processing.

3.7.2 Status Signal Outputs

In DVB-ASI mode, the DOUT9 and DOUT8 pins will be configured as DVB-ASI status signals WORDERR and SYNCOUT respectively.

SYNCOUT will be HIGH whenever a K28.5 sync character is present on the output. WORDERR will be HIGH whenever the device has detected an illegal 8b/10b code word or there is a running disparity error.

3.8 Data-Through Functionality

The GS9091B may be configured to operate as a simple serial-to-parallel converter. In this mode, the data is output to the parallel output without performing any decoding, descrambling, or word-alignment.

Data-Through functionality is enabled when the $\overline{\text{AUTO/MAN}}$, $\overline{\text{SMPTE_BYPASS}}$, and $\overline{\text{DVB_ASI}}$ input pins are set to logic LOW. Under these conditions, the GS9091B allows 270Mb/s input data not conforming to SMPTE or DVB-ASI streams to be reclocked and deserialized. If the device is in Data-Through mode, and the reclocker locks to the data stream, the LOCKED pin will be representative of the serial digital input data frequency.

3.9 Additional Processing Features

The GS9091B contains additional processing features that are available in SMPTE mode only (see [Section 3.6](#)).

3.9.1 FIFO Load Pulse

To aid in the implementation of auto-phasing and line synchronization functions, the GS9091B will generate a FIFO load pulse to reset line-based FIFO storage. This FIFO_LD signal is available for output on one of the multi-function output port pins, if so programmed (see [Section 3.12](#)).

The FIFO_LD pulse is an active LOW signal which will assert LOW for one PCLK period, generating a FIFO write reset signal. This signal is co-timed to the SAV XYZ code word present on the output data bus. This ensures that the next PCLK cycle will correspond with the first active sample of the video line.

NOTE: When the internal FIFO of the GS9091B is set to operate in video mode, the FIFO_LD pulse can be used to drive the RD_RESET input to the device (see [Section 3.10.1](#)).

[Figure 3-6](#) shows the default timing relationship between the FIFO_LD signal and the output video data.

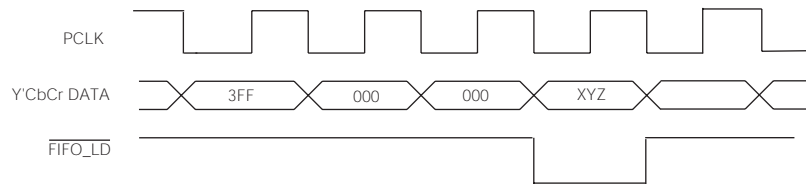

Figure 3-6: FIFO_LD Pulse Timing

3.9.1.1 Programmable FIFO Load Position

The position of the FIFO_LD pulse can be moved in PCLK increments from its default position at the SAV XYZ code word to a maximum of one full line from the default position. The offset number of PCLK's must be programmed in the FIFO_LD_POSITION[12:0] internal register (address 28h), via the host interface.

The FIFO_LD_POSITION[12:0] register is designed to accommodate the longest SD line length. If a value greater than the maximum line length at the operating SD standard is programmed in this register, the FIFO_LD pulse will not be generated.

After a device reset, the FIFO_LD_POSITION[12:0] register is set to zero and the FIFO_LD pulse will assume the default timing.

3.9.2 Ancillary Data Detection and Indication

The GS9091B will detect all types of ancillary data in either the vertical or horizontal data spaces. The ANC status signal is provided to indicate the position of ancillary data in the output data stream. This signal is available for output on the multi-function output port pins (see [Section 3.12](#)).

The ANC status signal is synchronous with PCLK and can be used as a clock enable to external logic, or as a write enable to an external FIFO or other memory device. The ANC signal will be asserted HIGH whenever ancillary data is detected in the video data stream (see [Figure 3-7](#)). Both 8-bit and 10-bit ancillary data preambles will be detected by the GS9091B.

NOTE: When the internal FIFO is configured for video mode, the ANC signal will be timed to the data output from the FIFO (see [Section 3.10.1](#)).

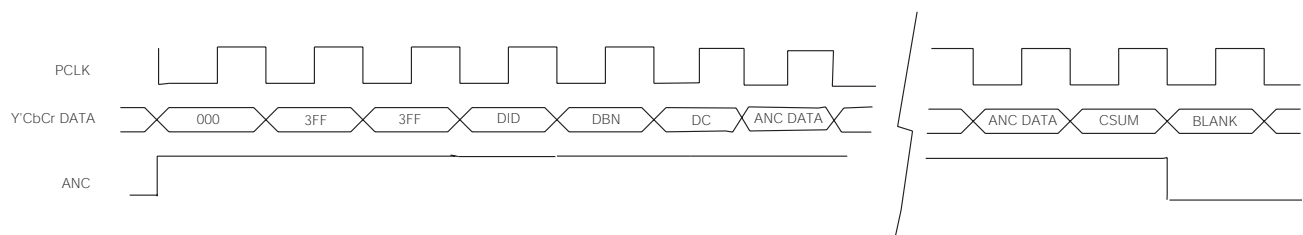

Figure 3-7: ANC Status Signal

3.9.2.1 Programmable Ancillary Data Detection

The GS9091B will detect all types of ancillary data by default. In addition, up to five different ancillary data types can be programmed for detection. This is accomplished by programming the ANC_TYPE registers with the DID and/or SDID values, via the host interface, for each data type to be detected (see [Table 3-4](#)).

The GS9091B will compare the received DID and/or SDID with the programmed values and assert ANC only if an exact match is found.

If the DID or SDID values are set to zero in the ANC_TYPE register, a comparison or match for that codeword will not be made. For example, if the DID is programmed but the SDID is set to zero, the device will detect all ancillary data types matching the DID value, regardless of the SDID. If both DID and SDID values are non-zero, then the received ancillary data type must match both the DID and SDID cases before the device will assert ANC HIGH.

In the case where all five DID and SDID values are set to zero, the GS9091B will detect all ancillary data types. This is the default setting after a device reset.

If greater than one, but less than five, DID and/or SDID values have been programmed, then only those matching ancillary data types will be detected and indicated.

NOTE: See SMPTE 291M for a definition of ancillary data terms.

Table 3-4: Host Interface Description for Programmable Ancillary Data Type registers

Register Name	Bit	Name	Description	R/W	Default
ANC_TYPE 1 Address: 0Ah	15-8	ANC_TYPE1[15:8]	Used to program the DID for ancillary data detection at ANC output	R/W	0
	7-0	ANC_TYPE1[7:0]	Used to program the SDID for ancillary data detection at ANC output. Should be set to zero if no SDID is present in the ancillary data packet to be detected.	R/W	0
ANC_TYPE 2 Address: 0Bh	15-8	ANC_TYPE2[15:8]	Used to program the DID for ancillary data detection at ANC output	R/W	0
	7-0	ANC_TYPE2[7:0]	Used to program the SDID for ancillary data detection at ANC output. Should be set to zero if no SDID is present in the ancillary data packet to be detected.	R/W	0
ANC_TYPE 3 Address: 0Ch	15-8	ANC_TYPE3[15:8]	Used to program the DID for ancillary data detection at ANC output	R/W	0
	7-0	ANC_TYPE3[7:0]	Used to program the SDID for ancillary data detection at ANC output. Should be set to zero if no SDID is present in the ancillary data packet to be detected.	R/W	0
ANC_TYPE 4 Address: 0Dh	15-8	ANC_TYPE4[15:8]	Used to program the DID for ancillary data detection at ANC output	R/W	0
	7-0	ANC_TYPE4[7:0]	Used to program the SDID for ancillary data detection at ANC output. Should be set to zero if no SDID is present in the ancillary data packet to be detected.	R/W	0
ANC_TYPE 5 Address: 0Eh	15-8	ANC_TYPE5[15:8]	Used to program the DID for ancillary data detection at ANC output	R/W	0
	7-0	ANC_TYPE5[7:0]	Used to program the SDID for ancillary data detection at ANC output. Should be set to zero if no SDID is present in the ancillary data packet to be detected.	R/W	0

3.9.3 EDH Packet Detection

The GS9091B will determine if EDH packets are present in the incoming video data and assert the EDH_DETECT output status signal appropriately.

EDH_DETECT will be set HIGH when EDH packets have been detected and will remain HIGH until EDH packets are no longer present. The signal will be set LOW at the end of the vertical blanking (falling edge of V) if an EDH packet has not been received and detected during vertical blanking.

EDH_DETECT can be programmed to be available for output on the multi-function output port pins (see [Section 3.12](#)). The EDH_DETECT bit is also available in the DATA_FORMAT register at address 04h (see [Table 3-7](#)).

3.9.4 EDH Flag Detection

As described in [Section 3.9.3](#), the GS9091B can detect EDH packets in the received data stream. The EDH flags for ancillary data, active picture, and full field areas are extracted from the detected EDH packets and placed in the EDH_FLAG_IN register at address 02h ([Table 3-5](#)).

When the EDH_FLAG_UPDATE bit in the DATA_FORMAT register 04h ([Table 3-7](#)) is set HIGH, the GS9091B will update the ancillary data, full field, and active picture EDH flags according to SMPTE RP165. The updated EDH flags are available in the EDH_FLAG_OUT register at address 03h ([Table 3-6](#)). The EDH packet output from the device will contain the updated flags.

One set of flags is provided for both fields 1 and 2. Field 1 flag data will be overwritten by field 2 flag data.

When EDH packets are not detected, the UES flags in the EDH_FLAG_OUT register will be set HIGH to signify that the received signal does not support Error Detection and Handling. In addition, the EDH_DETECT bit will be set LOW. These flags are set regardless of the setting of the EDH_FLAG_UPDATE bit.

EDH_FLAG_OUT and EDH_FLAG_UPDATE may be read by the host interface at any time during the received frame except on the lines defined in SMPTE RP165, where these flags are updated.

The GS9091B will indicate the CRC validity for both active picture and full field CRCs. The AP_CRC_V bit in the DATA_FORMAT register indicates the active picture CRC validity, and the FF_CRC_V bit indicates the full field CRC validity (see [Table 3-7](#)). When EDH_DETECT = LOW, these bits will be cleared.

The EDH_FLAG_OUT and EDH_FLAG_UPDATE register values remain set until overwritten by the decoded flags in the next received EDH packet in the following field. When an EDH packet is not detected during vertical blanking, the flag registers will be cleared at the end of the vertical blanking period.

Table 3-5: Host Interface Description for EDH Flag Registers

Register Name	Bit	Name	Description	R/W	Default
EDH_FLAG_IN Address: 02h	15	–	Not Used	–	–
	14	ANC-UES_IN	Ancillary Unknown Error Status Flag	R	0
	13	ANC-IDA_IN	Ancillary Internal device error Detected Already Flag.	R	0
	12	ANC-IDH_IN	Ancillary Internal device error Detected Here Flag.	R	0
	11	ANC-EDA_IN	Ancillary Error Detected Already Flag.	R	0
	10	ANC-EDH_IN	Ancillary Error Detected Here Flag.	R	0
	9	FF-UES_IN	Full Field Unknown Error Status Flag.	R	0
	8	FF-IDA_IN	Full Field Internal device error Detected Already Flag.	R	0
	7	FF-IDH_IN	Full Field Internal device error Detected Here Flag.	R	0
	6	FF-EDA_IN	Full Field Error Detected Already Flag.	R	0
	5	FF-EDH_IN	Full Field Error Detected Here Flag.	R	0
	4	AP-UES_IN	Active Picture Unknown Error Status Flag.	R	0
	3	AP-IDA_IN	Active Picture Internal device error Detected Already Flag.	R	0
	2	AP-IDH_IN	Active Picture Internal device error Detected Here Flag	R	0
	1	AP-EDA_IN	Active Picture Error Detected Already Flag.	R	0
	0	AP-EDH_IN	Active Picture Error Detected Here Flag.	R	0

Table 3-6: Host Interface Description for EDH Flag Registers

Register Name	Bit	Name	Description	R/W	Default
EDH_FLAG_OUT Address: 03h	15	–	Not Used	–	–
	14	ANC-UES	Ancillary Unknown Error Status Flag	R	0
	13	ANC-IDA	Ancillary Internal device error Detected Already Flag.	R	0
	12	ANC-IDH	Ancillary Internal device error Detected Here Flag.	R	0
	11	ANC-EDA	Ancillary Error Detected Already Flag.	R	0
	10	ANC-EDH	Ancillary Error Detected Here Flag.	R	0
	9	FF-UES	Full Field Unknown Error Status Flag.	R	0
	8	FF-IDA	Full Field Internal device error Detected Already Flag.	R	0
	7	FF-IDH	Full Field Internal device error Detected Here Flag.	R	0
	6	FF-EDA	Full Field Error Detected Already Flag.	R	0
	5	FF-EDH	Full Field Error Detected Here Flag.	R	0
	4	AP-UES	Active Picture Unknown Error Status Flag.	R	0
	3	AP-IDA	Active Picture Internal device error Detected Already Flag.	R	0
	2	AP-IDH	Active Picture Internal device error Detected Here Flag	R	0
	1	AP-EDA	Active Picture Error Detected Already Flag.	R	0
	0	AP-EDH	Active Picture Error Detected Here Flag.	R	0

Table 3-7: Host Interface Description for Data Format Register

Register Name	Bit	Name	Description	R/W	Default
DATA_FORMAT Address: 04h	15-12	–	Not Used	–	–
	11	EDH_FLAG_UPDATE	When set HIGH by the application layer, the device will update the ancillary data, full field, and active picture EDH flags according to SMPTE RP165.	R/W	0
	10	AP_CRC_V	Active Picture CRC Valid bit.	R	0
	9	FF_CRC_V	Full Field CRC Valid bit.	R	0
	8	EDH_DETECT	Set HIGH by the device when EDH packets are detected in the incoming video data.	R	0
	7	VERSION_352M	Indicates whether decoded SMPTE 352M packet is version 0 or version 1. See Section 3.9.5 .	R	0
	6-5	–	Not Used	–	–
	4	STD_LOCK	Standard Lock bit. This bit will be set HIGH when the flywheel has achieved full synchronization to the received video standard. See Section 3.9.6 .	R	0
	3-0	DATA_FORMAT[3:0]	Displays the data format being carried on the serial digital interface. See Section 3.9.6.1 .	R	0

3.9.5 SMPTE 352M Payload Identifier

The GS9091B can receive and detect the presence of the SMPTE 352M payload identifier.

Upon detection of this packet, the device will extract the four words contained in the packet to the VIDEO_FORMAT_OUT_A and VIDEO_FORMAT_OUT_B registers at addresses 10h and 0fh ([Table 3-8](#)). The device will also indicate the version of the payload packet in bit 7 of the DATA_FORMAT register ([Table 3-7](#)). When bit 7 is set HIGH the received SMPTE 352M packet is version 1, otherwise it is version 0.

The VIDEO_FORMAT registers will only be updated if the received checksum is the same as the locally calculated checksum.

If the device loses lock to the input data stream (LOCKED = LOW), or if the SMPTE_BYPASS pin is asserted LOW, the VIDEO_FORMAT_OUT_A and VIDEO_FORMAT_OUT_B registers will be cleared to zero, indicating an undefined format. This is also the default setting after a device reset.

Table 3-8: Host Interface Description for SMPTE 352M Payload Identifier Registers

Register Name	Bit	Name	Description	R/W	Default
VIDEO_FORMAT_OUT_B Address: 10h	15-8	SMPTE 352M Byte 4	Data will be available in this register when Video Payload Identification Packets are detected in the data stream.	R	0
	7-0	SMPTE 352M Byte 3	Data will be available in this register when Video Payload Identification Packets are detected in the data stream.	R	0
VIDEO_FORMAT_OUT_A Address: 0Fh	15-8	SMPTE 352M Byte 2	Data will be available in this register when Video Payload Identification Packets are detected in the data stream.	R	0
	7-0	SMPTE 352M Byte 1	Data will be available in this register when Video Payload Identification Packets are detected in the data stream.	R	0

3.9.6 Automatic Video Standard and Data Format Detection

The GS9091B can detect the input video standard and data format by using the timing parameters extracted from the received TRS ID. Total samples per line, active samples per line, total lines per frame, and active lines per field are all calculated and presented to the host interface via the RASTER_STRUCTURE registers (Table 3-9).

Also associated with the RASTER_STRUCTURE registers is the STD_LOCK status bit. The GS9091B will set STD_LOCK HIGH when the flywheel has achieved full synchronization to the received video standard. STD_LOCK is stored in the DATA_FORMAT register (Table 3-7).

The four RASTER_STRUCTURE registers, as well as the STD_LOCK status bit will default to zero after a device reset, or if the device loses lock to the input data stream (LOCKED = LOW).

Table 3-9: Host Interface Description for Raster Structure Registers

Register Name	Bit	Name	Description	R/W	Default
RASTER_STRUCTURE1 Address: 11h	15-11	–	Not Used	–	–
	10-0	RASTER_STRUCTURE1[10:0]	Total Lines Per Frame	R	0
RASTER_STRUCTURE2 Address: 12h	15-13	–	Not Used	–	–
	12-0	RASTER_STRUCTURE2[12:0]	Total Words Per Line	R	0
RASTER_STRUCTURE3 Address: 13h	15-13	–	Not Used	–	–
	12-0	RASTER_STRUCTURE3[12:0]	Words Per Active Line	R	0
RASTER_STRUCTURE4 Address: 14h	15-11	–	Not Used	–	–
	10-0	RASTER_STRUCTURE4[10:0]	Active Lines Per Field	R	0

3.9.6.1 Data Format Indication

The GS9091B can extract the data format being carried on the serial digital interface (i.e. SDTI, SDI, or DVB-ASI). This information is represented by bits 0 to 3 of the DATA_FORMAT register (Table 3-7).

DATA_FORMAT[3:0] register codes are shown in Table 3-10.

The DATA_FORMAT[3:0] register defaults to Fh (undefined) after a system reset. The register will also be set to its default value if the device is not locked (LOCKED = LOW), or if both $\overline{\text{SMPTE_BYPASS}}$ and DVB_ASI pins are LOW.

Table 3-10: Data Format Register Codes

Data Format[3:0]	Data Format	Applicable Standards
0h	SDTI DVCPRO - No ECC	SMPTE 321M
1h	SDTI DVCPRO - ECC	SMPTE 321M
2h	SDTI DVCAM	SMPTE 322M
3h	SDTI CP	SMPTE 326M
4h	Other SDTI fixed block size	–
5h	Other SDTI variable block size	–
6h	SDI	–
7h	DVB-ASI	–
8h ~ Eh	Reserved	–
Fh	Unknown data format	–

3.9.7 Error Detection and Indication

The GS9091B contains a number of error detection functions to enhance operation of the device when operating in SMPTE mode. These functions, except lock error detection, will not be available in DVB-ASI mode (Section 3.7) or Data-Through mode (Section 3.8).

The ERROR_STATUS register is at address 01h (Table 3-11). All bits, except the LOCK_ERR bit, will be cleared at the start of each video field or when read by the host interface, whichever condition occurs first.

All bits, with the exception of the LOCK_ERR, will also be cleared if a change in the video standard is detected, if the device loses lock to the input data stream (LOCKED = LOW), or if the $\overline{\text{SMPTE_BYPASS}}$ pin is asserted LOW.

The ERROR_STATUS register, including the LOCK_ERR bit, will be set LOW during a system reset ($\overline{\text{RESET}}$ = LOW).

The ERROR_MASK register (Table 3-12) is available to individually mask each error type in the ERROR_STATUS register. Each error type may be individually masked by setting its corresponding bit HIGH. The bits of the ERROR_MASK register will default to '0' after a device reset, thus allowing all error types to be detected.

The $\overline{\text{DATA_ERROR}}$ signal pin indicates the status of the ERROR_STATUS register. This output pin is an inverted logical OR of each error status flag stored in the ERROR_STATUS register. $\overline{\text{DATA_ERROR}}$ will be set LOW by the device when an error condition that has not been masked is detected.

Table 3-11: Host Interface Description for Error Status Register

Register Name	Bit	Name	Description	R/W	Default
ERROR_STATUS Address: 01h	15-7	–	Not Used	–	–
	6	VD_STD_ERR	Video Standard Error Flag. Set HIGH when a mismatch between the received SMPTE 352M packets (version 1 or version 0) and the calculated video standard occurs.	R	0
	5	FF_CRC_ERR	Full Field CRC Error Flag. Set HIGH when a Full Field (FF) CRC mismatch has been detected in Field 1 or 2	R	0
	4	AP_CRC_ERR	Active Picture CRC Error Flag. Set HIGH when an Active Picture (AP) CRC mismatch has been detected in Field 1 or 2.	R	0
	3	LOCK_ERR	Lock Error Flag. Set HIGH whenever the LOCKED pin is LOW (indicating the device is not correctly locked).	R	0
	2	CS_ERR	Checksum Error Flag. Set HIGH when ancillary data packet checksum error has been detected.	R	0
	1	SAV_ERR	Start of Active Video Error Flag. Set HIGH when TRS errors are detected in either 8-bit or 10-bit TRS words.	R	0
	0	EAV_ERR	End of Active Video Error Flag. Set HIGH when TRS errors are detected in either 8-bit or 10-bit TRS words.	R	0

Table 3-12: Host Interface Description for Error Mask Register

Register Name	Bit	Name	Description	R/W	Default
ERROR_MASK Address: 25h	15-7	–	Not Used	–	–
	6	VD_STD_ERR_MASK	Video Standard Error Flag Mask bit.	R/W	0
	5	FF_CRC_ERR_MASK	Full Field CRC Error Flag Mask bit.	R/W	0
	4	AP_CRC_ERR_MASK	Active Picture CRC Error Flag Mask bit	R/W	0
	3	LOCK_ERR_MASK	Lock Error Flag Mask bit.	R/W	0
	2	CS_ERR_MASK	Checksum Error Flag Mask bit.	R/W	0
	1	SAV_ERR_MASK	Start of Active Video Error Flag Mask bit.	R/W	0
	0	EAV_ERR_MASK	End of Active Video Error Flag Mask bit.	R/W	0

3.9.7.1 Video Standard Error Detection

If a mismatch between the decoded SMPTE 352M packets and the calculated video standard occurs, the GS9091B will indicate a video standard error by setting the VD_STD_ERR bit of the ERROR_STATUS register HIGH. The device will detect errors in both version 1 and version 0 352M packets.

3.9.7.2 EDH CRC Error Detection

The GS9091B calculates the Full Field (FF) and Active Picture (AP) CRC words according to SMPTE RP165 in support of Error Detection and Handling packets in SD signals.

These calculated CRC values are compared with the received CRC values. If a mismatch is detected, the error is flagged in the AP_CRC_ERR and/or FF_CRC_ERR bits of the ERROR_STATUS register. These two flags are shared between fields 1 and 2.

The AP_CRC_ERR bit will be set HIGH when an active picture CRC value mismatch has been detected in field 1 or 2. The FF_CRC_ERR bit will be set HIGH when a full field CRC value mismatch has been detected in field 1 or 2.

EDH CRC errors will only be indicated when the device has correctly received EDH packets.

SMPTE RP165 specifies the calculation ranges and scope of EDH data for standard 525 and 625 component digital interfaces. The GS9091B will utilize these standard ranges by default.

If the received video format does not correspond to 525 or 625 digital component video standards as determined by the flywheel pixel and line counters, the ranges will be based on the line and pixel ranges programmed by the host interface. In the absence of user-programmed calculation ranges, the ranges will be determined from the received TRS timing information.

The registers available to the host interface for programming EDH calculation ranges include active picture and full field line/pixel start and end positions for both fields (Table 3-13). These registers default to '0' after a device reset.

If any or all of these register values are zero, then the EDH CRC calculation ranges will be determined from the flywheel generated timing. The first active and full field pixel will always be the first pixel after the SAV TRS code word. The last active and full field pixel will always be the last pixel before the start of the EAV TRS code words.

Table 3-13: Host Interface Description for EDH Calculation Range Registers

Register Name	Bit	Name	Description	R/W	Default
AP_LINE_START_F0 Address: 15h	15-11	–	Not Used	–	–
	10-0	AP_LINE_START_F0[10:0]	Field 0 Active Picture start line data used to set EDH calculation range outside of SMPTE RP 165 values.	R/W	0
AP_LINE_END_F0 Address: 16h	15-11	–	Not Used	–	–
	10-0	AP_LINE_END_F0[10:0]	Field 0 Active Picture end line data used to set EDH calculation range outside of SMPTE RP 165 values.	R/W	0
AP_LINE_START_F1 Address: 17h	15-11	–	Not Used	–	–
	10-0	AP_LINE_START_F1[10:0]	Field 1 Active Picture start line data used to set EDH calculation range outside of SMPTE RP 165 values.	R/W	0
AP_LINE_END_F1 Address: 18h	15-11	–	Not Used	–	–
	10-0	AP_LINE_END_F1[10:0]	Field 1 Active Picture end line data used to set EDH calculation range outside of SMPTE RP 165 values.	R/W	0
FF_LINE_START_F0 Address: 19h	15-11	–	Not Used	–	–
	10-0	FF_LINE_START_F0[10:0]	Field 0 Full Field start line data used to set EDH calculation range outside of SMPTE RP 165 values.	R/W	0
FF_LINE_END_F0 Address: 1Ah	15-11	–	Not Used	–	–
	10-0	FF_LINE_END_F0[10:0]	Field 0 Full Field end line data used to set EDH calculation range outside of SMPTE RP 165 values.	R/W	0
FF_LINE_START_F1 Address: 1Bh	15-11	–	Not Used	–	–
	10-0	FF_LINE_START_F1[10:0]	Field 1 Full Field start line data used to set EDH calculation range outside of SMPTE RP 165 values.	R/W	0
FF_LINE_END_F1 Address: 1Ch	15-11	–	Not Used	–	–
	10-0	FF_LINE_END_F1[10:0]	Field 1 Full Field end line data used to set EDH calculation range outside of SMPTE RP 165 values.	R/W	0

Table 3-13: Host Interface Description for EDH Calculation Range Registers (Continued)

Register Name	Bit	Name	Description	R/W	Default
AP_PIXEL_START_F0 Address: 1Dh	15-13	–	Not Used	–	–
	12-0	AP_PIXEL_START_F0[12:0]	Field 0 Active Picture start pixel data used to set EDH calculation range outside of SMPTE RP 165 values.	R/W	0
AP_PIXEL_END_F0 Address: 1Eh	15-13	–	Not Used	–	–
	12-0	AP_PIXEL_END_F0[12:0]	Field 0 Active Picture end pixel data used to set EDH calculation range outside of SMPTE RP 165 values.	R/W	0
AP_PIXEL_START_F1 Address: 1Fh	15-13	–	Not Used	–	–
	12-0	AP_PIXEL_START_F1[12:0]	Field 1 Active Picture start pixel data used to set EDH calculation range outside of SMPTE RP 165 values.	R/W	0
AP_PIXEL_END_F1 Address: 20h	15-13	–	Not Used	–	–
	12-0	AP_PIXEL_END_F1[12:0]	Field 1 Active Picture end pixel data used to set EDH calculation range outside of SMPTE RP 165 values.	R/W	0
FF_PIXEL_START_F0 Address: 21h	15-13	–	Not Used	–	–
	12-0	FF_PIXEL_START_F0[12:0]	Field 0 Full Field start pixel data used to set EDH calculation range outside of SMPTE RP 165 values.	R/W	0
FF_PIXEL_END_F0 Address: 22h	15-13	–	Not Used	–	–
	12-0	FF_PIXEL_END_F0[12:0]	Field 0 Full Field end pixel data used to set EDH calculation range outside of SMPTE RP 165 values.	R/W	0
FF_PIXEL_START_F1 Address: 23h	15-13	–	Not Used	–	–
	12-0	FF_PIXEL_START_F1[12:0]	Field 1 Full Field start pixel data used to set EDH calculation range outside of SMPTE RP 165 values.	R/W	0
FF_PIXEL_END_F1 Address: 24h	15-13	–	Not Used	–	–
	12-0	FF_PIXEL_END_F1[12:0]	Field 1 Full Field end pixel data used to set EDH calculation range outside of SMPTE RP 165 values.	R/W	0

3.9.7.3 Lock Error Detection

The LOCKED pin of the GS9091B asserts HIGH when the device has correctly locked to the received data stream (see [Section 3.5.1](#)).

The GS9091B will also indicate lock error to the host interface when LOCKED = LOW by setting the LOCK_ERR bit in the ERROR_STATUS register HIGH ([Table 3-11](#)).

3.9.7.4 Ancillary Data Checksum Error Detection

The GS9091B will calculate checksums for all received ancillary data types and compare the calculated values to the received checksum words. If a mismatch is detected, the CS_ERR bit of the ERROR_STATUS register will be set HIGH ([Table 3-11](#)).

Although the GS9091B will calculate and compare checksum values for all ancillary data types by default, the host interface may be programmed to check only certain types of ancillary data checksums, as described in [Section 3.9.2.1](#).

3.9.7.5 TRS Error Detection

TRS error flags are generated by the GS9091B when the received TRS H timing does not correspond to the internal flywheel timing, or when the received TRS Hamming codes are incorrect.

These errors are flagged via the SAV_ERR and/or EAV_ERR bits of the ERROR_STATUS register ([Table 3-11](#)). Both 8-bit and 10-bit SAV and EAV errors are handled by the GS9091B.

NOTE: H timing based TRS errors will only be detected if the FW_EN pin is set HIGH. F & V timing errors are not detected or corrected.

3.9.8 Additional SMPTE Mode Processing

The GS9091B contains an additional processing block which is available in SMPTE mode only. The IOPROC_EN pin must be set HIGH to enable these functions. These functions, which are all enabled by default, may be enabled or disabled individually by setting bits 0 to 3 in the IOPROC_DISABLE register ([Table 3-14](#)).

NOTE: After a device reset, these functions will revert to their default values.

Table 3-14: Host Interface Description for Internal Processing Disable Register

Register Name	Bit	Name	Description	R/W	Default
IOPROC_DISABLE Address: 00h	15-10	–	Not Used	–	–
	9	ANC_PKT_EXT	Ancillary Packet Extraction. When the FIFO is configured for Ancillary Data Extraction mode, the application layer must set this bit HIGH to begin extraction. NOTE: Setting ANC_PKT_EXT LOW will not automatically disable ancillary data extraction (see Section 3.10.3.1).	R/W	0
	8-7	FIFO_MODE[1:0]	FIFO Mode: These bits control which mode the internal FIFO is operating in (see Table 3-15)	R/W	0
	6	H_CONFIG	Horizontal sync timing output configuration. Set LOW for active line blanking timing. Set HIGH for H blanking based on the H bit setting of the TRS word. See Figure 3-3 in Section 3.6.4 .	R/W	0
	5-4		Not Used.		
	3	ILLEGAL_REMAP	Illegal Code re-mapping. Correction of illegal code words within the active picture. Set HIGH to disable. The IOPROC_EN pin must be set HIGH.	R/W	0
	2	EDH_CRC_INS	Error Detection & Handling (EDH) Cyclical Redundancy Check (CRC) error correction insertion. Set HIGH to disable. The IOPROC_EN pin must be set HIGH.	R/W	0
	1	ANC_CSUM_INS	Ancillary Data Checksum insertion. Set HIGH to disable. The IOPROC_EN pin must be set HIGH.	R/W	0
	0	TRS_INS	Timing Reference Signal Insertion. The device will correct TRS based errors when set LOW (see Section 3.9.8.4 TRS Error Correction). The IOPROC_EN pin must also be HIGH. Set this bit HIGH to disable.	R/W	0

3.9.8.1 Illegal Code Remapping

If the ILLEGAL_REMAP bit of the IOPROC_DISABLE register is set LOW, the GS9091B will remap all codes within the active picture between the values 3FCh and 3FFh to 3FBh. All codes within the active picture area between the values 00h and 03h will be re-mapped to 04h. In addition, 8-bit TRS and ancillary data preambles will be remapped to 10-bit values.

3.9.8.2 EDH CRC Error Correction

If the EDH_CRC_INS bit of the IOPROC_DISABLE register is set LOW, the GS9091B will calculate and overwrite the active picture and full field CRC words into the EDH data packets received by the device.

Additionally, when EDH_CRC_INS is LOW, the device will set the active picture and full field CRC 'V' bits HIGH in the EDH packet (see [Section 3.9.4](#)). The AP_CRC_V and FF_CRC_V register bits will only report the received EDH validity flags.

EDH CRC calculation ranges are described in [Section 3.9.7.2](#).

NOTE: Although the GS9091B will modify and insert EDH CRC words and EDH packet checksums, the device will only update EDH error flags when the EDH_FLAG_UPDATE bit is set HIGH (see [Section 3.9.4](#)).

3.9.8.3 Ancillary Data Checksum Error Correction

If the ANC_CSUM_INS bit of the IOPROC_DISABLE register is set LOW, ancillary checksum error correction and insertion is enabled, and the GS9091B will calculate and overwrite ancillary data checksums for all ancillary data words by default. If the Ancillary Data type has been specified in the ANC_TYPE registers of the host interface (see [Section 3.9.2.1](#)), only the checksums for the ancillary data programmed will be updated.

3.9.8.4 TRS Error Correction

If the TRS_INS bit of the IOPROC_DISABLE register is set LOW, TRS error correction and insertion is enabled. In this mode, the GS9091B will calculate and overwrite 10-bit TRS code words as required.

TRS code word generation will be performed using the timing parameters generated by the flywheel to provide an element of noise immunity, and will only take place if the flywheel is enabled (FW_EN = HIGH).

NOTE: Only H timing based errors will be corrected (see [Section 3.9.7.5 TRS Error Detection](#)).

3.10 Internal FIFO Operation

The GS9091B contains an internal video line-based FIFO, which can be programmed by the application layer to work in any of the following modes:

1. Video Mode,
2. DVB-ASI Mode,
3. Ancillary Data Extraction Mode, or
4. Bypass Mode

The FIFO can be configured to one of the four modes by using the host interface to set the FIFO_MODE[1:0] bits of the IOPROC_DISABLE register (see [Table 3-14](#) in [Section 3.9.8](#)). The setting of these bits is shown in [Table 3-15](#). To enable the FIFO, the FIFO_EN pin must be set HIGH. Additionally, if the FIFO is configured for video mode or ancillary data extraction mode, the IOPROC_EN pin must be set HIGH.

The FIFO is fully asynchronous, allowing simultaneous read and write access. It has a depth of 2048 words, which will accommodate 1 full line of SD video for both 525 and 625 standards. The FIFO is 15 bits wide: 10 bits for video data and 5 bits for other signals, such as H, V, F, EDH_DETECT, and ANC.

Table 3-15: FIFO Configuration Bit Settings

FIFO Mode	FIFO_MODE[1:0] Register Setting	FIFO_EN Pin Setting	IOPROC_EN Pin Setting
Video Mode	00b	HIGH	HIGH
DVB-ASI Mode	01b	HIGH	X
Ancillary Data Extraction Mode	10b	HIGH	HIGH
Bypass Mode	11b	X	X

NOTE: 'X' signifies 'don't care'. The pin is ignored and may be set HIGH or LOW.

3.10.1 Video Mode

The internal FIFO is in video mode when the FIFO_EN and IOPROC_EN pins are set HIGH, and the FIFO_MODE[1:0] bits in the IOPROC_DISABLE register are configured to 00b. By default, the FIFO_MODE[1:0] bits are set to 00b by the device whenever the SMPTE_BYPASS pin is set HIGH and the DVB_ASI pin is set LOW (i.e. the device is in SMPTE mode); however, the FIFO_MODE[1:0] bits may be programmed as required.

[Figure 3-8](#) shows the input and output signals of the FIFO when it is configured for video mode.

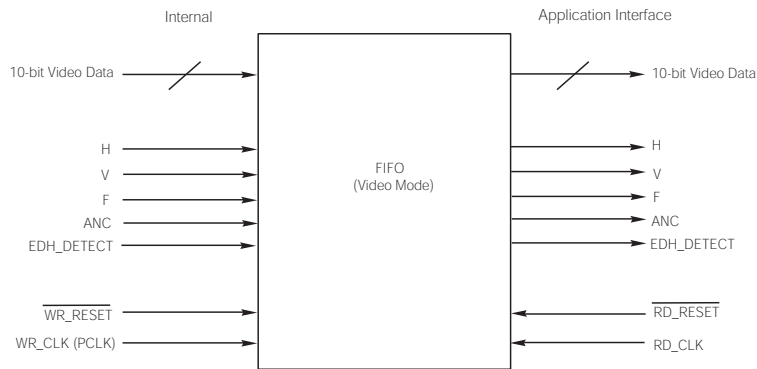

Figure 3-8: FIFO in Video Mode

When operating in video mode, the GS9091B will write data sequentially into the FIFO, starting with the first active pixel in location zero of the memory. In this mode, it is possible to use the FIFO for clock phase interchange and data alignment / delay. The extracted H, V, and F information will also be written into the FIFO. The H, V, and F outputs will be timed to the video data read from the FIFO (see [Section 3.6.4](#)).

The device will ensure write-side synchronization is maintained, according to the extracted PCLK and flywheel timing information.

Full read-control of the FIFO is made available such that data will be clocked out of the FIFO on the rising edge of the externally provided RD_CLK signal. When there is a HIGH-to-LOW transition at the RD_RESET pin, the first pixel presented to the video data bus will be the first 000 of the SAV (see [Figure 3-9](#)). The FIFO_LD pulse may be used to control the RD_RESET pin.

NOTE: The RD_RESET pulse should not be held LOW for more than one RD_CLK cycle.

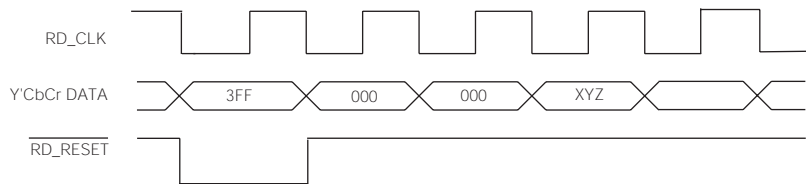

Figure 3-9: RD_RESET Pulse Timing

In video mode, the ANC output signal will be timed to the data output from the FIFO (see [Section 3.9.2](#) for more detail).

3.10.2 DVB-ASI Mode

The internal FIFO is in DVB-ASI mode when the FIFO_EN pin is set HIGH, and the FIFO_MODE[1:0] bits in the IOPROC_DISABLE register are configured to 01b. By default, the FIFO_MODE[1:0] bits are set to 01b by the device whenever the DVB_ASI pin is set HIGH (i.e. the device is in DVB-ASI mode); however, the FIFO_MODE[1:0] bits may be programmed as required.

Figure 3-10 shows the input and output signals of the FIFO when it is configured for DVB-ASI Mode.

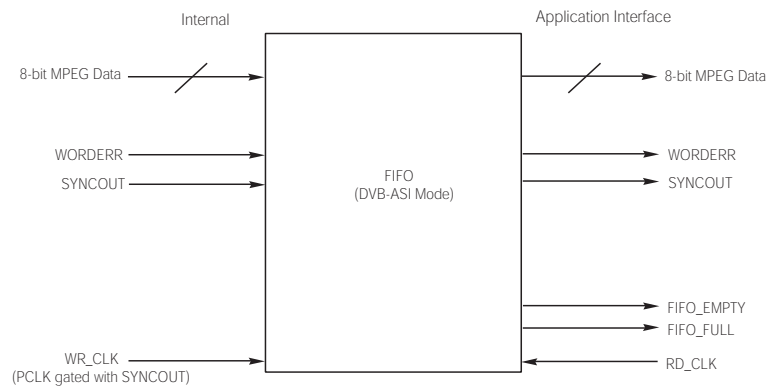

Figure 3-10: FIFO in DVB-ASI Mode

When operating in DVB-ASI mode, the GS9091B's FIFO can be used for clock rate interchange operation. The extracted 8-bit MPEG packets will be written into the FIFO at 27MHz based on the SYNCOUT signal from the internal DVB-ASI decoder block. The SYNCOUT and WORDERR bits are also stored in the FIFO (see [Section 3.7.2](#)).

When SYNCOUT goes HIGH, K28.5 stuffing characters have been detected and no data will be written into the FIFO.

Data is read out of the FIFO using the RD_CLK pin. In DVB-ASI mode, the $\overline{\text{RD_RESET}}$ pin is not used.

NOTE: With the internal FIFO enabled in DVB-ASI mode, SYNCOUT will always be LOW since the K28.5 sync characters are not stored in the FIFO.

3.10.2.1 Reading From the FIFO

The FIFO contains internal read and write pointers used to designate which spot in the FIFO the MPEG packet will be read from or written to. These internal pointers control the status flags FIFO_EMPTY and FIFO_FULL, which are available for output on the multi-function output port pins, if so programmed (see Section 3.12).

In the case where the write pointer is originally ahead of the read pointer, the FIFO_EMPTY flag will be set HIGH when both pointers arrive at the same address (see block A in Figure 3-12). This flag can be used to determine when to stop reading from the device.

A write and read pointer offset may be programmed in the FIFO_EMPTY_OFFSET[9:0] register of the host interface. If an offset value is programmed in this register, the FIFO_EMPTY flag will be set HIGH when the read and write pointers of the FIFO are at the same address, and will remain HIGH until the write pointer reaches the programmed offset. Once the pointer offset has been exceeded, the FIFO_EMPTY flag will go LOW (see block B in Figure 3-12).

In the case where the read pointer is originally ahead of the write pointer, the FIFO_FULL flag will be set HIGH when both pointers arrive at the same address (see block C in Figure 3-12). This flag can be used to determine when to begin reading from the device.

A read and write pointer offset may also be programmed in the FIFO_FULL_OFFSET[9:0] register of the host interface. If an offset value is programmed in this register, the FIFO_FULL flag will be set HIGH when the read and write pointers of the FIFO are at the same address, and will remain set HIGH until the read pointer reaches the programmed offset. Once the pointer offset has been exceeded, the FIFO_FULL flag will be cleared (see block D in Figure 3-12).

Gating the RD_CLK Using the FIFO_EMPTY Flag

Using the asynchronous FIFO_EMPTY flag to gate RD_CLK requires external clock gating circuitry. The recommended circuit for this application is shown in Figure 3-11.

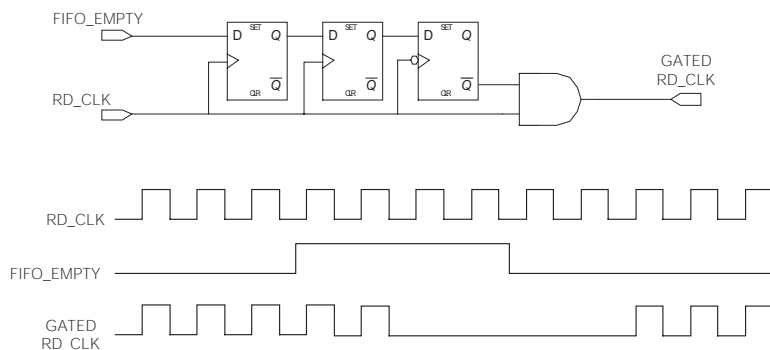

Figure 3-11: Recommended Circuit to Gate RD_CLK Using the FIFO_EMPTY Flag

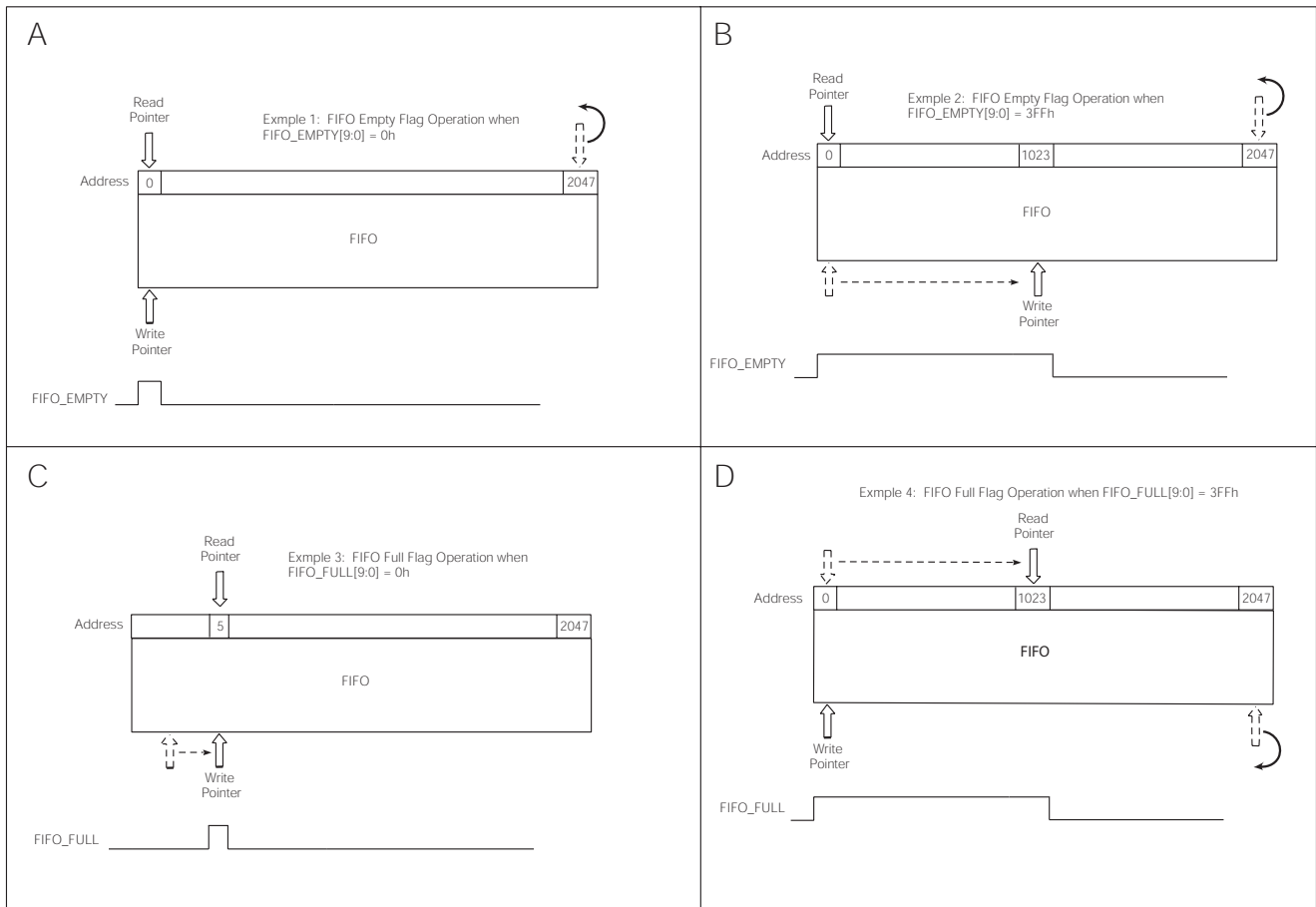

Figure 3-12: Reading From the FIFO in DVB-ASI Mode

3.10.3 Ancillary Data Extraction Mode

The internal FIFO is ancillary data extraction mode when the FIFO_EN and IOPROC_EN pins are set HIGH, and the FIFO_MODE[1:0] bits in the IOPROC_DISABLE register are configured to 10b.

Once the FIFO enters ancillary data extraction mode, it takes 2200 PCLKs (82us) to initialize the FIFO before ancillary data extraction can begin.

In this mode, the FIFO is divided into two separate blocks of 1024 words each. This allows ancillary data to be written to one side of the FIFO and from the other. Thus, in each half of the FIFO, the GS9091B will write the contents of the packets up to a maximum of 1024 8-bit words.

As described in [Section 3.9.2.1](#), up to five specific types of ancillary data to be extracted can be programmed in the ANC_TYPE registers. If the ANC_TYPE registers are all set to zero, the device will extract all types of ancillary data.

The entire packet, including the ancillary data flag (ADF), data identification (DID), secondary data identification (SDID), data count (DC), and checksum word will be written into the memory. The device will detect ancillary data packet DID's placed anywhere in the video data stream, including the active picture area.

Additionally, the lines from which the packets are to be extracted from can be programmed into the ANC_LINE_A[10:0] and ANC_LINE_B[10:0] registers, allowing ancillary data from a maximum of two lines per frame to be extracted. If only one line number register is programmed (with the other set to zero), ancillary data packets will be extracted from one line per frame only. When both registers are set to zero, the device will extract packets from all lines.

The extracted ancillary data is read through the host interface starting at address 02Ch up to 42Bh inclusive (1024 words). This must be done while there is a valid video signal present at the serial input and the device is locked (LOCKED = HIGH).

3.10.3.1 Ancillary Data Extraction and Reading

To start ancillary data extraction, the ANC_PKT_EXT bit of the IOPROC_DISABLE register must be set HIGH (see [Table 3-14](#) in [Section 3.9.8](#)). Packet extraction will begin in the following frame after this bit has been set HIGH.

NOTE: Ancillary data extraction will not begin until 2200 PCLKs (82us) after the device has entered into ancillary data extraction mode (FIFO_MODE[1:0] = 10b), regardless of the setting of the ANC_PKT_EXT bit.

When the FIFO is configured for ancillary data extraction mode, setting the IOPROC_EN pin LOW will disable packet extraction. If IOPROC_EN is LOW, the setting of the ANC_PKT_EXT host interface bit will be ignored.

Clearing the ANC_PKT_EXT bit will not automatically disable ancillary data extraction. To disable ancillary data extraction, switch the FIFO into bypass mode by setting FIFO_MODE[1:0] = 11b. 2200 PCLK cycles after the device re-enters ancillary data extraction mode, data extraction will commence immediately if ANC_PKT_EXT is still HIGH.

The ANC output flag available on the I/O output pin (see [Section 3.12](#)) can be used to determine the length of the ancillary data extracted and when to begin reading the extracted data from memory. Recall that ANC is HIGH whenever ancillary data has been detected.

In addition, the data count (DC) word, which is located three words after the ancillary data flag (ADF) in the memory, can be read to determine how many valid user data words (UDW) are present in the extracted packet (see SMPTE 291M for more details). The DC value can then be used to preset how many address reads must be performed to obtain only the user data words.

Ancillary data will be written into the first half of the FIFO until it is full or until the ANC_DATA_SWITCH bit is toggled (i.e. a HIGH-to-LOW or LOW-to-HIGH transition). If the ANC_DATA_SWITCH bit is not toggled, extracted data will not be written into memory after the first half of the FIFO is full (see block A in [Figure 3-13](#)).

When the ANC_DATA_SWITCH bit is toggled, new extracted data will be written to the second half starting at address zero (see block B in [Figure 3-13](#)). The data in the first half of the FIFO may still be read.

Once the data in the first half of the FIFO has been read, the ANC_DATA_SWITCH may be toggled again to enable the second half of the FIFO to be read. The first half of the FIFO will be cleared, and the device will continue to write ancillary data to the second half of the FIFO (see block C in [Figure 3-13](#)).

If the ANC_DATA_SWITCH bit is toggled again, new extracted data will be written to the first half starting at address zero (see block D in [Figure 3-13](#)). The data in the second half of the FIFO may still be read.

Toggling ANC_DATA_SWITCH again will clear the second half of the FIFO and restore the read and write pointers to the situation shown in block A. The switching process (shown in blocks A to D in [Figure 3-13](#)) will continue with each toggle of the ANC_DATA_SWITCH bit.

NOTE: At least 1100 PCLK cycles (41us) must pass between toggles of the ANC_DATA_SWITCH bit. Also, the ANC_DATA_SWITCH bit must be toggled at a point in the video where no extraction is occurring (i.e. the ANC signal is LOW).

By default, the ancillary data is not removed from the video stream. If desired, the ancillary data may be deleted from the video stream after extraction by setting the ANC_DATA_DELETE bit of the host interface HIGH. In this case, all existing ancillary data will be removed and replaced with blanking values. If any of the ANC_TYPE registers are programmed with a DID and/or a DID and SDID, only the ancillary data packets with the matching ID's will be deleted from the video stream.

NOTE: After the ancillary data determined by the ANC_TYPE registers has been deleted, other existing ancillary data may not be contiguous. The device will not concatenate the remaining ancillary data.

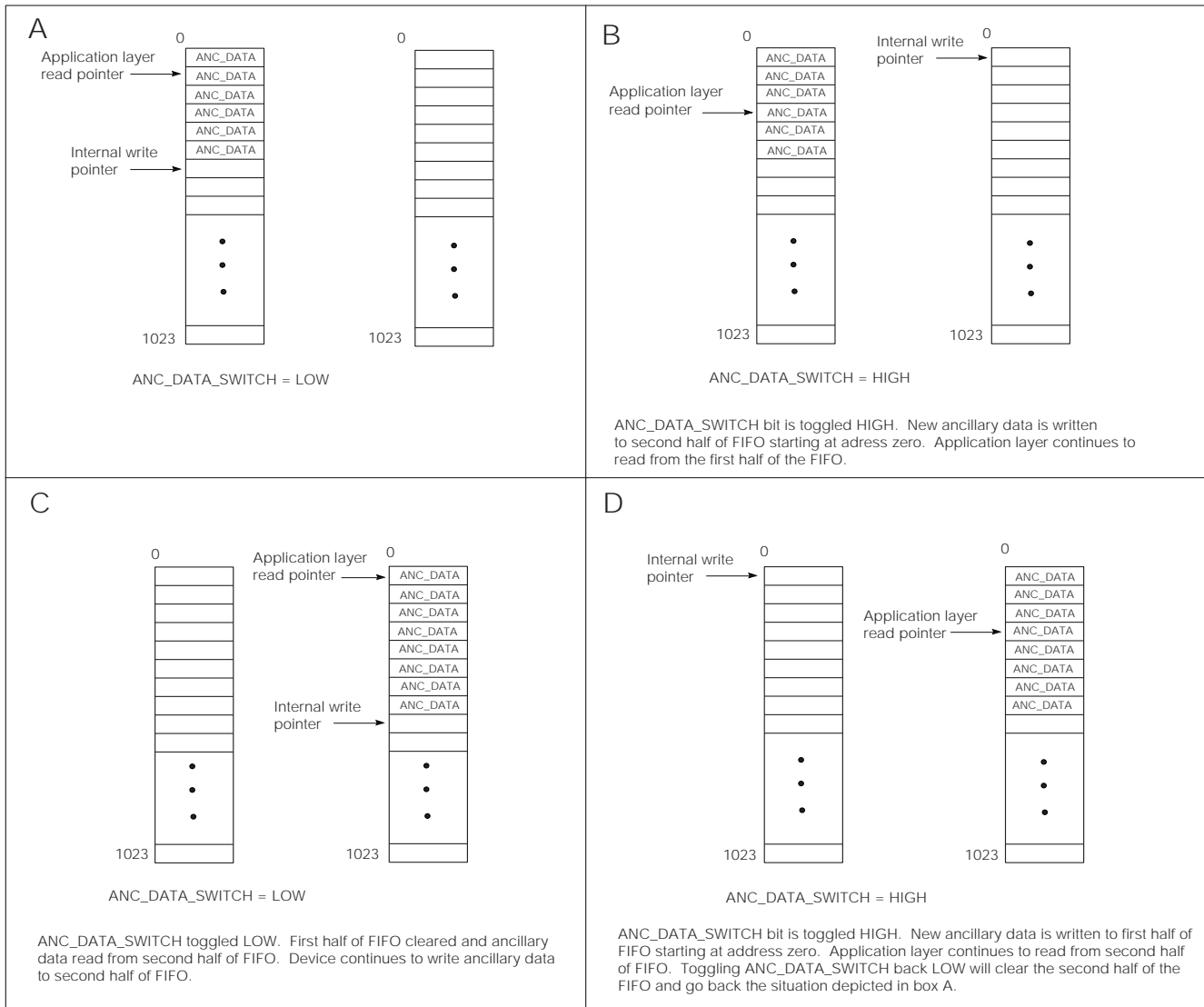

NOTE: At least 1100 PCLK cycles must pass between toggles of the ANC_DATA_SWITCH bit. The bit must be toggled at a point where no extraction is occurring (i.e. the ANC signal is LOW).

Figure 3-13: Ancillary Data Extraction and Reading

3.10.4 Bypass Mode

The internal FIFO is in bypass mode when the FIFO_EN or IOPROC_EN pin is set LOW, or the FIFO_MODE[1:0] bits in the IOPROC_DISABLE register are configured to 11b. By default, the FIFO_MODE[1:0] bits are set to 11b by the device whenever both the SMPTE_BYPASS and DVB_ASI pins are LOW; however, the FIFO_MODE[1:0] bits may be programmed as required.

In bypass mode, the FIFO is not inserted into the video path and data is presented to the output of the device synchronously with the PCLK output. The FIFO will be disabled and placed in static mode to save power.

3.11 Parallel Data Outputs

The parallel data outputs are clocked out of the device on the rising edge of PCLK as shown in Figure 3-14.

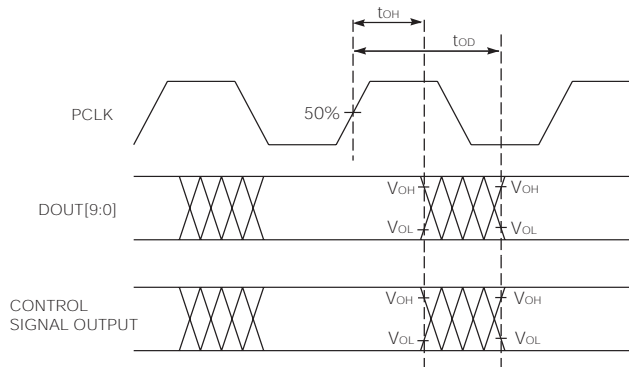

Figure 3-14: PCLK to Data & Control Signal Output Timing

The output data format is defined by the settings of the external $\overline{\text{SMPTE_BYPASS}}$ and $\overline{\text{DVB_ASI}}$ pins (see Table 3-16). In Manual mode, these pins are set as inputs to the device. In Auto mode, the GS9091B sets these pins as output status signals.

Table 3-16: Parallel Data Output Format

Output Data Format	DOUT[9:0]	Pin Settings	
		$\overline{\text{SMPTE_BYPASS}}$	$\overline{\text{DVB_ASI}}$
10-bit Data	DATA	LOW	LOW
10-bit Multiplexed SD	Luma / Chroma	HIGH	LOW
10-bit DVB-ASI	DVB-ASI data	LOW	HIGH

3.11.1 Parallel Data Bus Output Buffers

The parallel data outputs of the GS9091B are driven by high-impedance buffers that support both LVTTTL and LVCMOS levels. These buffers use either +1.8V or +3.3V, supplied at the IO_VDD and IO_GND pins. When interfacing with +5V logic levels, the IO_VDD pins should be supplied with +3.3V. For a low power connection, the IO_VDD pins may be connected to +1.8V.

All output buffers, including the PCLK output, will be in a high-impedance state when the $\overline{\text{RESET}}$ signal is asserted LOW.

3.11.2 Parallel Output in SMPTE Mode

When the device is operating in SMPTE mode (see [Section 3.6](#)), SMPTE data is output on the DOUT[9:0] pins.

3.11.3 Parallel Output in DVB-ASI Mode

When operating in DVB-ASI mode (see [Section 3.7](#)), the decoded 8-bit data words will be presented on DOUT[7:0]. DOUT7 = HOUT is the most significant bit of the decoded transport stream data and DOUT0 = AOUT is the least significant bit. DOUT9 will be configured as the DVB-ASI status signal WORDERR and DOUT8 as SYNCOUT. See [Section 3.7.2](#) for a description of these DVB-ASI specific output signals.

3.11.4 Parallel Output in Data-Through Mode

When operating in Data-Through mode (see [Section 3.8](#)), the GS9091B presents data to the output data bus without performing any decoding, descrambling, or word-alignment.

3.12 Programmable Multi-Function Outputs

The GS9091B has a 4-pin multi-function output port, STAT[3:0]. Each pin can be programmed to output one of the following signals: H, V, F, $\overline{\text{FIFO_LD}}$, ANC, EDH_DETECT, FIFO_FULL, and FIFO_EMPTY.

Table 3-17: Output Signals Available on Multi-Function Output Ports

Output Status Signal	Reference
H	Section 3.6.4
V	Section 3.6.4
F	Section 3.6.4
$\overline{\text{FIFO_LD}}$	Section 3.9.1
ANC	Section 3.9.2
EDH_DETECT	Section 3.9.3
FIFO_FULL	Section 3.10.2.1
FIFO_EMPTY	Section 3.10.2.1

Each of the STAT[3:0] pins can be configured individually using the STAT0_CONFIG[2:0], STAT1_CONFIG[2:0], STAT2_CONFIG[2:0], and STAT3_CONFIG[2:0] registers. [Table 3-18](#) shows the setting of the IO_CONFIG registers for each of the available output signals.

Table 3-18: IO_CONFIG Settings

Function	I/O	IO_CONFIG Setting
H	Output	000b
V	Output	001b
F	Output	010b
FIFO_LD	Output	011b
ANC	Output	100b
EDH_DETECT	Output	101b
FIFO_FULL	Output	110b
FIFO_EMPTY	Output	111b

The default setting for each IO_CONFIG register depends on the configuration of the device and the internal FIFO mode selected. This is shown in [Table 3-19](#).

If the programmed signal is not relevant to the current mode of operation, the output will be set to a high-impedance state.

Table 3-19: IO_CONFIG Default Configuration

Device Configuration	IO_CONFIG Register	I/O	Function	Default IO_CONFIG Setting
SMPTE Functionality SMPTE_BYPASS = HIGH DVB_ASI = LOW FIFO: Video Mode or Ancillary Data Extraction Mode	STAT0_CONFIG	Output	H	000b
	STAT1_CONFIG	Output	V	001b
	STAT2_CONFIG	Output	F	010b
	STAT3_CONFIG	Output	FIFO_LD	011b
DVB-ASI DVB_ASI = HIGH FIFO: DVB-ASI Mode	STAT0_CONFIG	Output	FIFO_FULL	110b
	STAT1_CONFIG	Output	FIFO_EMPTY	111b
	STAT2_CONFIG	Output	High Z	000b
	STAT3_CONFIG	Output	High Z	000b
Data-Through SMPTE_BYPASS = LOW DVB_ASI = LOW	STAT0_CONFIG	Output	High Z	000b
	STAT1_CONFIG	Output	High Z	000b
	STAT2_CONFIG	Output	High Z	000b
	STAT3_CONFIG	Output	High Z	000b

3.13 GS9091B Low-latency Mode

When the IOPROC_EN pin is set LOW, the GS9091B will be set into low-latency mode. The parallel data will be output with the minimum PCLK latency possible. The FIFO and all processing blocks except the descrambling and word alignment blocks will be bypassed when SMPTE_BYPASS is HIGH.

Low-latency mode will also be selected when SMPTE_BYPASS is set LOW, regardless of the setting of the IOPROC_EN signal (see Table 3-20).

In DVB-ASI mode, the device latency is less than in SMPTE mode.

Table 3-20: Pin Settings in Low-latency Mode

IOPROC_EN Setting	SMPTE_BYPASS Setting	Latency (PCLK Cycles)
LOW	LOW	9
HIGH	LOW	10
LOW	HIGH	10
HIGH	HIGH	25

NOTE: Latency applies to parallel processing core only.

When the GS9091B is configured for low-latency mode, the H,V, and F output timing will be based on the incoming TRS codes as shown in Figure 3-14. Active line-based timing is not available and the setting of the H_CONFIG host interface bit will be ignored.

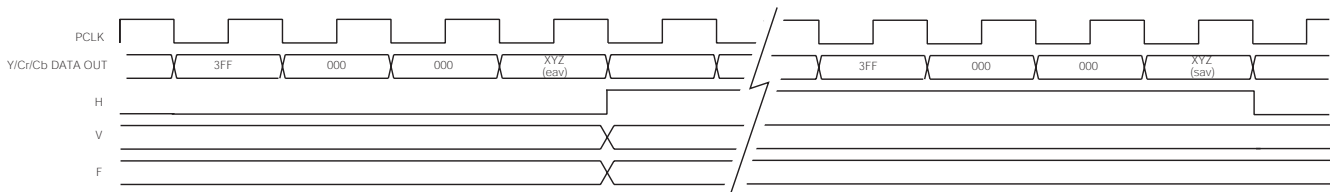

Figure 3-15: H,V,F Timing In Low-latency Mode

3.14 GSPI Host Interface

The GSPI, or Genum Serial Peripheral Interface, is a 4-wire interface provided to allow access to the host interface of the GS9091B and/or to provide additional status information through configuration registers in the device.

The GSPI comprises a serial data input signal SDIN, serial data output signal SDOUT, an active low chip select \overline{CS} , and a burst clock SCLK. The burst clock must have a duty cycle between 40% and 60%.

Because these pins are shared with the JTAG interface port, an additional control signal pin JTAG_EN is provided. When JTAG_EN is LOW, the GSPI interface is enabled.

When operating in GSPI mode, the SCLK, SDIN, and \overline{CS} signals are provided by the application interface. The SDOUT pin is a non-clocked loop-through of SDIN and may be connected to the SDIN of another device, allowing multiple devices to be connected to the GSPI chain. The interface is illustrated in [Figure 3-16](#).

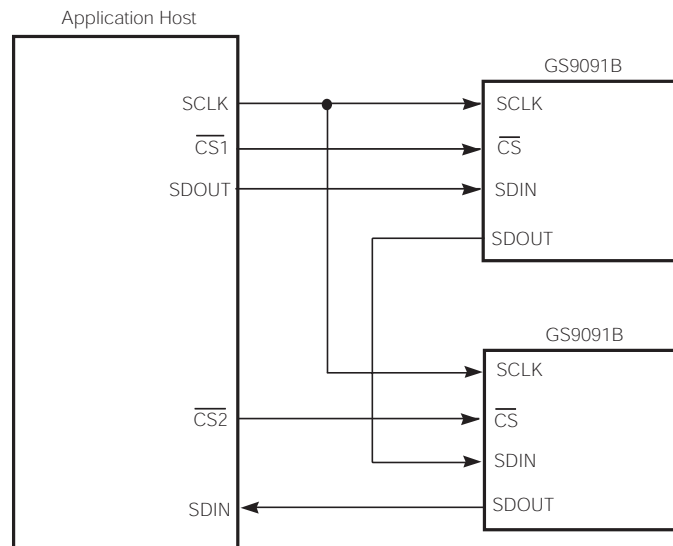

Figure 3-16: GSPI Application Interface Connection

All read or write access to the GS9091B is initiated and terminated by the host processor. Each access always begins with a 16-bit command word on SDIN indicating the address of the register of interest. This is followed by a 16-bit data word on SDIN in write mode, or a 16-bit data word on SDOUT in read mode.

3.14.1 Command Word Description

The command word consists of a 16-bit word transmitted MSB first and contains a read/write bit, an Auto-Increment bit and a 12-bit address. [Figure 3-17](#) shows the command word format and bit configurations.

Command words are clocked into the GS9091B on the rising edge of the serial clock SCLK, which operates in a burst fashion.

When the Auto-Increment bit is set LOW, each command word must be followed by only one data word to ensure proper operation. If the Auto-Increment bit is set HIGH, the following data word will be written into the address specified in the command word, and subsequent data words will be written into incremental addresses from the previous data word. This facilitates multiple address writes without sending a command word for each data word.

Auto-Increment may be used for both read and write access.

3.14.2 Data Read and Write Timing

Read and write mode timing for the GSPI interface is shown in [Figure 3-19](#) and [Figure 3-20](#) respectively. The timing parameters are defined in [Table 3-21](#).

When several devices are connected to the GSPI chain, only one \overline{CS} must be asserted during a read sequence.

During the write sequence, all command and following data words input at the SDIN pin are output at the SDOOUT pin as is. Where several devices are connected to the GSPI chain, data can be written simultaneously to all the devices that have \overline{CS} set LOW.

Table 3-21: GSPI Timing Parameters

Parameter	Definition	Specification
t_0	The minimum duration of time chip select, \overline{CS} , must be LOW before the first SCLK rising edge.	1.5 ns
t_1	The minimum SCLK period.	12.5 ns
t_2	Duty cycle tolerated by SCLK.	40% to 60%
t_3	Minimum input setup time.	1.5 ns
t_4	Write Cycle: the minimum duration of time between the last SCLK command (or data word if the Auto-Increment bit is HIGH) and the first SCLK of the data word.	37.1 ns
t_5	Read Cycle: the minimum duration of time between the last SCLK command (or data word if the Auto-Increment bit is HIGH) and the first SCLK of the data word.	148.4 ns
t_5	Read Cycle - FIFO in ANC Extraction Mode: the minimum duration of time between the last SCLK command (or data word if the Auto-Increment bit is HIGH) and the first SCLK of the data word.	222.6 ns
t_6	Minimum output hold time.	1.5 ns
t_7	The minimum duration of time between the last SCLK of the GSPI transaction and when \overline{CS} can be set HIGH.	37.1 ns
t_8	Minimum input hold time.	1.5 ns

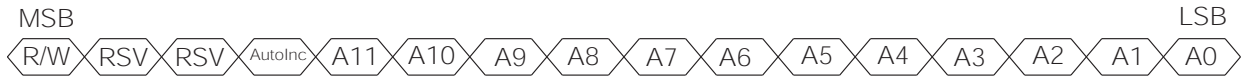

RSV = Reserved. Must be set to zero. R/W: Read command when R/W = 1
Write command when R/W = 0

Figure 3-17: Command Word Format

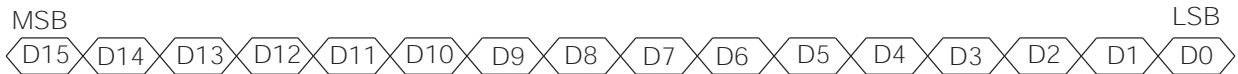

Figure 3-18: Data Word Format

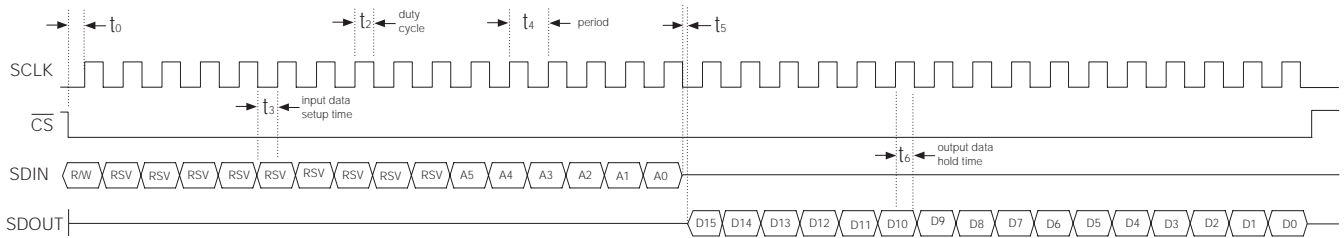

Figure 3-19: GSPI Read Mode Timing

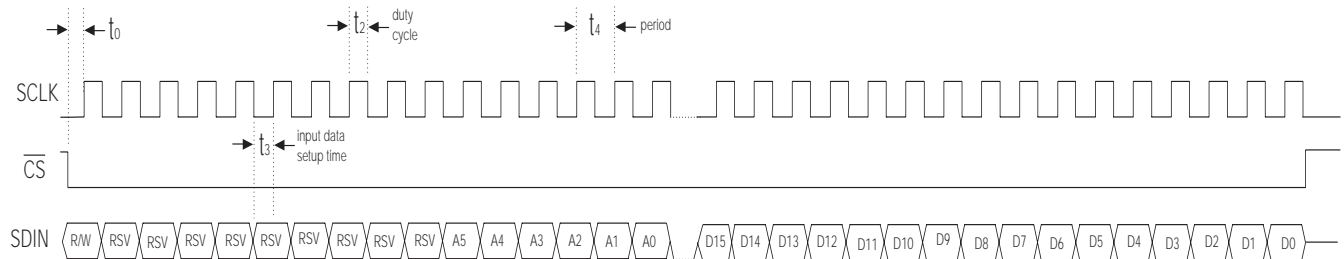

Figure 3-20: GSPI Write Mode Timing

3.14.3 Configuration and Status Registers

Table 3-22 summarizes the GS9091B's internal status and configuration registers.

All of these registers are available to the host via the GSPI and are all individually addressable.

Where status registers contain less than the full 16 bits of information, two or more registers may be combined at a single logical address.

Table 3-22: GS9091B Internal Registers

Address	Register Name	Reference
00h	IOPROC_DISABLE	Section 3.9.8
01h	ERROR_STATUS	Section 3.9.7
02h	EDH_FLAG_IN	Section 3.9.4
03h	EDH_FLAG_OUT	Section 3.9.4
04h	DATA_FORMAT	Section 3.9.6.1
05h	IO_CONFIG	Section 3.12
06h	FIFO_EMPTY_OFFSET	Section 3.10.2.1
07h	FIFO_FULL_OFFSET	Section 3.10.2.1
08h - 0Eh	ANC_TYPE	Section 3.9.2
11h - 14h	RASTER_STRUCTURE	Section 3.9.6
15h - 24h	EDH_CALC_RANGES	Section 3.9.7.2
25h	ERROR_MASK	Section 3.9.7
28h	FIFO_LD_POSITION	Section 3.9.1.1
02Ch - 42Bh	INTERNAL FIFO	Section 3.10.3 Ancillary Data Extraction Mode

3.15 JTAG operation

When the JTAG_EN pin is set HIGH, the host interface port (as described in Section 3.14) will be configured for JTAG test operation. In this mode, pins J4, K5, J5, and K6 become TMS, TCK, TDO, and TDI respectively. In addition, the RESET pin will operate as the test reset pin, as well as resetting the internal registers.

Boundary scan testing using the JTAG interface will be possible in this mode.

There are two methods in which JTAG can be used on the GS9091B:

1. As a stand-alone JTAG interface to be used at in-circuit ATE (Automatic Test Equipment) during PCB assembly; or
2. Under control of the host for applications such as system power self tests.

When the JTAG tests are applied by ATE, care must be taken to disable any other devices driving the digital I/O pins. If the tests are to be applied only at ATE, this can be accomplished with tri-state buffers used in conjunction with the JTAG_EN input signal. This is shown in Figure 3-21.

Alternatively, if the test capabilities are to be used in the system, the host may still control the JTAG_EN input signal, but some means for tri-stating the host must exist in order to use the interface at ATE. This is represented in Figure 3-22.

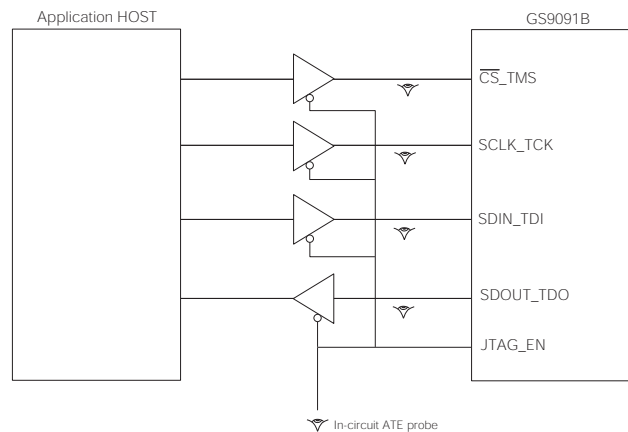

Figure 3-21: In-Circuit JTAG

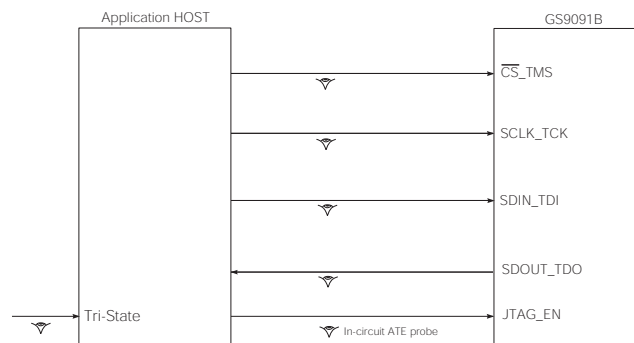

Figure 3-22: System JTAG

3.16 Device Power Up

The GS9091B has a recommended power supply sequence. To ensure correct power up, power the CORE_VDD pins before the IO_VDD pins. In order to initialize all internal operating conditions to their default state the application layer must hold the RESET pin LOW for a minimum of $t_{\text{reset}} = 1\text{ms}$. (See [Figure 3-23](#))

Device pins can be driven prior to power up without causing damage.

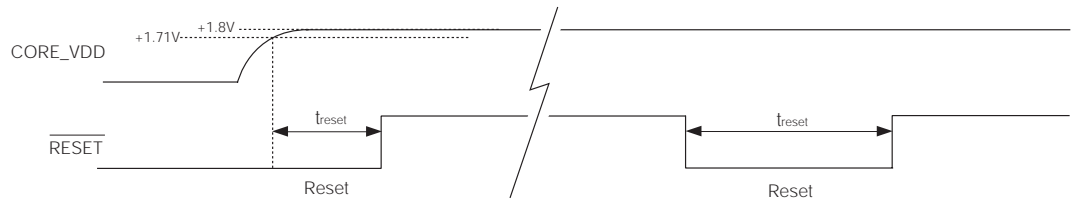

Figure 3-23: Reset pulse

4. References & Relevant Standards

SMPTE 125M	Component video signal 4:2:2 – bit parallel interface
SMPTE 259M	10-Bit 4:2:2 Component and 4f _{SC} Composite Digital Signals - Serial Digital Interface
SMPTE 291M	Ancillary Data Packet and Space Formatting
SMPTE 293M	720 x 483 active line at 59.94 Hz progressive scan production – digital representation
SMPTE 305.2M	Serial Data Transport Interface
SMPTE 352M	Video Payload Identification for Digital Television Interfaces
SMPTE RP165	Error Detection Checkwords and Status Flags for Use in Bit-Serial Digital Interfaces for Television
SMPTE RP168	Definition of Vertical Interval Switching Point for Synchronous Video Switching

5. Application Information

5.1 Typical Application Circuit

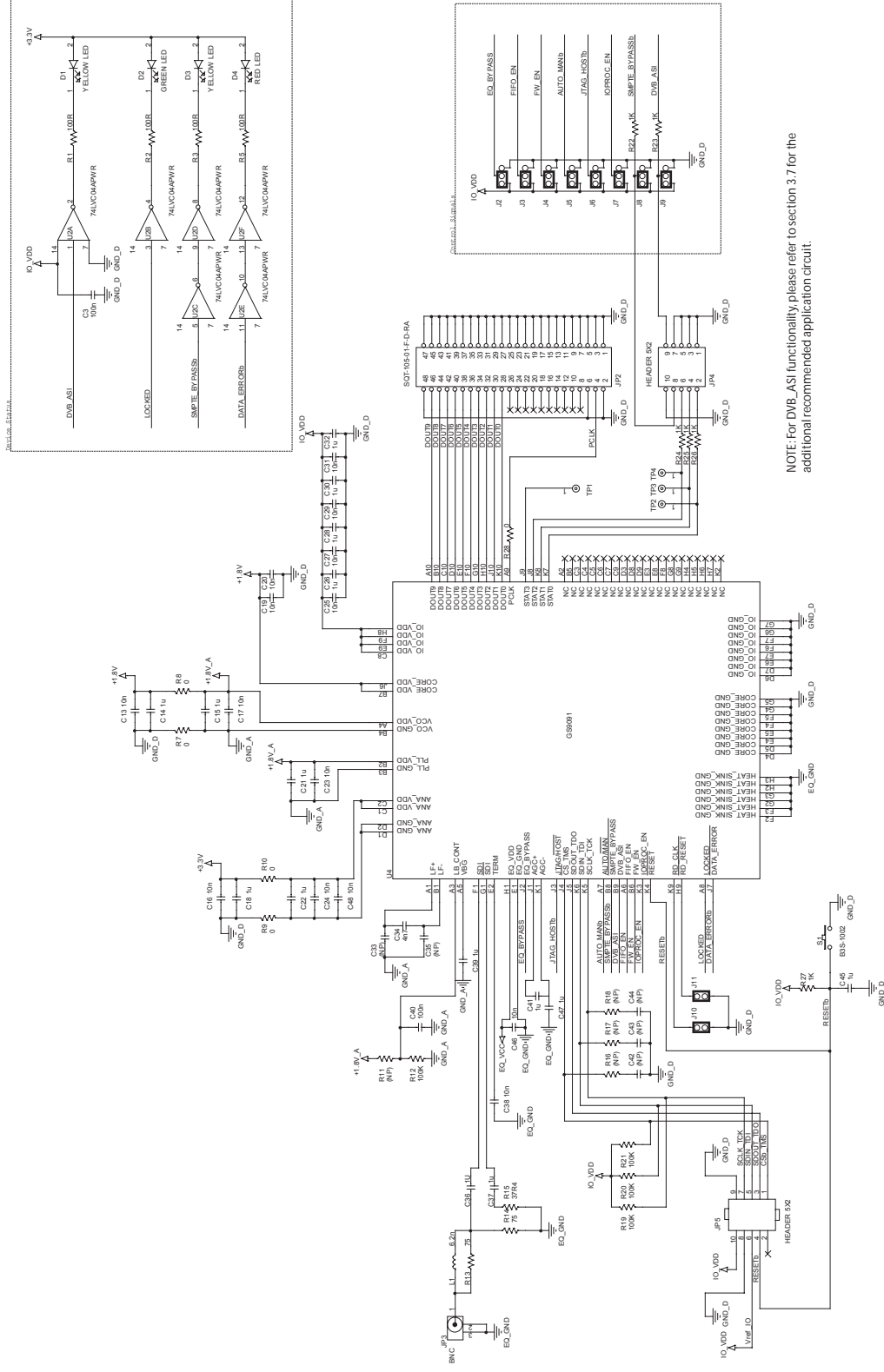

NOTE: For DVB_ASI functionality, please refer to section 3.7 for the additional recommended application circuit.

6. Package & Ordering Information

6.1 Package Dimensions

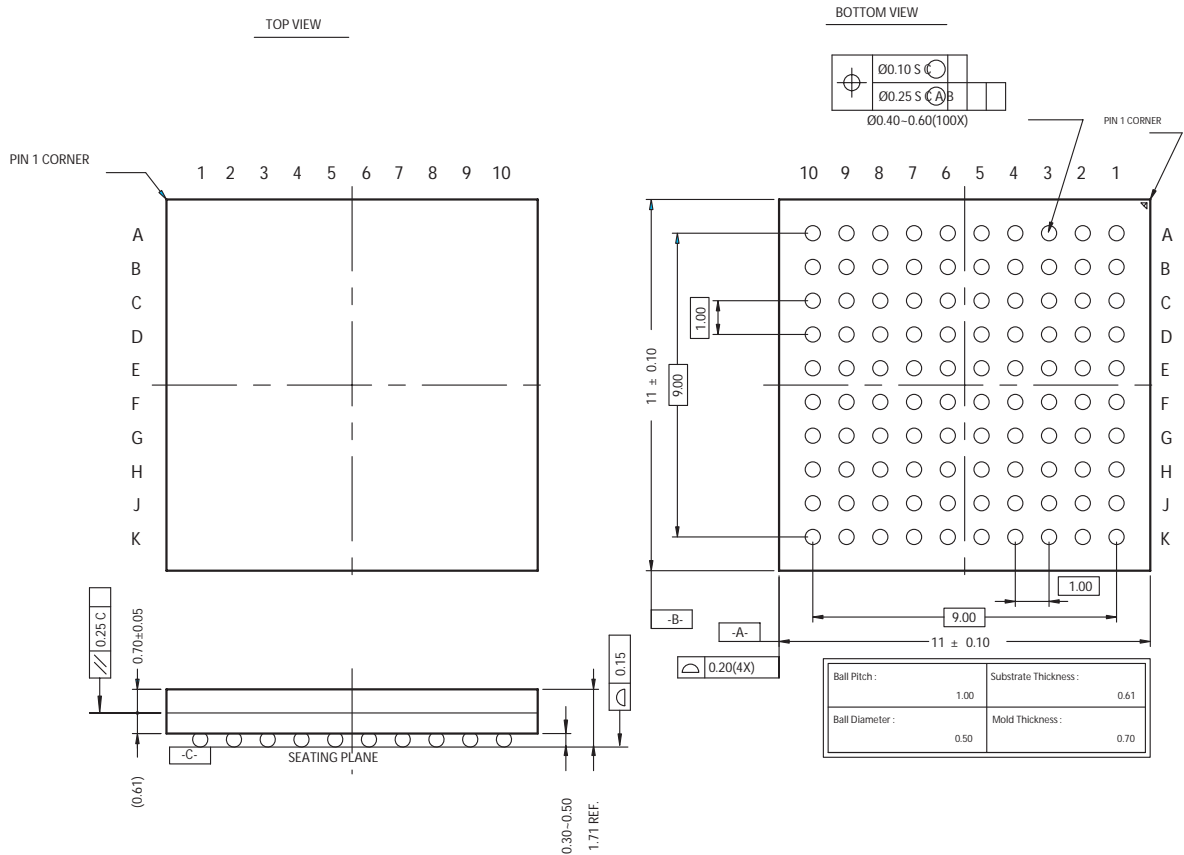

* THE BALL DIAMETER, BALL PITCH, STAND-OFF & PACKAGE THICKNESS ARE DIFFERENT FROM JEDEC SPEC M0192 (LOW PROFILE BGA FAMILY)

6.2 Packaging Data

Parameter	Value
Package Type	11mm x 11mm 100 LBGA
Moisture Sensitivity Level	3
Junction to Case Thermal Resistance, θ_{j-c}	41.4
Junction to Air Thermal Resistance, θ_{j-a} (at zero airflow)	74.5
Psi, Ψ	55.2
Pb-free and RoHS compliant	Yes

6.3 Marking Diagram

Pin 1 ID



XXXX - Lot/Work Order ID

YYWW - Date Code

YY - 2-digit year

WW - 2-digit week number

6.4 Ordering Information

Part Number	Package	Temperature Range
GS9091BCBE3	Pb-free 100-BGA	0°C to 70°C

7. Revision History

Version	ECR	Date	Changes and/or Modifications
0	139930	November 2006	New Document.
1	144807	April 2007	Converting to Data Sheet. Modified Electrical Characteristics .

CAUTION

ELECTROSTATIC SENSITIVE DEVICES
DO NOT OPEN PACKAGES OR HANDLE
EXCEPT AT A STATIC-FREE WORKSTATION



DOCUMENT IDENTIFICATION

DATA SHEET

The product is in production. Gennum reserves the right to make changes to the product at any time without notice to improve reliability, function or design, in order to provide the best product possible.

GENNUM CORPORATION

Mailing Address: P.O. Box 489, Stn. A, Burlington, Ontario, Canada L7R 3Y3
Shipping Address: 970 Fraser Drive, Burlington, Ontario, Canada L7L 5P5
Tel. +1 (905) 632-2996 Fax. +1 (905) 632-5946

GENNUM JAPAN CORPORATION

Shinjuku Green Tower Building 27F, 6-14-1, Nishi Shinjuku, Shinjuku-ku, Tokyo, 160-0023 Japan
Tel. +81 (03) 3349-5501, Fax. +81 (03) 3349-5505

GENNUM UK LIMITED

25 Long Garden Walk, Farnham, Surrey, England GU9 7HX
Tel. +44 (0)1252 747 000 Fax +44 (0)1252 726 523

Gennum Corporation assumes no liability for any errors or omissions in this document, or for the use of the circuits or devices described herein. The sale of the circuit or device described herein does not imply any patent license, and Gennum makes no representation that the circuit or device is free from patent infringement.

GENNUM and the G logo are registered trademarks of Gennum Corporation.

© Copyright 2006 Gennum Corporation. All rights reserved. Printed in Canada.

www.gennum.com