

PANEL  
SEALED  
PUSH  
BUTTON

# SERIES 76-97

## FEATURES

- Wide temperature range: from -40°C to + 105°C
- Panel sealed product – Protection against immersion
- Maintained mode

## NON-STANDARD OPTIONS

- PCB terminals
- Gold contacts
- 2 poles available
- Colour variants
- Surface or sublimation legend printing

The 76-97 series of push button switches is robust.

The switch body and button are made from hard-wearing plastic and produced in front mounting style.

The 76-97 series can be used in momentary or maintained mode. In addition the buttons carry a brightly coloured switch indicator which gives an 'at a glance' recognition of the mode currently in use.

Buttons and status rings can be supplied in a variety of colours or to customers own specifications.

The 76-97 utilises ITW Switches' proven Series 16 snap action microswitch.

## TECHNICAL

### MECHANICAL

Travel	3.5 mm
Life (nom)	2 x 10 <sup>6</sup> (Momentary) 1 x 10 <sup>5</sup> (Latched)
Operating force	12N (nominal)
Contact bounce	5ms
Panel thickness (max)	6 mm

### ELECTRICAL

Dielectric strength	1000V RMS
Insulation resistance	1GΩ
Contact resistance (initial)	25mΩ
Current rating (max)	10A resistive 250V a.c.
Life	100,000 cycles @ 20°C

### ENVIRONMENTAL AND PHYSICAL

Ingress protection	IP67
Shock	50g
Operating temperature range	-40°C to + 105°C
Body material	PBT
Actuator material	PBT
Contact material	Fine silver
Terminal material	5µm bright acid tin plate, nickel flash undercoat.

## APPLICATIONS

- Military environments ■ Robust industrial
- Mining industry ■ Petrochemical
- Process control ■ Material handling

SERIES 76-97

**ITW Switches**  
**ITW Switchpanels**

## ORDERING

### BUTTON STYLE

Raised – 1

### ACTION

Momentary – 1

Maintained – 2

### TERMINATION & No. OF POLES

Solder/faston	1 pole	/439088
Solder	1 pole	/4044
Solder	2 poles	/804

### BUTTON COLOUR/IDENTITY RING

#### COLOUR

Black/red	B
Red/yellow	R
Green/yellow	G
White/yellow	W
Yellow/red	Y
Blue/red	N
Light grey/red	GY

### PANEL MOUNTING AND CONSTRUCTION INFORMATION

The 76-97 mounts easily into panels not exceeding 6mm thickness. Front panel sealing to IP67 is achieved by use of the sealing washer which is fitted to the switch before it is inserted into the panel hole cut out. It is held into the panel by means of a lock nut, tightened down to a torque of between 1,5Nm to 2,85Nm to achieve the correct sealing pressure. It is mounted into a standard 22,5mm diameter and a double 'D' flat is provided to prevent rotation if required.

### MULTI-POLE INFORMATION

The Series 76-97 has a non-standard option of 2 poles. The 2 pole switch is provided separate to the switch body and must be fitted, via a spring clip, after the switch body has been mounted in the panel.

### CIRCUIT FORM

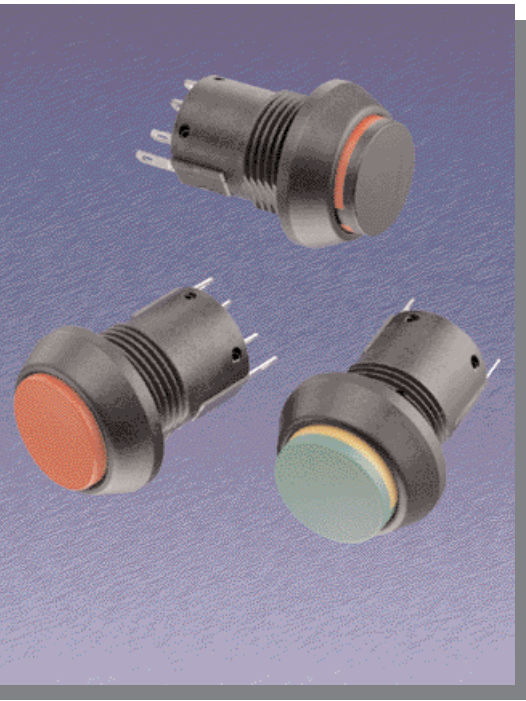

## SERIES 76-97

### PRODUCT DIMENSIONS

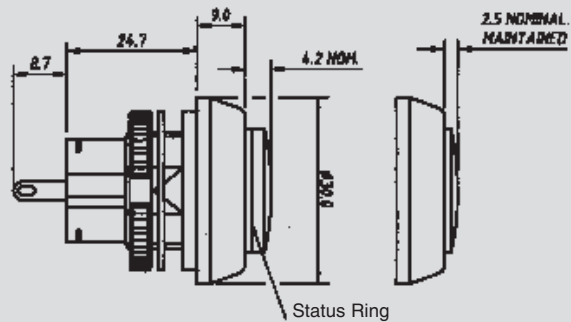

### INGRESS PROTECTION

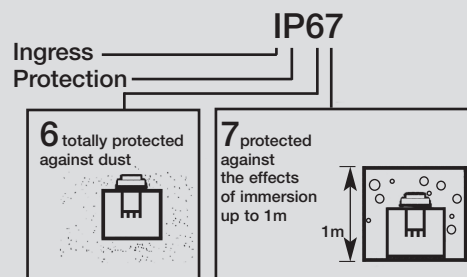

### FURTHER INFORMATION

#### ITW Switches

A Division of ITW Limited  
 Norway Road, Portsmouth,  
 England PO3 5HT  
 Tel: 00 44 (0) 2392 656200  
 Fax: 00 44 (0) 2392 666352

e-mail:  
[info@itwswitches.co.uk](mailto:info@itwswitches.co.uk)

website:  
[www.itwswitches.co.uk](http://www.itwswitches.co.uk)

Due to our policy of continuous product development, ITW Switches retain the right to change the specification at any time without prior notice. Designed & printed in the UK.

**ITW Switches**  
**ITW Switchpanels**