

910 087
090
107

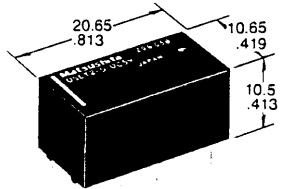

BABT APPROVED RELAYS

DS-BT RELAYS



mm inch

BABT CR No.: 0104
UL File No.: E43149
CSA File No.: LR26550

- BABT (Certificate of Recognition)
- 4,000 V breakdown voltage
- Reinforced insulation between coil and contacts
- Surge voltage withstand: 1500 V FCC Parts 68

SPECIFICATIONS

Contact		2 Form C	2 Form D
Arrangement		2 Form C	2 Form D
Initial contact resistance, max. (By voltage drop 6 V DC 1 A)		50 mΩ	
Contact material		Gold-clad silver	
Rating (resistive load)	Nominal switching capacity	2 A 30 V DC	1 A 30 V DC
	Max. switching power	60 W, 125 VA	30 W, 62.5 VA
	Max. switching voltage	220 V DC, 250 V AC	
	Max. switching current	2 A	1 A
	Min. switching capability	10 μA 10 mV DC	
UL/CSA rating		2 A 30 V DC 0.6 A 110 V DC 0.6 A 125 V AC	1 A 30 V DC
Electrical life (min. ope.)	Mechanical (at 180 cpm)	2×10 ⁷	10 ⁶
	Electrical (at 20 cpm)	2×10 ⁵	
Coil		2 Form C	2 Form D
Arrangement		2 Form C	2 Form D
Nominal operating power		360 mW	540 mW

Characteristics		2 Form C	2 Form D
Arrangement		2 Form C	2 Form D
Max. operating speed		60 cpm of rated load	
Operate time (at nominal voltage)		Approx. 3 msec.	
Release time (at nominal voltage)		Approx. 2 msec.	
Initial breakdown voltage	Between open contacts	750 Vrms for 1 min.	500 Vrms for 1 min.
	Between contacts and coil	4,000 Vrms for 1 min.	
Initial insulation resistance		Min. 100 MΩ (at 500 V DC)	
Fcc surge voltage between open contacts		1,500 V	
Temperature rise, max. (at nominal voltage)		65 deg.	
Ambient temperature		-40°C to +70°C -40°F to +158°F	-40°C to +60°C -40°F to +140°F
Shock resistance	Functional	Min. 30 G	
	Destruction	Min. 100 G	
Vibration resistance	Functional	20 G, 10 to 55 Hz at double amplitude of 3.3 mm	
	Destruction	30 G, 10 to 55 Hz at double amplitude of 5 mm	
Unit weight		4.9 g 0.17 oz	

TYPICAL APPLICATION

Modem
Facsimile
Telecommunication equipment

ORDERING INFORMATION

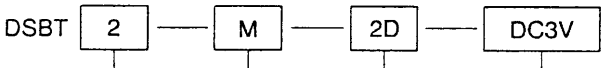

Contact arrangement	Sensitivity	MBB function	Coil voltage
2: 2 Form C or 2 Form D	S: 360 mW (2 Form C only) M: 540 mW (2 Form D only)	Nil: BBM (Form C) 2D: 2MBB (2 Form D)	DC 1.5, 3, 5, 6, 9, 12, 24 V

Note: Standard packing Tube: 25 pcs. Case: 1,000 pcs.

TYPES AND COIL DATA (at 20°C 68°F)

1) 2 Form C type

Operating function	Part No.	Coil voltage, V DC	Pick-up voltage, V DC (max.)	Drop-out voltage, V DC (min.)	Nominal operating current, mA (±10%)	Coil resistance, Ω (±10%)	Nominal operating power, mW	Max. allowable voltage, V DC (at 50°C 122°F)
Single side stable	DSBT2-S-DC1.5V	1.5	1.125	0.15	240	6.25	360	2.25
	DSBT2-S-DC3V	3	2.25	0.3	120	25		4.5
	DSBT2-S-DC5V	5	3.75	0.5	72	69.5		7.5
	DSBT2-S-DC6V	6	4.5	0.6	60	100		9
	DSBT2-S-DC9V	9	6.75	0.9	40	225		13.5
	DSBT2-S-DC12V	12	9	1.2	30	400		18
	DSBT2-S-DC24V	24	18	2.4	15	1,600		36

2) 2 Form D type

Operating function	Part No.	Coil voltage, V DC	Pick-up voltage, V DC (max.)	Drop-out voltage, V DC (min.)	Nominal operating current, mA (±10%)	Coil resistance, Ω (±10%)	Nominal operating power, mW	Max. allowable voltage, V DC (at 50°C 122°F)
Single side stable	DSBT2-M-2D-DC1.5V	1.5	1.125	0.15	360	4.17	540	1.8
	DSBT2-M-2D-DC3V	3	2.25	0.3	180	16.7		3.6
	DSBT2-M-2D-DC5V	5	3.75	0.5	108	46.3		6
	DSBT2-M-2D-DC6V	6	4.5	0.6	90	66.7		7.2
	DSBT2-M-2D-DC9V	9	6.75	0.9	60	150		10.8
	DSBT2-M-2D-DC12V	12	9	1.2	45	266.7		14.4
	DSBT2-M-2D-DC24V	24	18	2.4	22.5	1,066.7		28.8

CONSTRUCTION

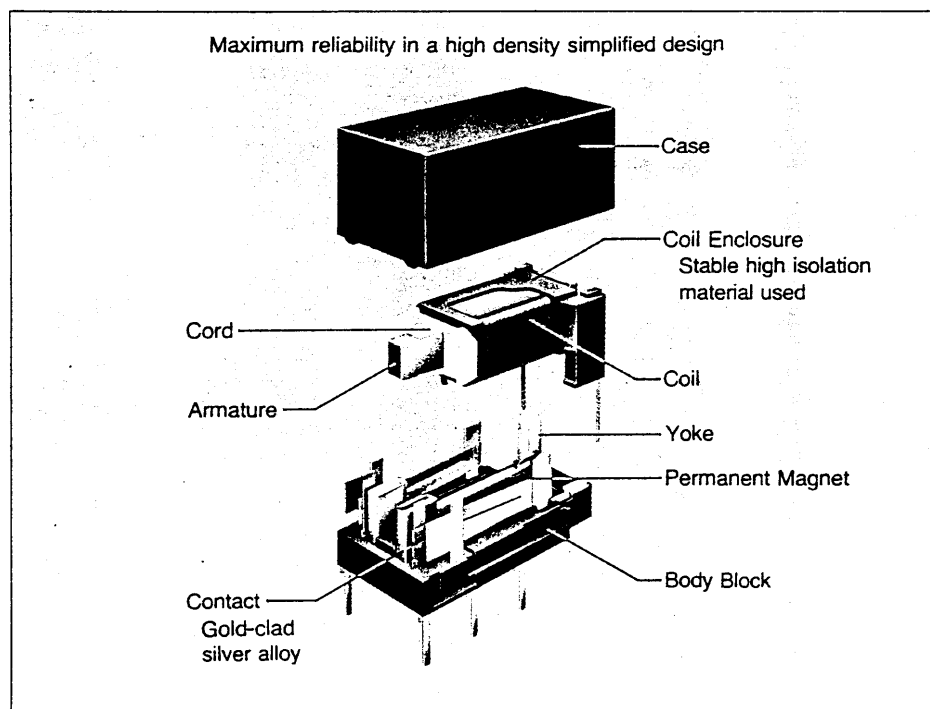

DIMENSIONS

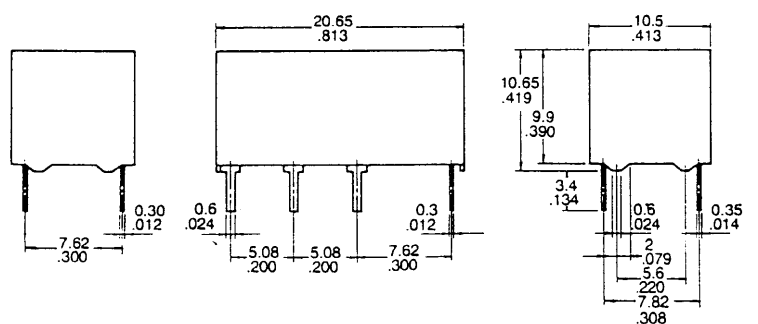

General tolerance: $\pm 0.3 \pm .012$

PC board pattern (Bottom view)

mm inch

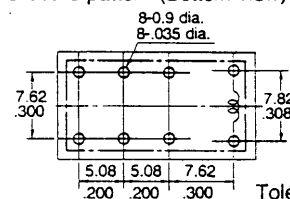

Tolerance: $\pm 0.1 \pm .004$

Schematic (Bottom view)

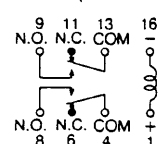

DATA

1. Mechanical life test

Tested sample: DSBT-S-DC5V, 10 pcs.
Coil applied voltage: 5 V DC
Operating frequency: 30 cpm

Change of pick-up and drop-out voltage

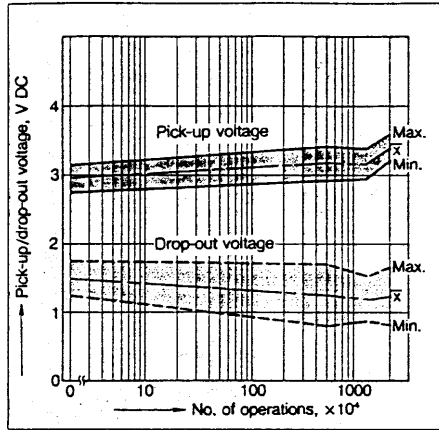

Change of contact resistance

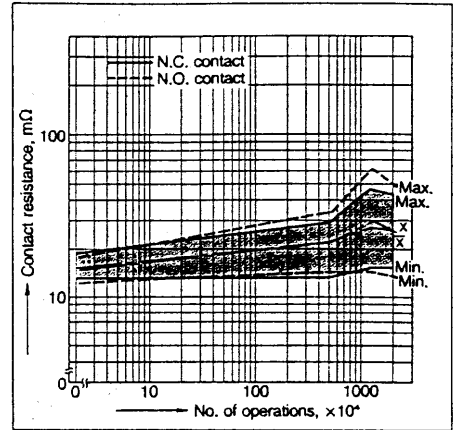

2. Electrical life test (resistive)

Tested sample: DSBT-S-DC12V, 6 pcs.
Condition: 2 A 30 V DC resistive load, 30 cpm

Circuit

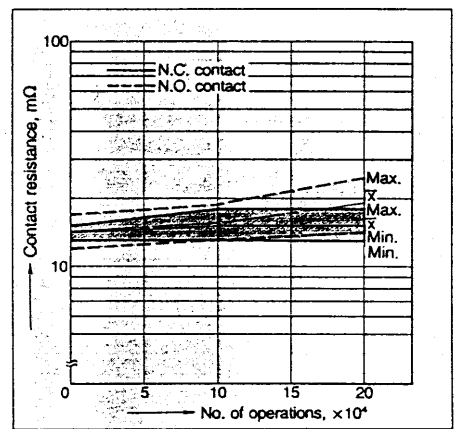
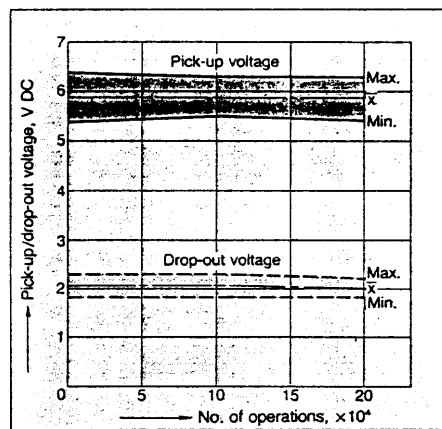
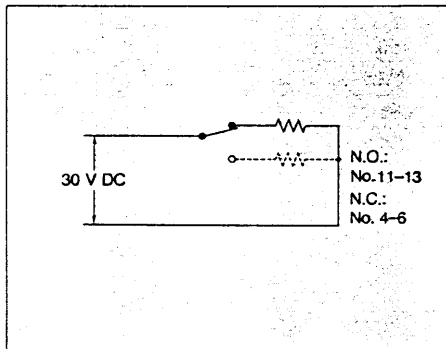

3. Coil temperature rise

Tested sample: DSBT-S-DC12V, 5 pcs.
Measured portion: Inside the coil

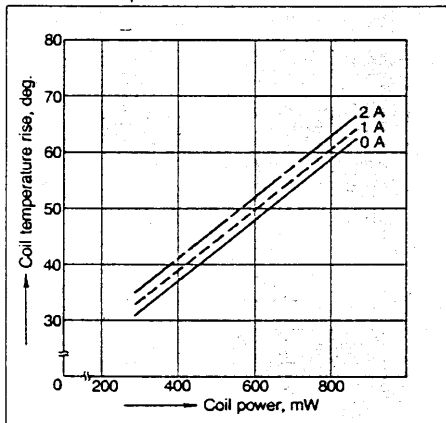

4. Operate and release time characteristics

Tested sample: DSBT-S-DC5V, 10 pcs.
Ambient temperature: 23°C 73°F

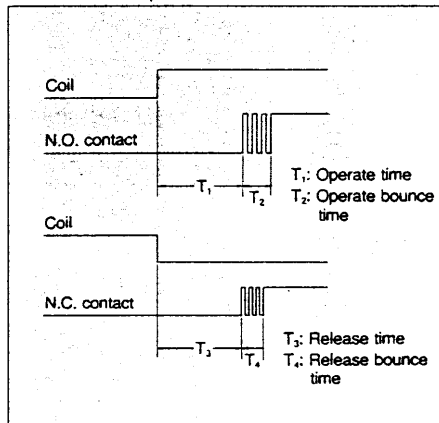

Without diode (T₁)

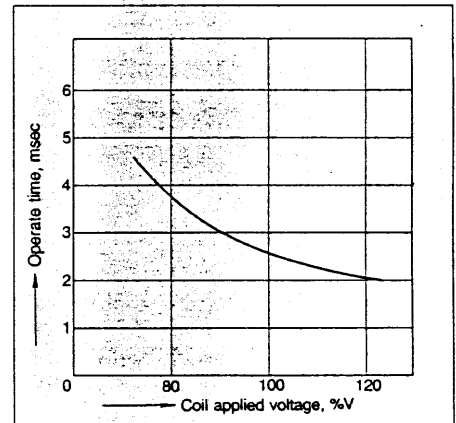

Without diode (T₂)

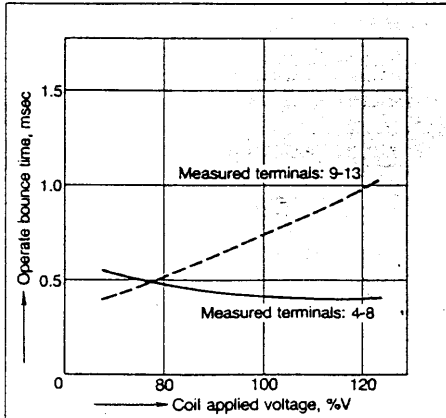

Without diode (T₃)

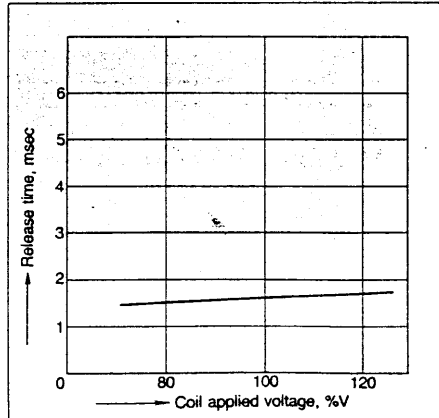

Without diode (T₄)

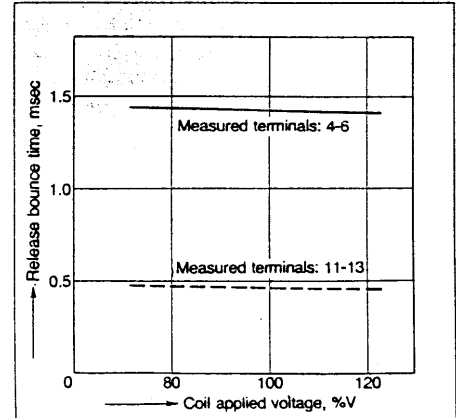

5. Distribution of pick-up and drop-out voltage

Tested sample: DSBT-S-DC5V, 50 pcs.

Pick-up voltage

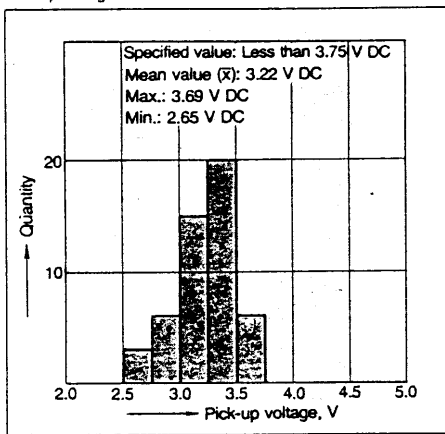

Drop-out voltage

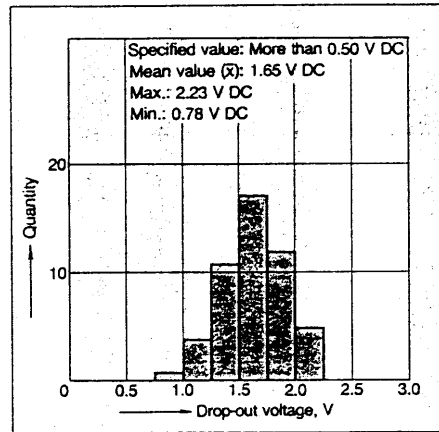

6. Distribution of breakdown voltage (between contacts and coil)

Tested sample: DSBT-S-DC5V, 100 pcs.

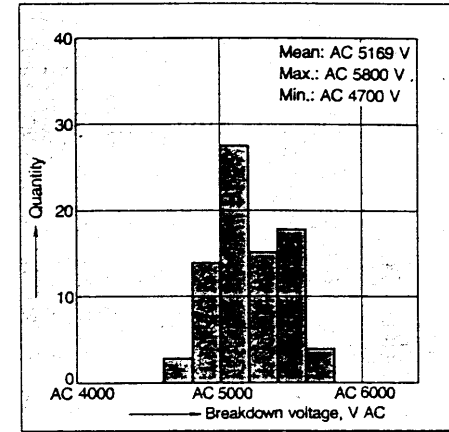

NOTES

1. Coil operating power

Pure DC current should be applied to the coil. And wave form should be rectangular. If it includes ripple, the ripple factor should be less than 5%. However, check it with the actual circuit since the characteristics are slightly different.

2. Coil connection

DSBT relay does not operate with the opposite polarity because DSBT relay is polarized.

3. External magnetic field

Since DSBT relay is polarized relay, its characteristics will be affected by a strong external magnetic field. So avoid using relays under that condition.

4. Cleaning

In automatic cleaning, cleaning with the boiling method is recommended. Avoid ultrasonic cleaning for relays.