

**Technical Specifications**

Rated power, Watts	20
Transformer tapings 100 volt line, Watts	20 /10 /5 /2.5
Transformer impedance, Ohms	500/1k /2k /4k
70.7 volt line, Watts	10/ 5/ 2.5/ 1.25
Driver impedance, Ohms	8
Effective frequency range, Hz (BS6840)	80 - 18,000
S.P. L. ,@ 1m, 1 watt , dB	98
S.P. L. ,@Full power/1m, dB	107
Dispersion at 1,000 Hz, Degrees	140 Vertical, 360 Horizontal
Directivity Q factor, 1k Hz	4.3
Dimensions, mm	φ254
Net weight, Kgs	2.40
Colour / Finish	White
Material	ABS plastic
Mounting	Pendant hung

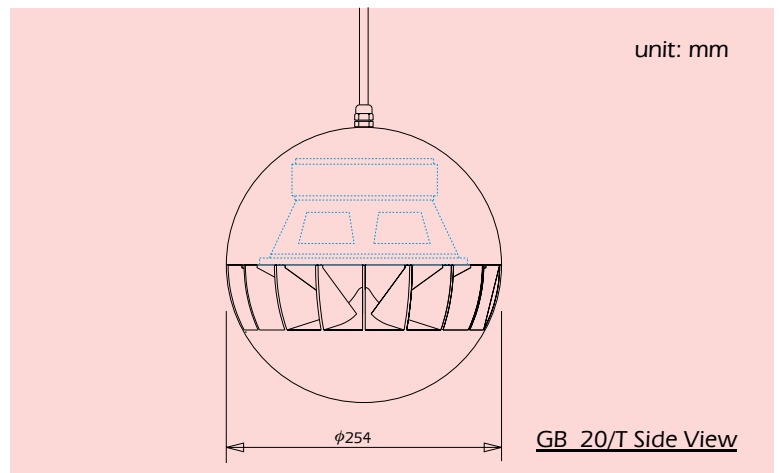

**70.7/25 Volt transformer on request**

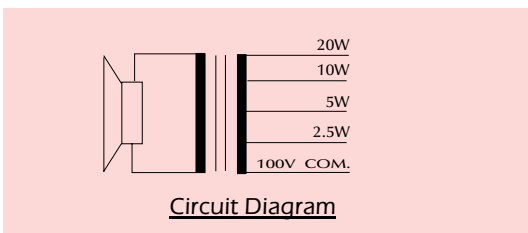

EASE and CATT data are available on request

