

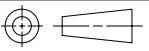

**southco®**

PROPRIETARY ITEM - EXCEPT FOR USES EXPRESSLY GRANTED IN WRITING INFORMATION DISCLOSED HEREON IS CONFIDENTIAL AND ALL RIGHTS PATENT AND OTHERWISE ARE RESERVED BY SOUTHCO, INC.

No. 97 DRAW LATCH ASSEMBLY WITH SPRING SUPPORT

DATE	DRAWN	CHKD	SCALE	DRAWING NUMBER
25SEPT2007	KPL	MJS	1:1	J-97-99-392-M

REV	DATE	DRAWN/CHKD	DESCRIPTION	PART NUMBER	LEVER STYLE	SPRING RATING	SPRING LENGTH	"L" mm	"S" mm	MILLIMETERS
				97-99-392	ACTUATING TAB UP	LIGHT DUTY	MEDIUM	42.1	44.4	
										ALL DIMENSIONS WITHOUT TOLERANCES ARE FOR REFERENCE ONLY.
										 

- NOTES:
- A. SAME AS 97-50-120-11 EXCEPT PACKAGED WITH KEEPER 97-57-103-11 AND KEEPER 97-57-102-11
  - B. MATERIAL AND FINISH
    - 97-99-392
    - 1. LEVER, BASE, AND SPRING AND KEEPERS: STEEL, ZINC PLATE, BRIGHT
    - 2. PIN AND RIVET: STAINLESS STEEL, NATURAL
  - C. HEAD HEIGHT OF MOUNTING SCREWS IN BASE (UNDER SPRING SUPPORT) MUST NOT EXCEED 2.7mm (E.G. SLOTTED PAN HEAD).

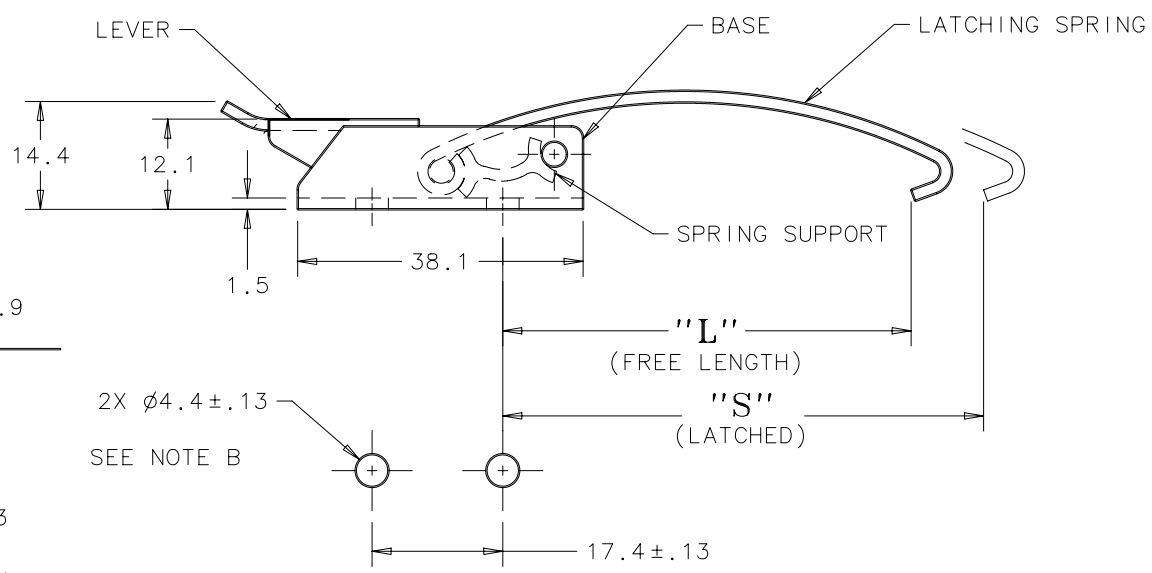
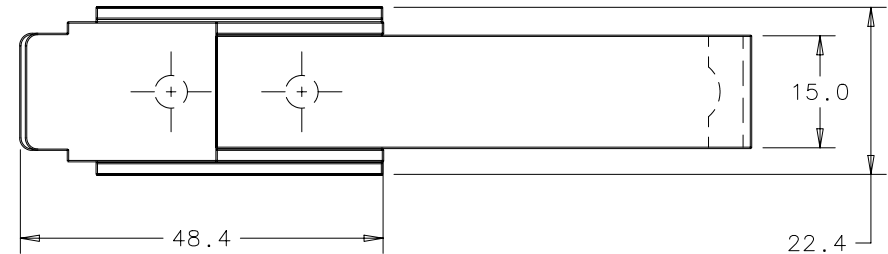
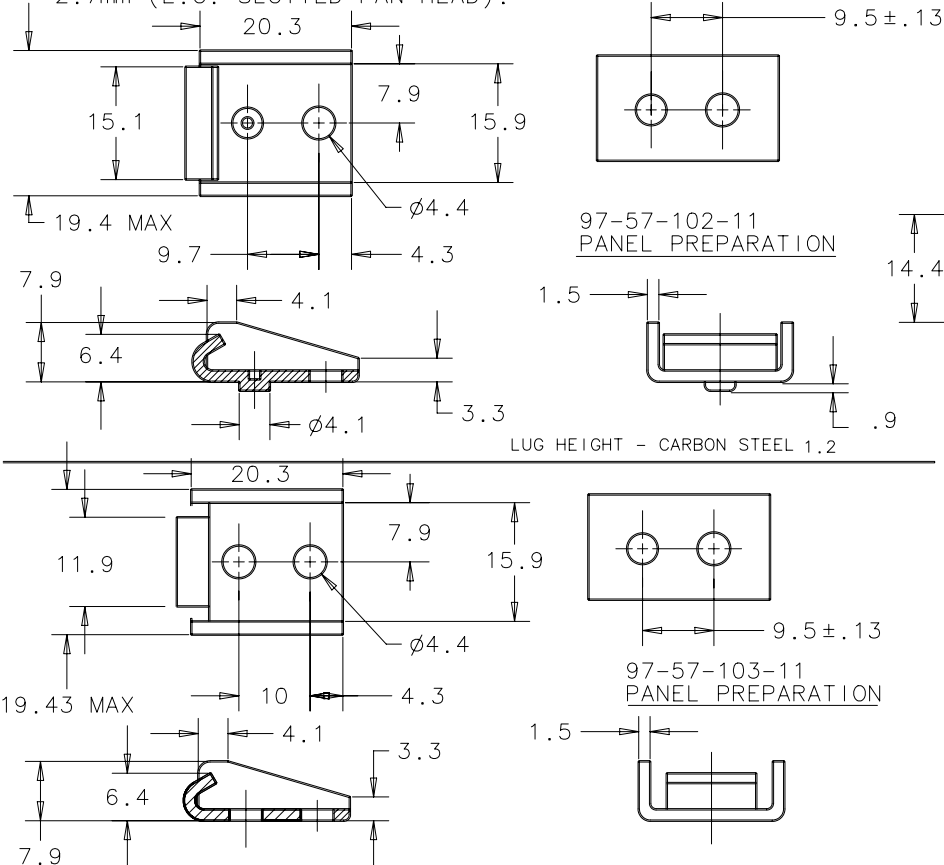

LATCH PANEL PREPARATION