

southco

PROPRIETARY ITEM - EXCEPT FOR USES EXPRESSLY GRANTED IN WRITING INFORMATION DISCLOSED HEREON IS CONFIDENTIAL AND ALL RIGHTS PATENT AND OTHERWISE ARE RESERVED BY SOUTHCO, INC.

E5 QUAD LATCH (TOOL SECURED)
M22 X 23 HOUSING

DATE	DRAWN	CHKD	SCALE	DRAWING NUMBER
10OCT2007	KPL	MJS	1:1	J-E5-99-392

REV	DATE	DRAWN/CHKD	DESCRIPTION
A	27MAR2008	KPL/CHKD	REDESIGNED & REDRAWN.

PART NUMBER: E5-99-39 **W**

ACTUATION STYLE (SEE BELOW)

MILLIMETERS

ALL DIMENSIONS WITHOUT TOLERANCES ARE FOR REFERENCE ONLY.

THIRD ANGLE PROJECTION A3 PAPER SIZE

SHEET 1 OF 2

NOTES:

1. SAME AS E5-6-012-UU1, E5-6-022-UU1, E5-6-062-UU1 OR E5-6-072-UU1 EXCEPT FOUR PAWL GRIPS INCLUDED.
2. SEE SHEET 2 FOR INSTALLATION INSTRUCTIONS.
2. COSMETIC SPECIFICATION: ALL SURFACES CONFORM TO A CLASS "D" DESIGNATION AS DESCRIBED IN SOUTHCO COSMETIC SPECIFICATIONS: S-121-01

SEALING OPTION: O-RING AND GASKET INCLUDED
MATERIAL AND FINISH: DIE CAST ZINC, BRIGHT CHROME PLATE.

W ACTUATION STYLE

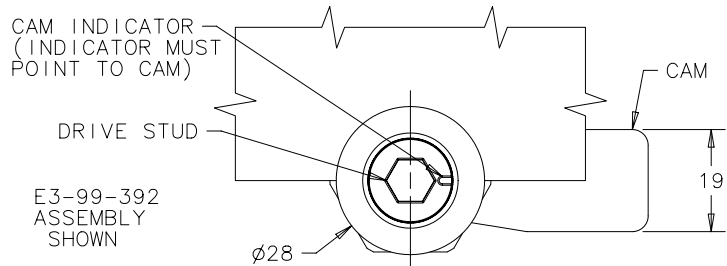
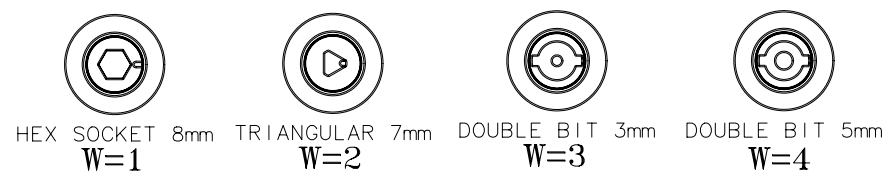

PART NUMBER AND GRIPS OF THE FOUR INCLUDED PAWLS

PAWL PART NUMBER	GRIP
E5-6004	6mm
E5-6007	12mm
E5-6010	18mm
E5-6014	26mm

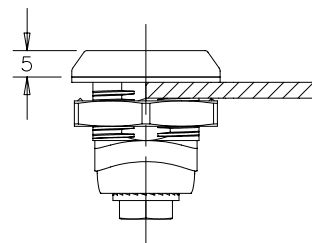
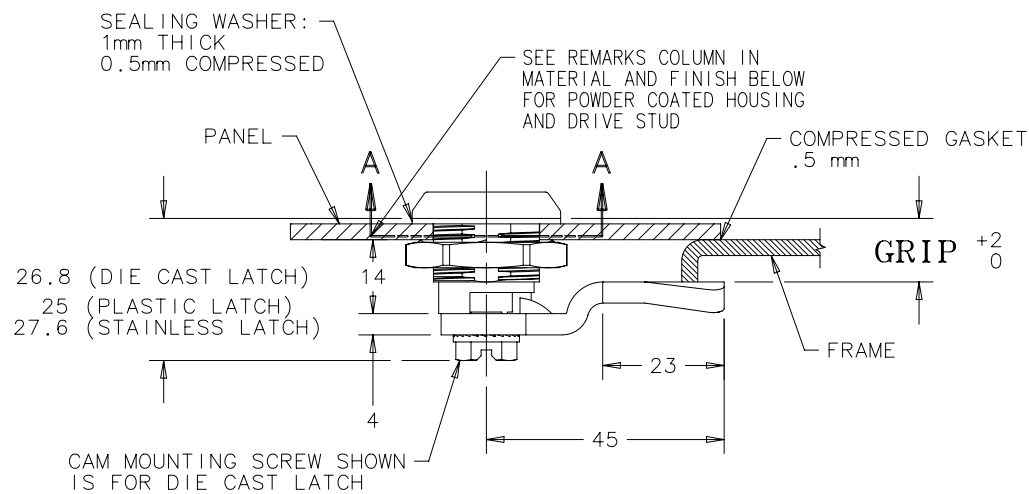

PART NUMBER E5-6-05X-071 SHOWN

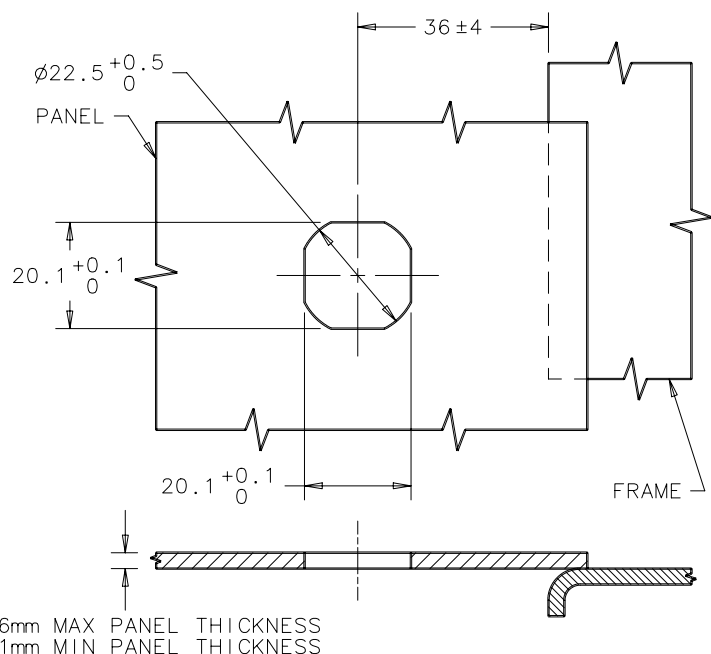

MATERIAL AND FINISH:

DIE CAST ZINC VERSION:

1. HOUSING: DIE CAST ZINC, CHROME PLATED
2. DRIVE STUD: DIE CAST ZINC, CHROME PLATED
3. CAM: STEEL, ZINC PLATE WITH BRIGHT CHROMATE
4. MOUNTING NUT: DIE CAST ZINC
5. CAM MOUNTING SCREW: LOW CARBON STEEL, ZINC PLATE, BRIGHT CHROMATE
6. INTERNAL SPRING: STEEL, ZINC PLATE, BRIGHT CHROMATE
7. O-RING: NITRILE, BLACK
8. SEALING WASHER: POLYURETHANE, BLACK

southco

PROPRIETARY ITEM - EXCEPT FOR USES EXPRESSLY GRANTED IN WRITING INFORMATION DISCLOSED HEREON IS CONFIDENTIAL AND ALL RIGHTS PATENT AND OTHERWISE ARE RESERVED BY SOUTHCO, INC.

E5 QUAD LATCH (TOOL SECURED)
M22 X 23 HOUSING

DATE	DRAWN	CHKD	SCALE	DRAWING NUMBER
10OCT2007	KPL	MJS	1:1	J-E5-99-392

REV	DATE	DRAWN/CHKD	DESCRIPTION
A	27MAR2008	KPL/CHKD	REDESIGNED & REDRAWN.

NOTES:

- SEE SHEET 1 FOR PART NUMBERS, MATERIAL & FINISH AND PANEL PREPARATION.

MILLIMETERS

ALL DIMENSIONS WITHOUT TOLERANCES ARE FOR REFERENCE ONLY.



SHEET 2 OF 2

INSTALLATION METHOD 1

USE WHEN GRIP IS EQUAL TO OR EXCEEDS PANEL THICKNESS BY 9mm.

- PLACE SEALING WASHER ONTO LATCH HOUSING.
- TILT LATCH THROUGH MOUNTING HOLE.
- INSTALL MOUNTING NUT AND TIGHTEN TO:
10 N·m MAX (ZINC VERSION)
4.25 N·m MAX (PLASTIC VERSION)
20 N·m MAX (STAINLESS STEEL VERSION)

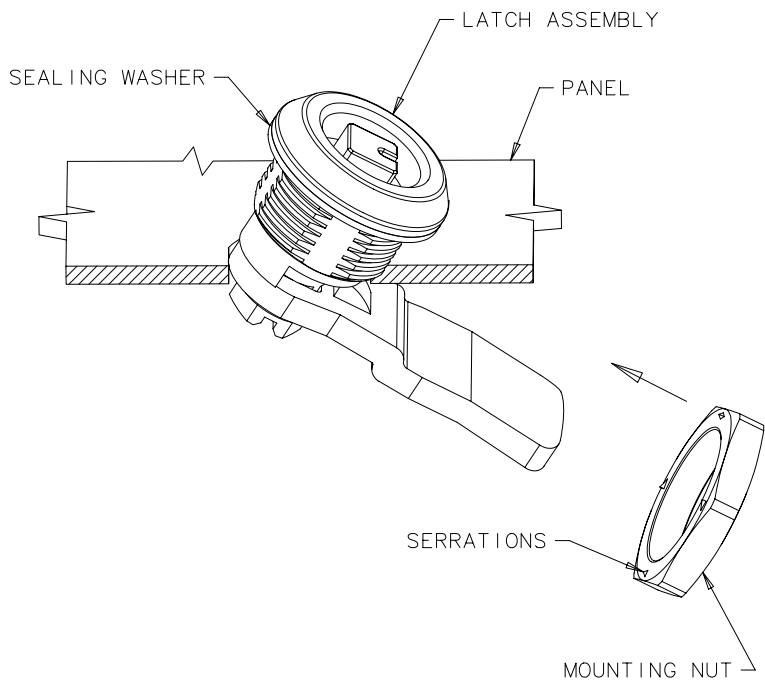

INSTALLATION METHOD 2

REQUIRED WHEN GRIP DOES NOT EXCEED PANEL THICKNESS BY 9mm.

- REMOVE SCREW FROM HOUSING, DETACHING CAM FROM LATCH ASSEMBLY.
- PLACE SEALING WASHER ONTO LATCH HOUSING AND PLACE THROUGH MOUNTING HOLE.
- INSTALL MOUNTING NUT AND TIGHTEN TO:
10 N·m MAX (ZINC VERSION)
4.25 N·m MAX (PLASTIC VERSION)
20 N·m MAX (STAINLESS STEEL VERSION)
- RE-ATTACH CAM TO LATCH ASSEMBLY. ASSURE THAT CAM INDICATOR POINTS TO CAM LOCATION.
- INSTALL SCREW AND TIGHTEN TO:
4 N·m MAX (ZINC VERSION)
3.1 N·m MAX (PLASTIC VERSION)
10 N·m MAX (STAINLESS STEEL VERSION)

FOR PUSH TO CLOSE CAMS, SEE DRAWING J-E5-51.

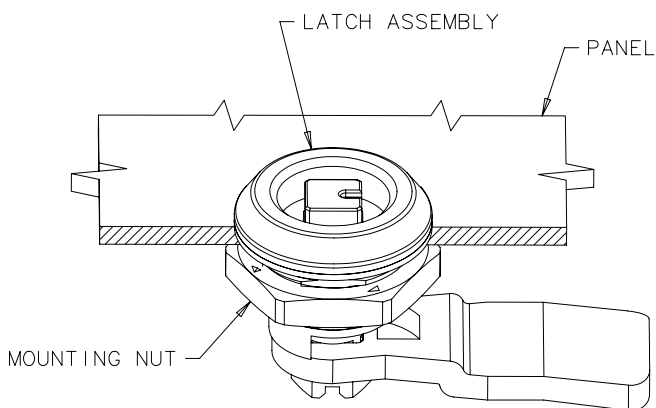
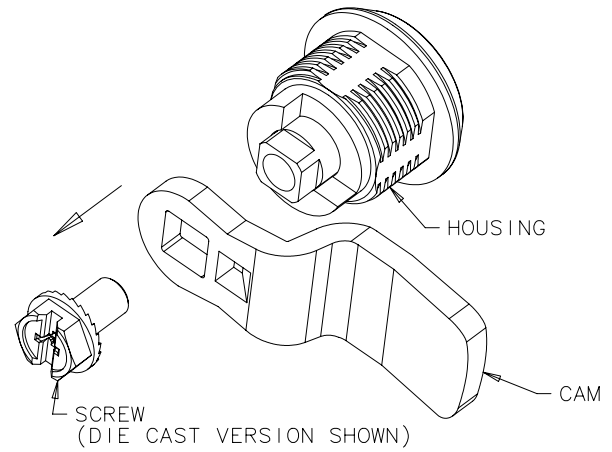

PART NUMBER E5-6-05X-131 SHOWN

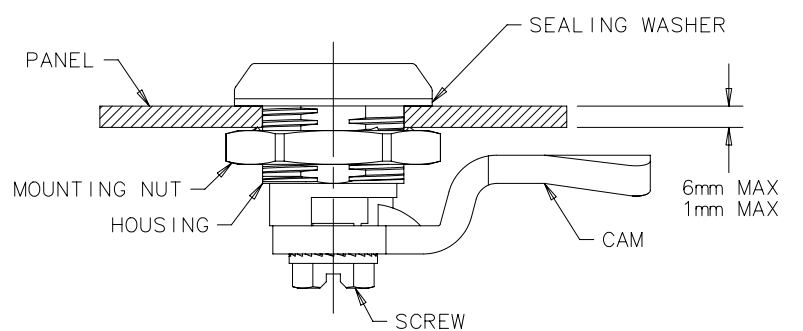
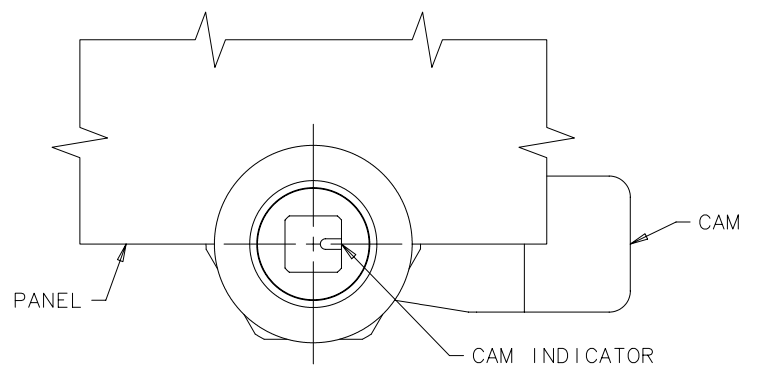
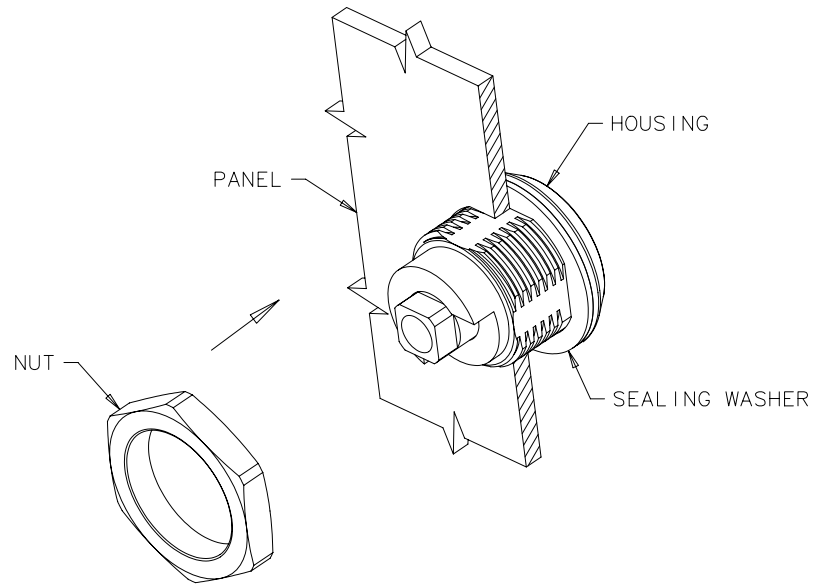
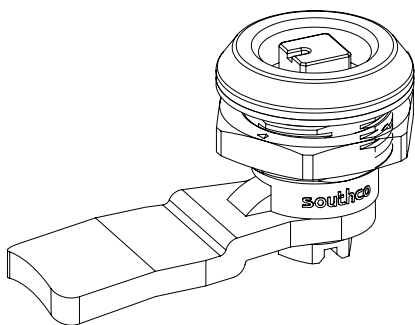

PART NUMBER E5-6-05X-051 SHOWN