

### FEATURES

- BCD coded century, year, month, date, day, hours, minutes, and seconds with automatic leap year compensation valid up to the year 2100
- Programmable watchdog timer and RTC alarm
- Century register; Y2K-compliant RTC
- +3.3 or +5V operation
- Precision power-on reset
- Power control circuitry supports system power-on from date/day/time alarm or key closure/modem detect signal
- 256 bytes user NV SRAM
- Burst mode for reading/writing successive addresses in NV SRAM
- Auxiliary battery input
- Accuracy of DS1511 is better than  $\pm 1$  min./month @ 25°C
- Day of week/date alarm register
- Crystal select bit allows RTC to operate with 6 pF or 12.5 pF crystal
- Battery voltage level indicator flags
- Available as chip (DS1501) or standalone module with embedded battery and crystal (DS1511)
- Optional industrial temperature range -40°C to +85°C (DS1501 only)

### PIN ASSIGNMENT

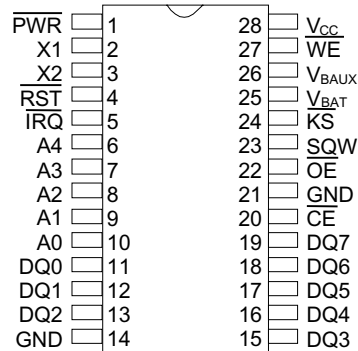

28-Pin DIP, 28-Pin

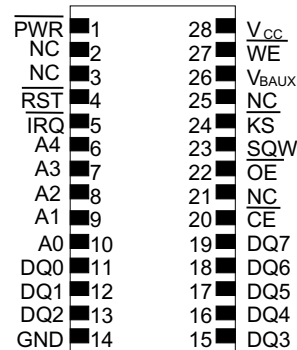

28-Pin Encapsulated Package  
(720-mil FLUSH)



28-Pin TSOP

### ORDERING INFORMATION

DS1501XXX

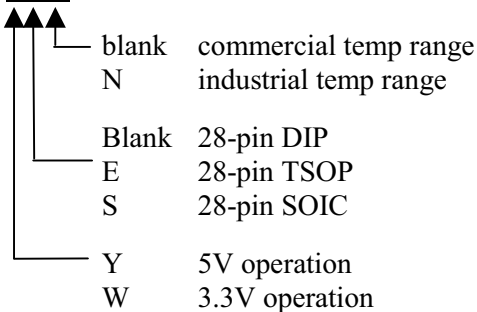

DS1511X Dip Module

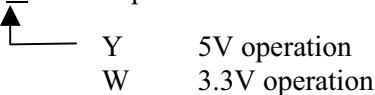

Package Dimension Information can be found at:  
<http://www.dalsemi.com/datasheets/mechdwg.html>

## PIN DESCRIPTION

$V_{CC}$	- Supply Voltage
A0-A4	- Address Inputs
DQ0-DQ7	- Data I/O
$\overline{CE}$	- Chip Enable Input
$\overline{OE}$	- Output Enable Input
$\overline{WE}$	- Write Enable Input
$\overline{IRQ}$	- Interrupt Output (Open Drain)
$\overline{PWR}$	- Power-On Output (Open Drain)
$\overline{RST}$	- Reset Output (Open Drain)
$\overline{KS}$	- Kickstart Input
SQW	- Square Wave Output
$V_{BAT}$	- Backup Battery Supply
$V_{BAUX}$	- Auxiliary Battery Supply
X1, X2	- 32.768 kHz Crystal Pins
GND	- Ground
NC	- No Connection

## DESCRIPTION

The DS1501/DS1511 is a full function, year 2000-compliant, real-time clock/calendar (RTC) with a RTC alarm, watchdog timer, power-on reset, battery monitors, 256 bytes nonvolatile static RAM, and a 32.768 kHz output. User access to all registers within the DS1501 is accomplished with a byte-wide interface as shown in Figure 1. The RTC registers contain century, year, month, date, day, hours, minutes, and seconds data in 24-hour BCD format. Corrections for day of month and leap year are made automatically.

The RTC registers are double buffered into an internal and external set. The user has direct access to the external set. Clock/calendar updates to the external set of registers can be disabled and enabled to allow the user to access static data. When the crystal oscillator is turned on, the internal set of registers are continuously updated; this occurs regardless of external register settings to guarantee that accurate RTC information is always maintained.

The DS1501/DS1511 contains its own power fail circuitry which automatically deselects the device when the  $V_{CC}$  supply falls below a power fail trip point. This feature provides a high degree of data security during unpredictable system operation brought on by low  $V_{CC}$  levels

The DS1501/DS1511 has interrupt ( $\overline{IRQ}$ ), power control ( $\overline{PWR}$ ), and reset ( $\overline{RST}$ ) outputs which can be used to control CPU activity. The  $\overline{IRQ}$  interrupt or  $\overline{RST}$  outputs can be invoked as the result of a time of day alarm, CPU watchdog alarm, or a kick start signal. The DS1501/1511 power control circuitry allows the system to be powered on via an external stimulus, such as a keyboard or by a time and date (wake-up) alarm. The  $\overline{PWR}$  output pin can be triggered by one or either of these events, and can be used to turn on an external power supply. The  $\overline{PWR}$  pin is under software control, so that when a task is complete, the system power can then be shut down. The DS1501/DS1511 power-on reset can be used to detect a system power down or failure and hold the CPU in a safe reset state until normal power returns and stabilizes; the  $\overline{RST}$  output is used for this function.

The DS1501 is a clock/calendar chip with the features described above. An external crystal and battery are the only components required to maintain time-of-day and memory status in the absence of power.

The DS1511 incorporates the DS1501 chip, a 32.768 kHz crystal, and a lithium battery in a complete, self-contained timekeeping module. The entire unit is designed by Dallas Semiconductor to provide a minimum of 10 years of timekeeping and data retention in the absence of  $V_{CC}$ .

## DS1501/DS1511 BLOCK DIAGRAM Figure 1

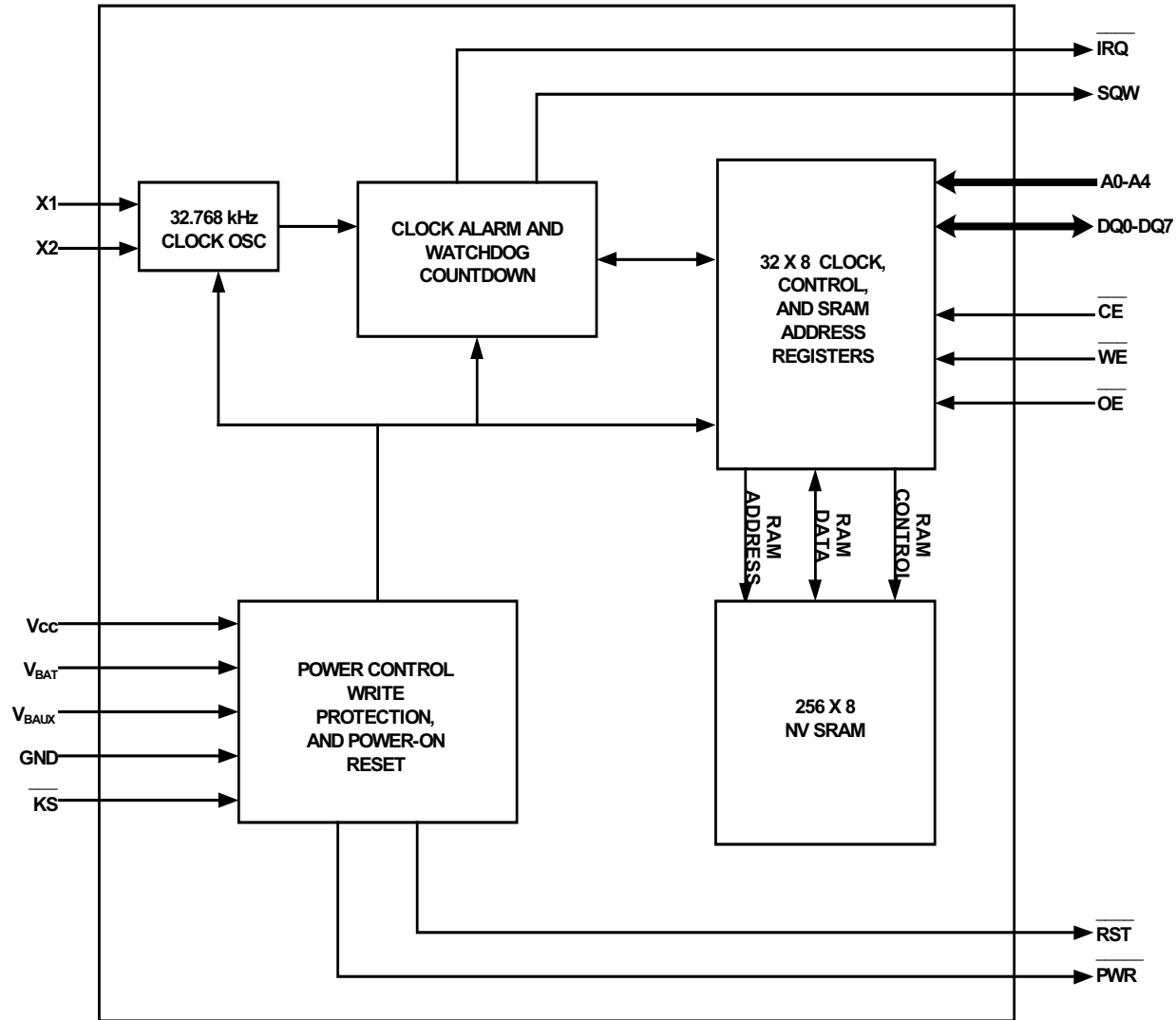

## DS1501/DS1511 OPERATING MODES Table 1

$V_{CC}$	$\overline{CE}$	$\overline{OE}$	$\overline{WE}$	DQ0-DQ7	A0-A4	MODE	POWER
IN TOLERANCE	$V_{IH}$	X	X	HIGH-Z	X	DESELECT	STANDBY
	$V_{IL}$	X	$V_{IL}$	$D_{IN}$	$A_{IN}$	WRITE	ACTIVE
	$V_{IL}$	$V_{IL}$	$V_{IH}$	$D_{OUT}$	$A_{IN}$	READ	ACTIVE
	$V_{IL}$	$V_{IH}$	$V_{IH}$	HIGH-Z	$A_{IN}$	READ	ACTIVE
$V_{SO} < V_{CC} < V_{PF}$	X	X	X	HIGH-Z	X	DESELECT	CMOS STANDBY
$V_{CC} < V_{SO} < V_{PF}$	X	X	X	HIGH-Z	X	DATA RETENTION	BATTERY CURRENT

## DATA READ MODE

The DS1501/DS1511 is in the read mode whenever  $\overline{CE}$  (chip enable) is low and  $\overline{WE}$  (write enable) is high. The device architecture allows ripple-through access to any valid address location. Valid data will be available at the DQ pins within  $t_{AA}$  (Address Access) after the last address input is stable, providing that  $\overline{CE}$  and  $\overline{OE}$  access times are satisfied. If  $\overline{CE}$  or  $\overline{OE}$  access times are not met, valid data will be available at the latter of chip enable access ( $t_{CEA}$ ) or at output enable access time ( $t_{OEA}$ ). The state of the data input/output pins (DQ) is controlled by  $\overline{CE}$  and  $\overline{OE}$ . If the outputs are activated before  $t_{AA}$ , the data lines are driven to an intermediate state until  $t_{AA}$ . If the address inputs are changed while  $\overline{CE}$  and  $\overline{OE}$  remain valid, output data will remain valid for output data hold time ( $t_{OH}$ ) but will then go indeterminate until the next address access. (See Table 1.)

## DATA WRITE MODE

The DS1501/DS1511 is in the write mode whenever  $\overline{WE}$  and  $\overline{CE}$  are in their active state. The start of a write is referenced to the latter occurring transition of  $\overline{WE}$  or  $\overline{CE}$ . The addresses must be held valid throughout the cycle.  $\overline{CE}$  or  $\overline{WE}$  must return inactive for a minimum of  $t_{WR}$  prior to the initiation of a subsequent read or write cycle. Data in must be valid  $t_{DS}$  prior to the end of the write and remain valid for  $t_{DH}$  afterward. In a typical application, the  $\overline{OE}$  signal will be high during a write cycle. However,  $\overline{OE}$  can be active provided that care is taken with the data bus to avoid bus contention. If  $\overline{OE}$  is low prior to a high to low transition on  $\overline{WE}$ , the data bus can become active with read data defined by the address inputs. A low transition on  $\overline{WE}$  will then disable the outputs  $t_{WEZ}$  after  $\overline{WE}$  goes active. (See Table 1.)

## DATA RETENTION MODE

The DS1501/DS1511 is fully accessible and data can be written and read only when  $V_{CC}$  is greater than  $V_{PF}$ . However, when  $V_{CC}$  falls below the power-fail point  $V_{PF}$  (point at which write protection occurs) the internal clock registers and SRAM are blocked from any access. While in the data retention mode, all inputs are don't cares and outputs go to a high-Z state, with the possible exception of  $\overline{KS}$ ,  $\overline{PWR}$ ,  $SQW$ , and  $\overline{RST}$ . If  $V_{PF}$  is less than  $V_{BAT}$  and  $V_{BAUX}$ , the device power is switched from  $V_{CC}$  to the greater of  $V_{BAT}$  and  $V_{BAUX}$  when  $V_{CC}$  drops below  $V_{PF}$ . If  $V_{PF}$  is greater than  $V_{BAT}$  and  $V_{BAUX}$ , the device power is switched from  $V_{CC}$  to the larger of  $V_{BAT}$  and  $V_{BAUX}$  when  $V_{CC}$  drops below the larger of  $V_{BAT}$  and  $V_{BAUX}$ . RTC operation and SRAM data are maintained from the battery until  $V_{CC}$  is returned to nominal levels. (See Table 1.)

All control, data, and address signals must be no more than 0.3 volts above  $V_{CC}$ .

## AUXILIARY BATTERY

The  $V_{BAUX}$  input is provided to supply power from an auxiliary battery for the DS1501/DS1511 kickstart and  $SQW$  output features in the absence of  $V_{CC}$ . This power source must be available in order to use these auxiliary features when  $V_{CC}$  is not applied to the device.

This auxiliary battery may be used as the primary backup power source for maintaining the clock/calendar and extended user RAM. This occurs if the  $V_{BAT}$  pin is at a lower voltage than  $V_{BAUX}$ . If the DS1501/DS1511 is to be backed-up using a single battery with the auxiliary features enabled, then  $V_{BAUX}$  should be used and  $V_{BAT}$  should be grounded. If  $V_{BAUX}$  is not to be used, it should be grounded.

---

## POWER-ON RESET

A temperature compensated comparator circuit monitors the level of  $V_{CC}$ . When  $V_{CC}$  falls to the power fail trip point, the  $\overline{RST}$  signal (open drain) is pulled low. When  $V_{CC}$  returns to nominal levels, the  $\overline{RST}$  signal continues to be pulled low for a period of 40 ms to 200 ms. The power on reset function is independent of the RTC oscillator and thus is operational whether or not the oscillator is enabled.

**DS1501/DS1511 REGISTER MAP Table 2**

Address	DATA								Function	BCD Range
	B7	B6	B5	B4	B3	B2	B1	B0		
00H	0	10 SECONDS			SECONDS				Seconds	00-59
01H	0	10 MINUTES			MINUTES				Minutes	00-59
02H	0	0	10 HOURS		HOUR				Hours	00-23
03H	0	0	0	0	0	DAY			Day	1-7
04H	0	0	10 DATE		DATE				Date	01-31
05H	$\overline{\text{EOSC}}$	$\overline{\text{E32K}}$	BB32	10 MO	MONTH				Month	01-12
06H	10 YEAR				YEAR				Year	00-99
07H	10 CENTURY				CENTURY				Century	00-39
08H	AM1	10 SECONDS			SECONDS				Alarm Seconds	00-59
09H	AM2	10 MINUTES			MINUTES				Alarm Minutes	00-59
0AH	AM3	0	10 HOURS		HOUR				Alarm Hours	00-23
0BH	AM4	DY/DT	10 DATE		DAY / DATE				Alarm Day / Date	1-7 / 1-31
0CH	0.1 SECOND				0.01 SECOND				Watchdog	00-99
0DH	10 SECOND				SECOND				Watchdog	00-99
0EH	BLF1	BLF2	PRS	PAB	TDF	KSF	WDF	IRQF	Control A	
0FH	TE	CS	BME	TPE	TIE	KIE	WDE	WDS	Control B	
10H	EXTENDED RAM ADDRESS								RAM ADDR LSB	00-FF
11H	RESERVED									
12H	RESERVED									
13H	EXTENDED RAM DATA								RAM DATA	00-FF
14H	RESERVED									
15H	RESERVED									
16H	RESERVED									
17H	RESERVED									
18H	RESERVED									
19H	RESERVED									
1AH	RESERVED									
1BH	RESERVED									
1CH	RESERVED									
1DH	RESERVED									
1EH	RESERVED									
1FH	RESERVED									

0 = "0" and are read only

**NOTE:** Unless otherwise specified, the state of the control/RTC/SRAM bits in the DS1501/DS1511 is not defined upon initial power application; the DS1501/DS1511 should be properly configured/defined during initial configuration.

## CONTROL REGISTERS

The controls and status information for the features offered by the DS1501/DS1511 are maintained in the following register bits.

### $\overline{EOSC}$ - Oscillator Start/Stop Bit (05H bit 7)

This bit is used to turn the oscillator on and off.

"1" - oscillator off

"0" - oscillator on

The oscillator is automatically turned on by the internal Power on Reset when power is applied and  $V_{CC}$  rises above the Power-fail Voltage.

### $\overline{E32K}$ - Enable 32.768kHz Output (05H bit 6)

This bit, when written to a "0", will enable the 32.768 kHz oscillator frequency to be output on the SQW pin if the oscillator is running. This bit is automatically cleared to a logic "0" to by the internal Power on Reset when power is applied and  $V_{CC}$  rises above the Power-fail Voltage.

### BB32 - Battery Backup 32kHz Enable Bit (05H bit 5)

When the BB32 bit is written to a "1", it will enable a 32kHz signal to be output on the SQW pin while the part is in battery backup mode if voltage is applied to  $V_{BAUX}$ .

### AM1-AM4 - Alarm Mask Bits (08H bit 7; 09H bit 7; 0AH bit 7; 0BH bit 7)

Bit 7 of registers 08h to 0Bh contains an alarm mask bit: AM1 to AM4. These bits, in conjunction with the TIE described later, allow the  $\overline{IRQ}$  output to be activated for a matched alarm condition.

The alarm can be programmed to activate on a specific day of the month, day of the week, or repeat every day, hour, minute, or second. Table 3 shows the possible settings for AM1 - AM4 and the resulting alarm rates. Configurations not listed in the table default to the once per second mode to notify the user of an incorrect alarm setting.

### DY/DT - Day/Date Bit (0BH bit 6)

The DY/DT bit controls whether the alarm value stored in bits 0 to 5 of 0BH reflects the day of the week or the date of the month. If DY/DT is written to a "0", the alarm will be the result of a match with the date of the month. If DY/DT is written to a "1", the alarm will be the result of a match with the day of the week.

### BLF1 - Valid RAM and Time Bit 1 (0EH bit 7)

### BLF2 - Valid RAM and Time Bit 2 (0EH bit 6)

These status bits gives the condition of any batteries attached to the  $V_{BAT}$  or  $V_{BAUX}$  pins. The DS1501/DS1511 constantly monitors the battery voltage of the back-up battery sources ( $V_{BAT}$  and  $V_{BAUX}$ ). The BLF1 and BLF2 bits will be set to a "1" if the battery voltage on  $V_{BAT}$  and  $V_{BAUX}$  are less than 2.5V (typical), otherwise BLF1 and BLF2 bits will be a "0". BLF1 reflects the condition of  $V_{BAT}$  with BLF2 reflecting  $V_{BAUX}$ . If either bit is read as a "1", the voltage on the respective pin is inadequate to maintain the RAM memory or clock functions.

### PRS - PAB Reset Select Bit (0EH bit 5)

When set to a "0" the PWR pin will be set hi-Z when the DS1501/DS1511 goes into power fail. When set to a "1", the PWR pin will remain active upon entering power fail.

**PAB - Power Active Bar Control Bit** (0EH bit 4)

When this bit is "0", the  $\overline{\text{PWR}}$  pin is in the active low state. When this bit is "1", the  $\overline{\text{PWR}}$  pin is in the high impedance state. This bit can be written to a "1" or "0" by the user. If either TDF AND TPE = "1" OR KSF = "1", the PAB bit will be cleared to a "0".

**TDF - Time of Day/Date Alarm Flag** (0EH bit 3)

A "1" in the TDF bit indicates that the current time has matched the alarm time. If the TIE bit is also a "1", the  $\overline{\text{IRQ}}$  pin will go low and a "1" will appear in the IRQF bit.

**KSF - Kickstart Flag** (0EH bit 2)

This bit is set to a "1" when a kickstart condition occurs or when the user writes it to a "1". This bit is cleared by writing it to a "0".

**WDF - Watchdog Flag** (0EH bit 1)

If the processor does not access the DS1501/DS1511 with a write within the period specified in addresses 0CH and 0DH, the WDF bit will be set to a "1". WDF is cleared by writing it to a "0".

**IRQF - Interrupt Request Flag** (0EH bit 0)

The Interrupt Request Flag (IRQF) bit is set to a "1" when one or more of the following are true:

TDF = TIE = "1"

KSF = KIE = "1"

WDF = WDE = "1"

i.e.,  $\text{IRQF} = (\text{TDF} \cdot \text{TIE}) + (\text{KSF} \cdot \text{KIE}) + (\text{WDF} \cdot \text{WDE})$

Any time the IRQF bit is a "1", the  $\overline{\text{IRQ}}$  pin is driven low.

**TE - Transfer Enable Bit** (0FH bit 7)

When the TE bit is a "1", the update transfer functions normally by advancing the counts once per second. When the TE bit is written to a "0", any update transfer is inhibited and the program can initialize the time and calendar bytes without an update occurring in the midst of initializing. Read cycles can be executed in a similar manner. TE is a read/write bit that is not modified by internal functions of the DS1501/DS1511.

**CS - Crystal Select Bit** (0FH bit 6)

When CS is set to a "0", the oscillator is configured for operation with a crystal that has a 6 pF specified load capacitance. When CS="1", the oscillator is configured for a 12.5 pF crystal. CS is disabled in the DS1511 module and should be set to CS="0".

**BME - Burst Mode Enable Bit** (0FH bit 5)

The burst mode enable bit allows the extended user RAM address registers to automatically increment for consecutive reads and writes. When BME is set to a "1", the automatic incrementing will be enabled and when BME is set to a "0", the automatic incrementing will be disabled.

**TPE - Time of Day/Date Alarm Power Enable Bit** (0FH bit 4)

The wake up feature is controlled through the TPE bit. When the TDF flag bit is set to a "1", if TPE is a "1", the  $\overline{\text{PWR}}$  pin will be driven active. Therefore, setting TPE to "1" enables the wake up feature. Writing a "0" to TPE disables the wake up feature.



**TIE - Time of Day/Date Alarm Interrupt Enable Bit (0FH bit 3)**

The TIE bit allows the TDF Flag to assert an Interrupt. When the TDF flag bit is set to a "1", if TIE is a "1", the IRQF flag bit will be set to a "1". Writing a "0" to the TIE bit will prevent the TDF flag from setting the IRQF flag. This bit is automatically cleared to a logic "0" to by the internal Power on Reset when power is applied and Vcc rises above the Power-fail Voltage.

**KIE - Kickstart Enable Interrupt Bit (0FH bit 2)**

The KIE bit allows the KSF Flag to assert an interrupt. When the KSF flag bit is set to a "1", if KIE is a "1", the IRQF flag bit will be set to a "1". Writing a "0" to the KIE bit will prevent the KSF flag from setting the IRQF flag. This bit is automatically cleared to a logic "0" to by the internal Power on Reset when power is applied and Vcc rises above the Power-fail Voltage.

**WDE - Watchdog Enable Bit (0FH bit 1)**

When WDE is set to a "1", the Watchdog function is enabled and either the  $\overline{\text{IRQ}}$  or  $\overline{\text{RST}}$  pin will be pulled active based on the state of the WDS bit. This bit is automatically cleared to a logic "0" to by the internal Power on Reset when power is applied and Vcc rises above the Power-fail Voltage.

**WDS - Watchdog Steering Bit (0FH bit 0)**

If WDS is a "0" when the Watchdog Flag Bit WDF is set to a "1", the  $\overline{\text{IRQ}}$  pin will be pulled low. If WDS is a "1" when WDF is set to a "1", the watchdog will output a negative pulse on the  $\overline{\text{RST}}$  output for a duration of 40 ms to 200 ms and the 'IRQF' flag will be set when the watchdog times out. The WDE bit will reset to a "0" immediately after  $\overline{\text{RST}}$  goes active. This bit is automatically cleared to a logic "0" to by the internal Power on Reset when power is applied and Vcc rises above the Power-fail Voltage.

**CLOCK OSCILLATOR CONTROL**

The Clock oscillator may be stopped at any time. To increase the shelf life of a backup lithium battery source, the oscillator can be turned off to minimize current drain from the battery. The  $\overline{\text{EOSC}}$  bit is used to control state of the oscillator, and must be set to a "0" for the oscillator to function.

**READING THE CLOCK**

When reading the clock and calendar data, it is recommended to halt updates to the external set of double buffered RTC registers. This puts the external registers into a static state allowing data to be read without register values changing during the read process. Normal updates to the internal registers continue while in this state. External updates are halted when a "0" is written into the Transfer Enable, TE, bit of Control register B (0Fh). As long as a "0" remains in the Control register B (TE) bit, updating is halted. After a halt is issued, the registers reflect the RTC count (day, date, and time) that was current at the moment the halt command was issued. Normal updates to the external set of registers will resume within 1 second after the (TE) bit is set to a "1".

**SETTING THE CLOCK**

It is also recommended to halt updates to the external set of double buffered RTC registers when writing to the clock. The (TE) bit should be used as described above before loading the RTC registers with the desired RTC count (day, date, and time) in 24-hour BCD format. Setting the (TE) bit to a "1" will transfer the new values written, to the internal RTC registers and allow normal operation to resume.

## CLOCK ACCURACY

A standard 32.768 kHz quartz crystal should be directly connected to the DS1501 X1 and X2 oscillator pins. The crystal selected for use should have a specified load capacitance ( $C_L$ ) of either 6 pF or 12.5 pF, and the Crystal Select (CS) bit set accordingly. For more information on crystal selection and crystal layout considerations, please consult Application Note 58, "Crystal Considerations with Dallas Real Time Clocks." The DS1501 can also be driven by an external 32.768 kHz oscillator. In order to achieve low power operation when using an external oscillator, it may be necessary to connect the X1 pin to the external oscillator signal through a series connection consisting of a resistor and a capacitor. A typical configuration consists of a 1.0Meg resistor in series with a 100pf ceramic capacitor. When using an external oscillator the X2 pin must be left open. Accuracy of DS1511 is better than  $\pm 1$  min./month at 25°C.

## USING THE CLOCK ALARM

The alarm settings and control for the DS1501/DS1511 reside within registers 08h - 0Bh (see Table 2). The TIE bit and alarm mask bits AM1-AM4 must be set as described below for the  $\overline{\text{IRQ}}$  or PWR outputs to be activated for a matched alarm condition.

The alarm can be programmed to activate on a specific day of the month, day of the week, or repeat every day, hour, minute, or second. It can also be programmed to go off while the DS1501/DS1511 is in the battery-backed state of operation to serve as a system wake-up. Alarm mask bits AM1-AM4 control the alarm mode. Table 3 shows the possible settings. Configurations not listed in the table default to the once per second mode to notify the user of an incorrect alarm setting. When the RTC register values match alarm register settings, the Time of Day/Date alarm Flag TDF bit is set to a "1". Once the TDF flag is set, the TIE bit enables the alarm to activate the  $\overline{\text{IRQ}}$  pin. The TPE bit enables the alarm flag to activate the PWR pin.

### ALARM MASK BITS Table 3

DY/DT	AM4	AM3	AM2	AM1	ALARM RATE
X	1	1	1	1	Once per Second
X	1	1	1	0	When seconds match
X	1	1	0	0	When minutes and seconds match
X	1	0	0	0	When hours, minutes, and seconds match
0	0	0	0	0	When date, hours, minutes, and seconds match
1	0	0	0	0	When day, hours, minutes, and seconds match

## USING THE WATCHDOG TIMER

The watchdog timer can be used to restart an out-of-control processor. The watchdog timer is user programmable in 10 milli-second intervals ranging from 0.01 seconds to 99.99 seconds. The user programs the watchdog timer by setting the desired amount of time-out into the two BCD Watchdog Registers (Address 0Ch and 0Dh). For example: writing 60h in the watchdog register 0Ch and 00h to watchdog register 0Dh will set the watchdog time-out to 600 milli-seconds. If the processor does not access the timer with a write within the specified period, both the Watchdog Flag WDF and the Interrupt Request Flag IRQF will be set. If the Watchdog Enable bit WDE is enabled, then either  $\overline{\text{IRQ}}$  or  $\overline{\text{RST}}$  will go active depending on the state of the Watchdog Steering Bit WDS. The watchdog will be reloaded and restarted whenever the watchdog times out. The WDF bit will be set to a "1" regardless of the state of WDE to serve as an indication to the processor that a watchdog time out has occurred.

The watchdog timer is reloaded when the processor performs a write of the Watchdog registers. The time-out period then starts over. The watchdog timer is disabled by writing a value of 00h to both watchdog registers. The watchdog function is automatically disabled upon power-up by the POWER on RESET setting WDE=0 and WDS=0. The watchdog registers are not initialized at power up and should be initialized by the user.

The following summarizes the configurations in which the watchdog can be used.

1. **WDE=0 and WDS=0:** WDF will be set.
2. **WDE=0 and WDS=1:** WDF will be set.
3. **WDE=1 and WDS=0:** WDF and IRQF will be set, and the  $\overline{\text{IRQ}}$  pin will be pulled low.
4. **WDE=1 and WDS=1:** WDF will be set, the  $\overline{\text{RST}}$  pin will be pulled low for a duration of 40 ms to 200 ms, and 'WDE' will be reset to '0'.

## CLEARING IRQ AND FLAGS

The Time of Day/Date Alarm Flag (TDF), Watchdog Flag (WDF), and Interrupt Request Flag (IRQF), are cleared by reading the flag register (0EH) as shown in Figures 2a, 2b, and 2c. The address must be stable for a minimum of 15 ns ( $t_{\text{IRQZ}}$ ). After the  $t_{\text{IRQZ}}$  requirement has been met, either a change in address (figure 2a), a rising edge of  $\overline{\text{OE}}$  (figure 2b), or a rising edge of  $\overline{\text{CS}}$  (Figure 2c) will cause the flags to be cleared. The  $\overline{\text{IRQ}}$  pin will go inactive after the IRQF flag is cleared.

## IRQ AND FLAG WAVEFORMS (ADDRESS RELATED) Figure 2a

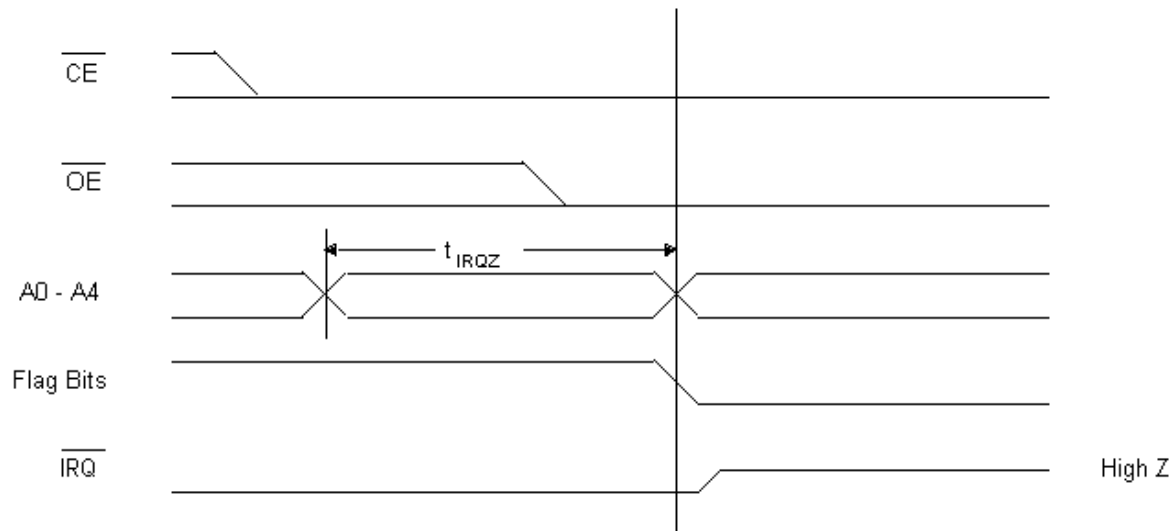

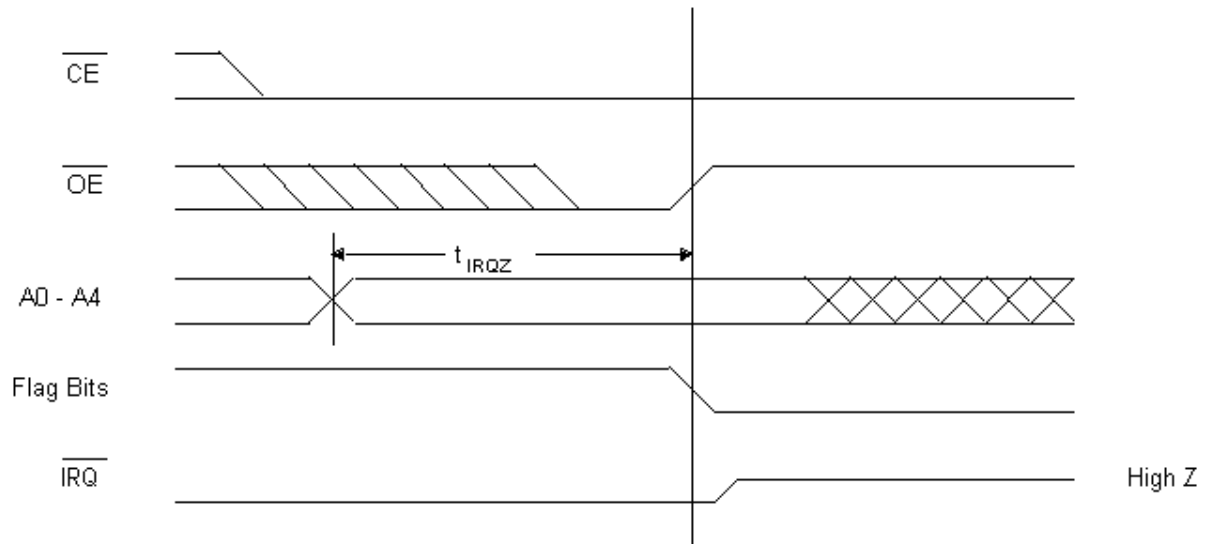
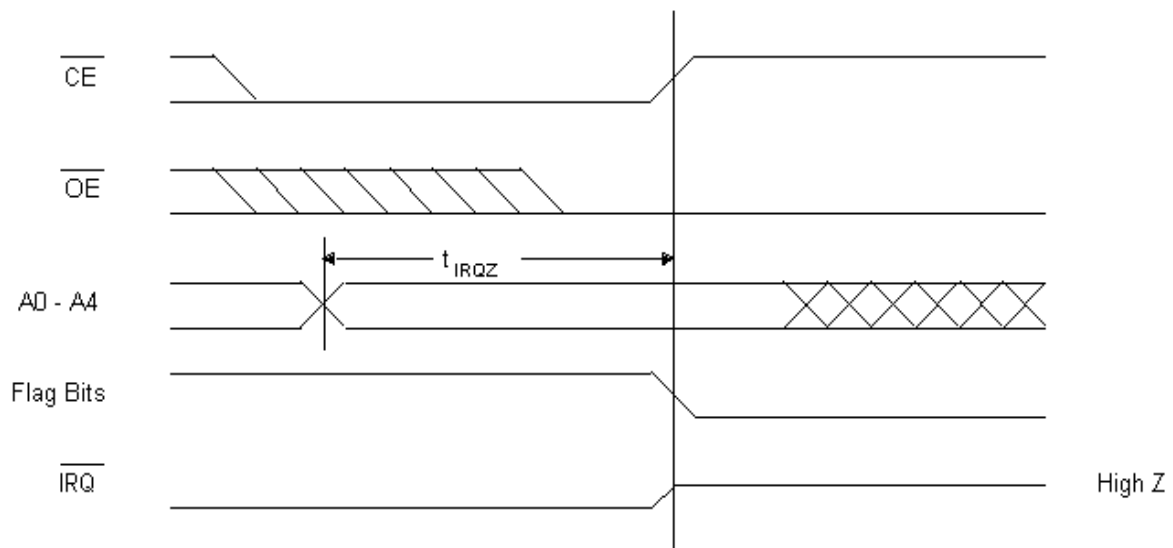
**IRQ AND FLAG WAVEFORMS ( $\overline{\text{OE}}$  RELATED) Figure 2b****IRQ AND FLAG WAVEFORMS ( $\overline{\text{CE}}$  RELATED) Figure 2c**

## WAKE UP/KICKSTART

The DS1501/DS1511 incorporates a wake up feature that can power the system on at a pre-determined day/date and time through activation of the  $\overline{\text{PWR}}$  output pin. In addition, the kickstart feature can allow the system to be powered up in response to a high to low transition on the  $\overline{\text{KS}}$  pin, without operating voltage applied to the  $V_{\text{CC}}$  pin. As a result, system power may be applied upon such events as key closure, or a modem ring detect signal. In order to use the kickstart features, the DS1501/DS1511 must have an auxiliary battery connected to the  $V_{\text{BAUX}}$  pin. The oscillator must be running to make use of the wakeup feature.

The wake up feature is controlled through the Time of Day/Date Power Enable bit TPE. Setting TPE to "1" enables the wake up feature. Writing TPE to a "0" disables the wake up feature. The kickstart feature is always enabled as long as  $V_{\text{BAUX}}$  is present.

If the wake up feature is enabled, while the system is powered down (no  $V_{\text{CC}}$  voltage), the clock/calendar will monitor the current day or date for a match condition with day/date alarm register (0Bh). In conjunction with the day/date alarm register, the hours, minutes, and seconds alarm bytes in the clock calendar register map (02h, 01h, and 00h) are also monitored. As a result, a wake up will occur at the day or date and time specified by the day/date, hours, minutes, and seconds alarm register values. This additional alarm will occur regardless of the programming of the TIE bit. When the match condition occurs, the  $\overline{\text{PWR}}$  pin will automatically be driven low. This output can be used to turn on the main system power supply that provides  $V_{\text{CC}}$  voltage to the DS1501/DS1511 as well as the other major components in the system. Also, at this time, the Time of Day/Date alarm Flag, TDF, will be set, indicating that a wake up condition has occurred.

If  $V_{\text{BAUX}}$  is present, while  $V_{\text{CC}}$  is low, the  $\overline{\text{KS}}$  input pin will be monitored for a low going transition of minimum pulse width  $t_{\text{KSPW}}$ . When such a transition is detected, the  $\overline{\text{PWR}}$  line will be pulled low, as it is for a wake up condition. Also at this time, the Kickstart Flag KSF will be set, indicating that a kickstart condition has occurred. The  $\overline{\text{KS}}$  input pin is always enabled and must not be allowed to float.

The timing associated with both the wake up and kickstarting sequence is illustrated in the Wake Up/Kickstart Timing Diagram, Figure 3. The timing associated with these functions is divided into 5 intervals, labeled 1-5 on the diagram.

The occurrence of either a kickstart or wake up condition will cause the  $\overline{\text{PWR}}$  pin to be driven low, as described above. During interval 1, if the supply voltage on the DS1501/DS1511  $V_{\text{CC}}$  pin rises above  $V_{\text{SO}}$  before the power on timeout period ( $t_{\text{POTO}}$ ) expires, then  $\overline{\text{PWR}}$  will remain at the active low level. If  $V_{\text{CC}}$  does not rise above the  $V_{\text{SO}}$  in this time, then the  $\overline{\text{PWR}}$  output pin will be turned off and will return to its high impedance level. In this event, the  $\overline{\text{IRQ}}$  pin will also remain tri-stated. The interrupt flag bit (either TDF or KSF) associated with the attempted power on sequence will remain set until cleared by software during a subsequent system power on.

If  $V_{\text{CC}}$  is applied within the time-out period, then the system power on sequence will continue as shown in intervals 2-5 in the timing diagram. During interval 2,  $\overline{\text{PWR}}$  will remain active and  $\overline{\text{IRQ}}$  will be driven to its active low level, indicating that either TDF or KSF was set in initiating the power on. In the diagram  $\overline{\text{KS}}$  is assumed to be pulled up to the  $V_{\text{BAUX}}$  supply. Also at this time, the PAB bit will be automatically cleared to "0" in response to a successful power on. The  $\overline{\text{PWR}}$  line will remain active as long as the PAB remains cleared to "0".

At the beginning of interval 3, the system processor has begun code execution and clears the interrupt condition of TDF and/or KSF by writing zeroes to both of these control bits. As long as no other interrupt within the DS1501/DS1511 is pending, the  $\overline{\text{IRQ}}$  line will be taken inactive once these bits are reset, and execution of the application software may proceed. During this time, both the wakeup and kickstart functions may be used to generate status and interrupts. TDF will be set in response to a day/date, hours, minutes, and seconds match condition. KSF will be set in response to a low going transition on  $\overline{\text{KS}}$ . If the associated interrupt enable bit is set (TIE and/or KIE) then the  $\overline{\text{IRQ}}$  line will be driven low in response to enabled event. In addition, the other possible interrupt sources within the DS1501/DS1511 may cause  $\overline{\text{IRQ}}$  to be driven low. While system power is applied, the on chip logic will always attempt to drive the  $\overline{\text{PWR}}$  pin active in response to the enabled kickstart or wake up condition. This is true even if  $\overline{\text{PWR}}$  was previously inactive as the result of power being applied by some means other than wake up or kickstart.

The system may be powered down under software control by setting the PAB bit to a “1”. The PAB bit can only be set to a “1” after the TDF and KSF flags have been cleared to a “0”. Setting PAB to a “1” causes the open-drain  $\overline{\text{PWR}}$  pin to be placed in a high impedance state, as shown at the beginning of interval 4 in the timing diagram. As  $V_{CC}$  voltage decays, the  $\overline{\text{IRQ}}$  output pin will be placed in a high impedance state when  $V_{CC}$  goes below  $V_{PF}$ . If the system is to be again powered on in response to a wake up or kickstart, then both the TDF and KSF flags should be cleared and TPE and/or KIE should be enabled prior to setting the PAB bit.

During interval 5, the system is fully powered down. Battery backup of the clock calendar and nonvolatile RAM is in effect and  $\overline{\text{IRQ}}$  is tri-stated, and monitoring of wake up and kickstart takes place. If  $\text{PRS}="1"$ ,  $\overline{\text{PWR}}$  stays active, otherwise if  $\text{PRS}="0"$ ,  $\overline{\text{PWR}}$  is tri-stated.

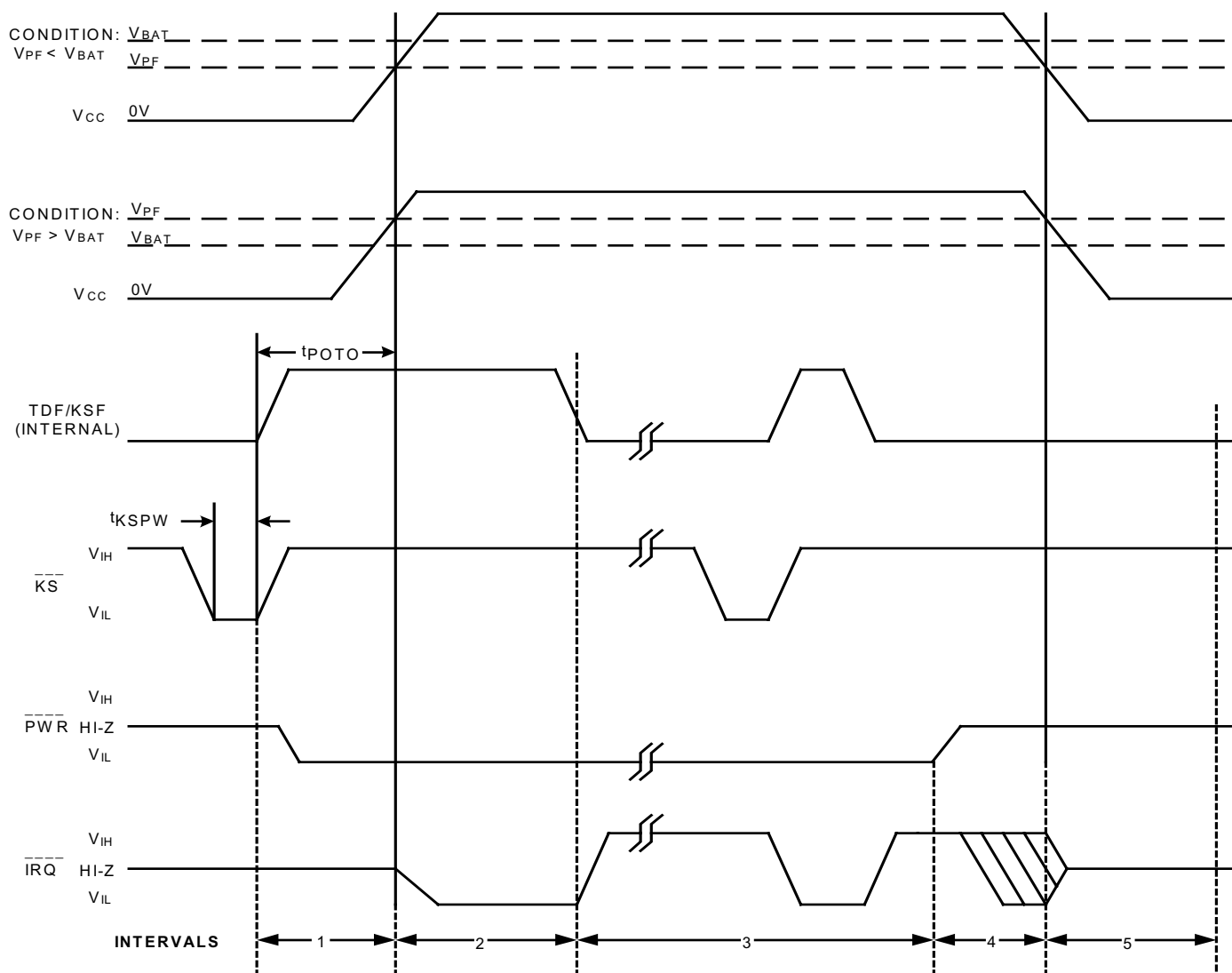
**WAKE-UP/KICKSTART TIMING Figure 3****NOTE:**

Time intervals shown above are referenced in Wake-up/Kickstart section.

**WAKE-UP/KICKSTART TIMING**(T<sub>A</sub> = 5°C)

PARAMETER	SYMBOL	MIN	TYP	MAX	UNITS	NOTES
Kickstart Input Pulse Width	t <sub>KSPW</sub>	2			μs	
Wake-up/Kickstart Power-on Timeout	t <sub>POTO</sub>	2			seconds	5

## SQUARE WAVE OUTPUT

The square wave output is enabled and disabled via the  $\overline{E32K}$  bit. If the square wave is enabled ( $\overline{E32K} = "0"$ ) and the oscillator is running, then a 32.768 kHz square wave will be output on the SQW pin. If the Battery Backup 32 kHz enable bit (BB32) is enabled, and voltage is applied to  $V_{BAUX}$ , then the 32.768 kHz square wave will be output on the SQW pin in the absence of  $V_{CC}$ .

## BATTERY MONITOR

The DS1501/DS1511 constantly monitors the battery voltage of the back-up battery sources ( $V_{BAT}$  and  $V_{BAUX}$ ). The Battery Low Flags BLF1 and BLF2 will be set to a "1" if the battery voltage on  $V_{BAT}$  and  $V_{BAUX}$  are less than 2.5 volts (typical), otherwise BLF1 and BLF2 will be a "0". BLF1 monitors  $V_{BAT}$ , and BLF2 monitors  $V_{BAUX}$ .

## POWER-UP DEFAULT STATES

These bits are set upon power-up:  $\overline{EOSC} = "0"$ ,  $\overline{E32K} = "0"$ ,  $\overline{TIE} = "0"$ ,  $\overline{KIE} = "0"$ ,  $\overline{WDE} = "0"$ , and  $\overline{WDS} = "0"$ .

## 256 X 8 EXTENDED RAM

The DS1501/DS1511 provides 256 x 8 of on-chip SRAM which is controlled as nonvolatile storage sustained from a lithium battery. On power-up, the RAM is taken out of write protect status by an internal signal.

Access to the SRAM is controlled by two on-chip latch registers. One register is used to hold the SRAM address, and the other is used to hold read/write data. The SRAM address space is from 00h to FFh. The 8-bit address of the RAM location to be accessed must be loaded into the extended RAM address register located at 10h. Data in the addressed location may be read by performing a read operation from location 13h, or written to by performing a write operation to location 13h. Data in any addressed location may be read or written repeatedly with changing the address in location 10h.

To read or write consecutive extended RAM locations, a burst mode feature can be enabled to increment the extended RAM address. To enable the burst mode feature, set the BME bit to a 1. With burst mode enabled, write the extended RAM starting address location to register 10h. Then read or write the extended RAM data from/to register 13h. The extended RAM address locations are automatically incremented on the rising edge of  $\overline{OE}$ ,  $\overline{WE}$ , or  $\overline{CS}$  only when register 13h is being accessed. Refer to the Burst Mode Timing Waveform (Figure 7).



**ABSOLUTE MAXIMUM RATINGS\***

Voltage on Any Pin Relative to Ground	-0.5V to +6.0V
Operating Temperature, Commercial Range	0°C to 70°C
Operating Temperature, Industrial Range	-40°C to +85°C
Storage Temperature, DS1501	-55°C to +125°C
Storage Temperature, DS1511	-40°C to +70°C
Soldering Temperature	260°C for 10 seconds (DIP Package) (See Note 7) See IPC/JEDEC Standard J-STD-020A for Surface Mount Devices

\* This is a stress rating only and functional operation of the device at these or any other conditions above those indicated in the operation sections of this specification is not implied. Exposure to absolute maximum rating conditions for extended periods of time may affect reliability.

**OPERATING RANGE**

Range	Temperature	V <sub>CC</sub>
Commercial	0°C to +70°C	3.3V ± 10% or 5V ± 10%
Industrial	-40°C to +85°C	3.3V ± 10% or 5V ± 10%

**RECOMMENDED DC OPERATING CONDITIONS** (Over the Operating Range)

PARAMETER	SYMBOL	MIN	TYP	MAX	UNITS	NOTES
Power Supply Voltage 5V Operation	V <sub>CC</sub>	4.5	5.0	5.5	V	1
Power Supply Voltage 3.3V Operation	V <sub>CC</sub>	3.0	3.3	3.6	V	1
Logic 1 Voltage All Inputs V <sub>CC</sub> = 5V ±10% V <sub>CC</sub> = 3.3V ±10%	V <sub>IH</sub>	2.2		V <sub>CC</sub> +0.3	V	1
	V <sub>IH</sub>	2.0		V <sub>CC</sub> +0.3	V	1
Logic 0 Voltage All Inputs V <sub>CC</sub> = 5V ±10% V <sub>CC</sub> = 3.3V ±10%	V <sub>IL</sub>	-0.3		0.8	V	1
	V <sub>IL</sub>	-0.3		0.6	V	1
Battery Voltage	V <sub>BAT</sub>	2.5		3.7	V	1
Auxiliary Battery Voltage 5V Operation	V <sub>BAUX</sub>	2.5		5.3	V	1
Auxiliary Battery Voltage 3V Operation	V <sub>BAUX</sub>	2.5		3.7	V	1

**DC ELECTRICAL CHARACTERISTICS**(Over the Operating Range;  $V_{CC} = 5.0V \pm 10\%$ )

PARAMETER	SYMBOL	MIN	TYP	MAX	UNITS	NOTES
Active Supply Current	$I_{CC}$			15	mA	2
TTL Standby Current( $\overline{CE} = V_{IH}$ )	$I_{CC1}$			5	mA	2
CMOS Standby Current ( $\overline{CE} \geq V_{CC} - 0.2V$ )	$I_{CC2}$			5	mA	2
Battery Current, Oscillator On	$I_{BAT1}$			1.0	$\mu A$	
Battery Current, Oscillator Off	$I_{BAT2}$			0.1	$\mu A$	
Input Leakage Current (any input)	$I_{IL}$	-1		+1	$\mu A$	
Output Leakage Current (any output)	$I_{OL}$	-1		+1	$\mu A$	
Output Logic 1 Voltage ( $I_{OUT} = -1.0$ mA)	$V_{OH}$	2.4			V	1
Output Logic 0 Voltage $I_{OUT} = 2.1$ mA, $\overline{DQ0-7}$ Outputs	$V_{OL1}$			0.4	V	1
$I_{OUT} = 7.0$ mA, $\overline{IRQ}$ , $\overline{PWR}$ , and $\overline{RST}$ Outputs	$V_{OL2}$			0.4	V	1, 3
Power-fail Voltage	$V_{PF}$	4.25		4.50	V	1
Battery Switch-over Voltage	$V_{SO}$		$V_{BAT}$ , $V_{BAUX}$ or $V_{PF}$		V	1, 4

**DC ELECTRICAL CHARACTERISTICS**(Over the Operating Range;  $V_{CC} = 3.3V \pm 10\%$ )

PARAMETER	SYMBOL	MIN	TYP	MAX	UNITS	NOTES
Active Supply Current	$I_{CC}$			10	mA	2
TTL Standby Current( $\overline{CE} = V_{IH}$ )	$I_{CC1}$			4	mA	2
CMOS Standby Current ( $\overline{CE} \geq V_{CC} - 0.2V$ )	$I_{CC2}$			4	mA	2
Battery Current, Oscillator On	$I_{BAT1}$			1.0	$\mu A$	
Battery Current, Oscillator Off	$I_{BAT2}$			0.1	$\mu A$	
Input Leakage Current (any input)	$I_{IL}$	-1		+1	$\mu A$	
Output Leakage Current (any output)	$I_{OL}$	-1		+1	$\mu A$	
Output Logic 1 Voltage ( $I_{OUT} = -1.0$ mA)	$V_{OH}$	2.4			V	1
Output Logic 0 Voltage $I_{OUT} = -2.1$ mA, $\overline{DQ0-7}$ Outputs	$V_{OL1}$			0.4	V	1
$I_{OUT} = 7.0$ mA, $\overline{IRQ}$ , $\overline{PWR}$ , and $\overline{RST}$ Outputs	$V_{OL2}$			0.4	V	1, 3
Power-fail Voltage	$V_{PF}$	2.80		2.97	V	1
Battery Switch-over Voltage	$V_{SO}$		$V_{BAT}$ , $V_{BAUX}$ , or $V_{PF}$		V	1, 4

**AC OPERATING CHARACTERISTICS**(Over the Operating Range;  $V_{CC} = 5.0V \pm 10\%$ )

PARAMETER	SYMBOL	MIN	TYPE	MAX	UNITS	NOTES
Read Cycle Time	$t_{RC}$	70			ns	
Address Access Time	$t_{AA}$			70	ns	
$\overline{CE}$ to DQ Low-Z	$t_{CEL}$	5			ns	
$\overline{CE}$ Access Time	$t_{CEA}$			70	ns	
$\overline{CE}$ Data Off Time	$t_{CEZ}$			25	ns	
$\overline{OE}$ to DQ Low-Z	$t_{OEL}$	5			ns	
$\overline{OE}$ Access Time	$t_{OEA}$			35	ns	
$\overline{OE}$ Data Off Time	$t_{OEZ}$			25	ns	
Output Hold from Address	$t_{OH}$	5			ns	
Write Cycle Time	$t_{WC}$	70			ns	
Address Setup Time	$t_{AS}$	0			ns	
$\overline{WE}$ Pulse Width	$t_{WEW}$	50			ns	
$\overline{CE}$ Pulse Width	$t_{CEW}$	55			ns	
Data Setup Time	$t_{DS}$	30			ns	
Data Hold Time	$t_{DS}$	30			ns	
Address Hold Time	$t_{AH}$	0			ns	
$\overline{WE}$ Data Off Time	$t_{WEZ}$			25	ns	
Write Recovery Time	$t_{WR}$	5			ns	

**AC OPERATING CHARACTERISTICS**(Over the Operating Range;  $V_{CC} = 3.3V \pm 10\%$ )

PARAMETER	SYMBOL	MIN	TYPE	MAX	UNITS	NOTES
Read Cycle Time	$t_{RC}$	120			ns	
Address Access Time	$t_{AA}$			120	ns	
$\overline{CE}$ to DQ Low-Z	$t_{CEL}$	5			ns	
$\overline{CE}$ Access Time	$t_{CEA}$			120	ns	
$\overline{CE}$ Data Off Time	$t_{CEZ}$			40	ns	
$\overline{OE}$ to DQ Low-Z	$t_{OEL}$	5			ns	
$\overline{OE}$ Access Time	$t_{OEA}$			100	ns	
$\overline{OE}$ Data Off Time	$t_{OEZ}$			35	ns	
Output Hold from Address	$t_{OH}$	5			ns	
Write Cycle Time	$t_{WC}$	120			ns	
Address Setup Time	$t_{AS}$	0			ns	
$\overline{WE}$ Pulse Width	$t_{WEW}$	100			ns	
$\overline{CE}$ Pulse Width	$t_{CEW}$	110			ns	
Data Setup Time	$t_{DS}$	80			ns	
Data Hold Time	$t_{DH}$	0			ns	
Address Hold Time	$t_{AH}$	0			ns	
$\overline{WE}$ Data Off Time	$t_{WEZ}$			40	ns	
Write Recovery Time	$t_{WR}$	10			ns	

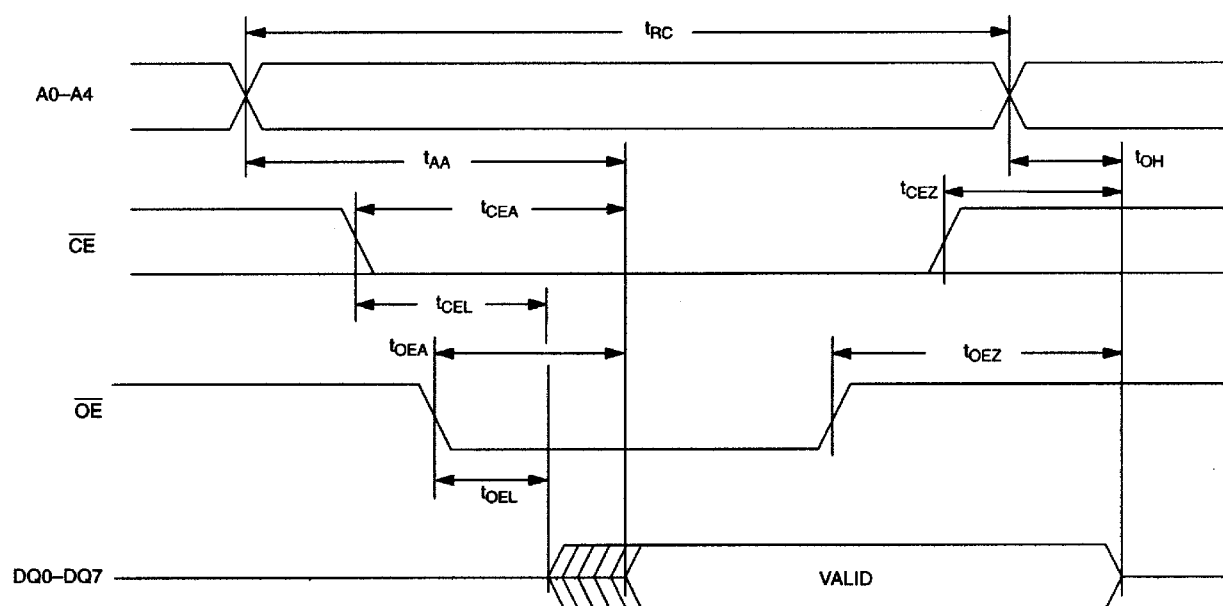
**READ CYCLE TIMING Figure 4**

**WRITE CYCLE TIMING, WRITE ENABLE CONTROLLED Figure 5**

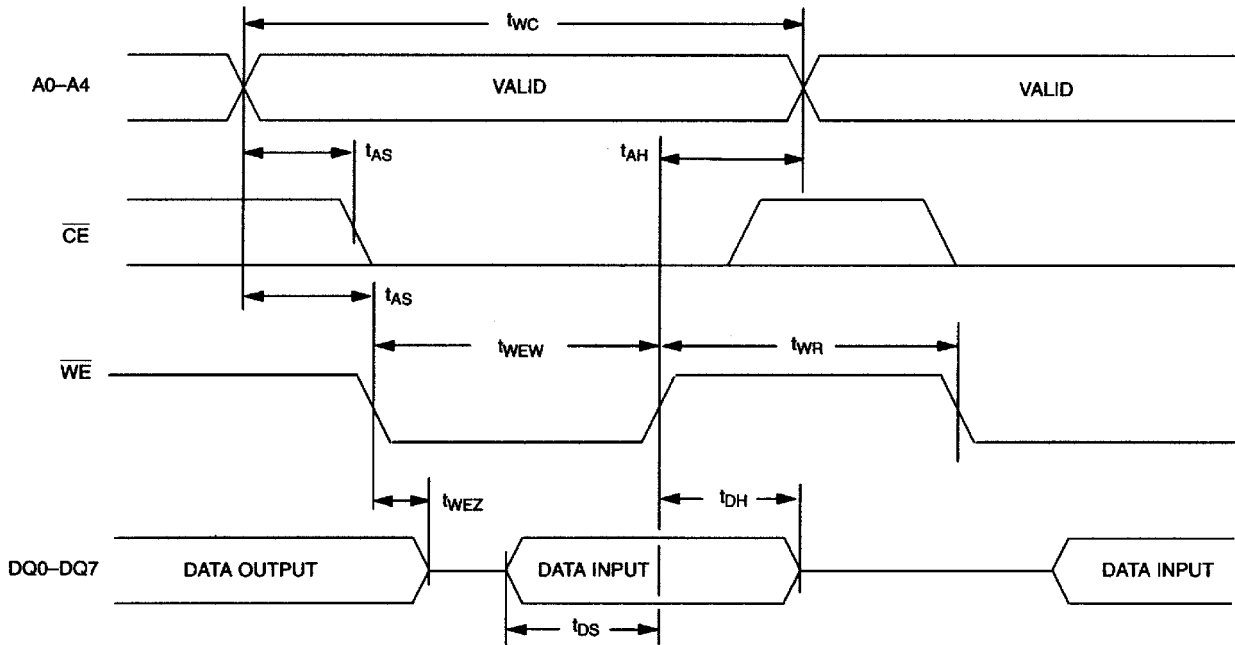

**WRITE CYCLE TIMING, CHIP ENABLE CONTROLLED Figure 6**

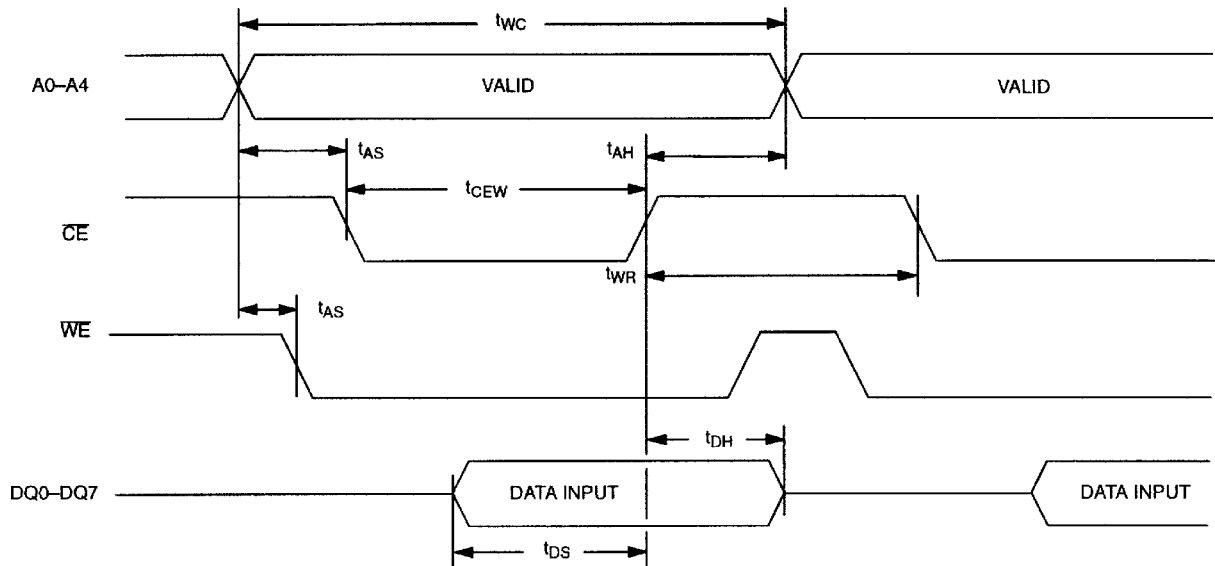

**BURST MODE TIMING CHARACTERISTICS** ( $V_{CC}=5.0V\pm 10\%$ )

PARAMETER	SYMBOL	MIN	TYP	MAX	UNITS	NOTES
Pulse Width $\overline{OE}$ , $\overline{WE}$ , or $\overline{CE}$ High	$PW_{HIGH}$	x			ns	
Pulse Width $\overline{OE}$ , $\overline{WE}$ , or $\overline{CE}$ Low	$PW_{LOW}$	x			ns	

**BURST MODE TIMING CHARACTERISTICS** ( $V_{CC}=3.3V\pm 10\%$ )

PARAMETER	SYMBOL	MIN	TYP	MAX	UNITS	NOTES
Pulse Width $\overline{OE}$ , $\overline{WE}$ , or $\overline{CE}$ High	$PW_{HIGH}$	x			ns	
Pulse Width $\overline{OE}$ , $\overline{WE}$ , or $\overline{CE}$ Low	$PW_{LOW}$	x			ns	

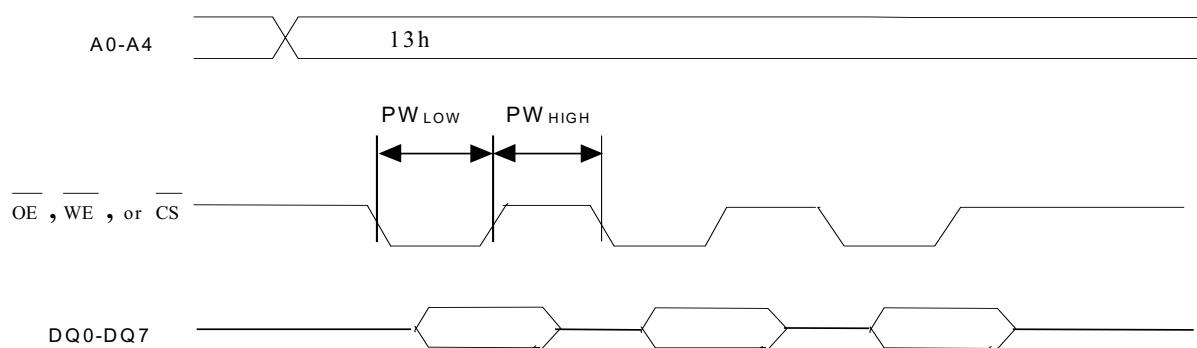
**BURST MODE TIMING WAVEFORM** Figure 7

**POWER UP/DOWN CHARACTERISTICS**

PARAMETER	SYMBOL	MIN	TYP	MAX	UNITS	NOTES
$\overline{CE}$ or $\overline{WE}$ at $V_{IH}$ Before Power Fail	$T_{PD}$	0			$\mu s$	
$V_{CC}$ Fall Time: $V_{PF(MAX)}$ to $V_{PF(MIN)}$	$t_F$	300			$\mu s$	
$V_{CC}$ Fall Time: $V_{PF(MIN)}$ to $V_{SO}$	$T_{FB}$	10			$\mu s$	
$V_{CC}$ Rise Time: $V_{PF(MIN)}$ to $V_{PF(MAX)}$	$t_R$	0			$\mu s$	
$V_{PF}$ to $\overline{RST}$ High	$t_{REC}$	40		200	ms	

(T<sub>A</sub> = 25°C)

PARAMETER	SYMBOL	MIN	TYP	MAX	UNITS	NOTES
Expected Data Retention Time(Oscillator On)	$t_{DR}$	10			years	6

**CAPACITANCE**(T<sub>A</sub> = 25°C)

PARAMETER	SYMBOL	MIN	TYP	MAX	UNITS	NOTES
Capacitance on all input pins	$C_{IN}$			10	pF	
Capacitance on $\overline{IRQ}$ , $\overline{PWR}$ , $\overline{RST}$ , and DQ pins	$C_{IO}$			10	pF	

**AC TEST CONDITIONS**

Output Load: 100 pF + 1TTL Gate  
 Input Pulse Levels: 0.0 to 3.0V for 5V operation  
 0.0 to 2.7V for 3.3V operation

Timing Measurement Reference Levels:

Input: 1.5V

Output: 1.5V

Input Pulse Rise and Fall Times: 5 ns



**POWER-UP/DOWN WAVEFORM TIMING 5-VOLT DEVICE Figure 8**

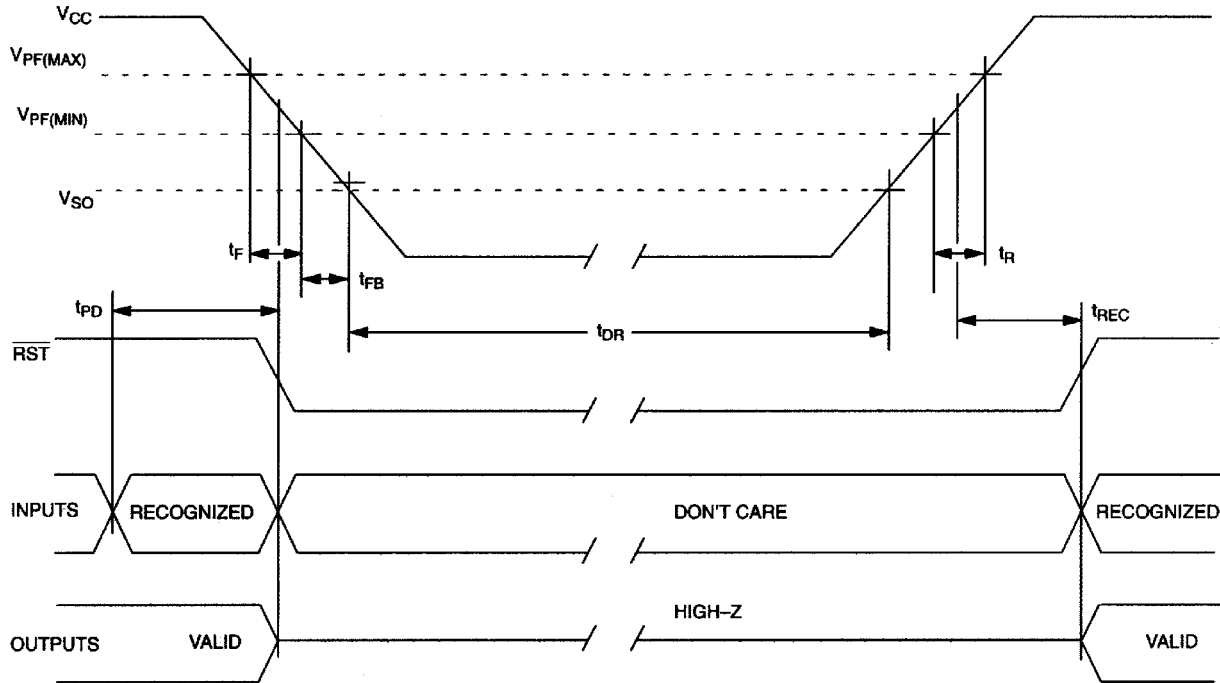

**POWER-UP/DOWN WAVEFORM TIMING 3.3-VOLT DEVICE Figure 9**

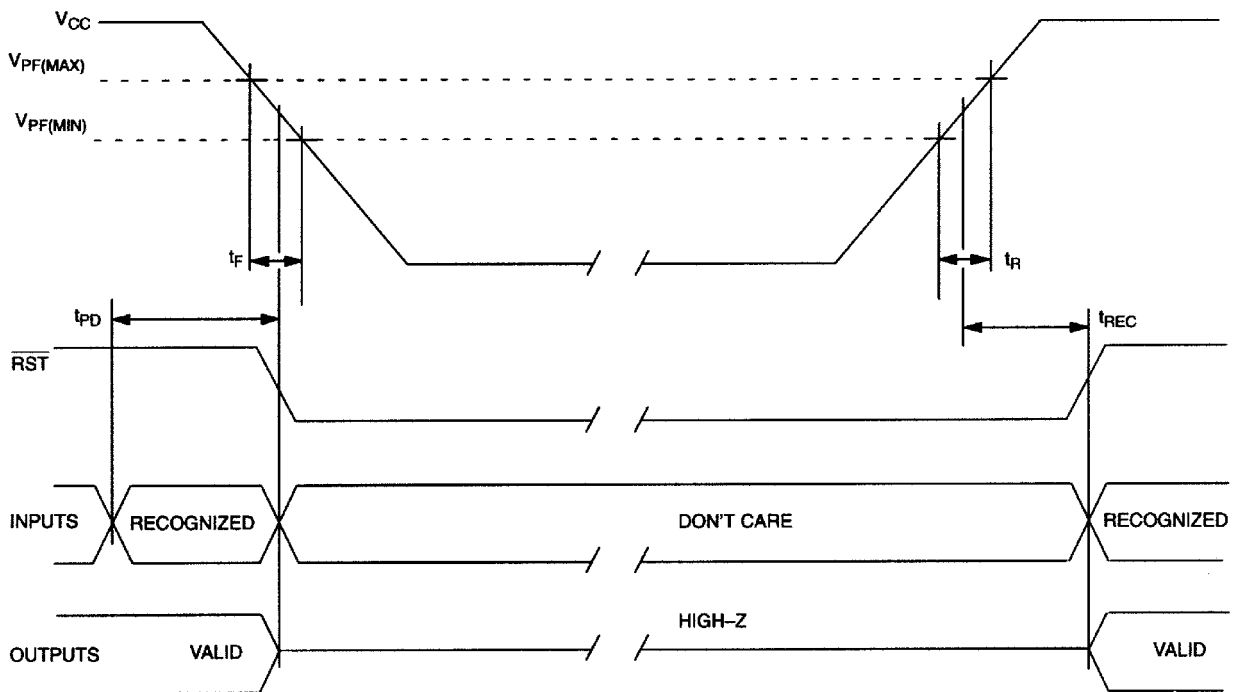

**NOTE**

1. Voltage referenced to ground.
2. Outputs are open.
3. The  $\overline{\text{IRQ}}$ ,  $\overline{\text{PWR}}$ , and  $\overline{\text{RST}}$  outputs are open drain.
4. If  $V_{\text{PF}}$  is less than  $V_{\text{BAT}}$  and  $V_{\text{BAUX}}$ , the device power is switched from  $V_{\text{CC}}$  to the greater of  $V_{\text{BAT}}$  and  $V_{\text{BAUX}}$  when  $V_{\text{CC}}$  drops below  $V_{\text{PF}}$ . If  $V_{\text{PF}}$  is greater than  $V_{\text{BAT}}$  and  $V_{\text{BAUX}}$ , the device power is switched from  $V_{\text{CC}}$  to the larger of  $V_{\text{BAT}}$  and  $V_{\text{BAUX}}$  when  $V_{\text{CC}}$  drops below the larger of  $V_{\text{BAT}}$  and  $V_{\text{BAUX}}$ .
5. The wake-up timeout is generated only when the oscillator is enabled.
6.  $t_{\text{DR}}$  is the amount of time that the internal battery can power the internal oscillator and internal registers of the DS1511.
7. Real-Time Clock Modules can be successfully processed through conventional wave-soldering techniques as long as temperature exposure to the lithium energy source contained within does not exceed +85°C. Post-solder cleaning with water washing techniques is acceptable, provided that ultrasonic vibration is not used.

## DS1501 28-PIN

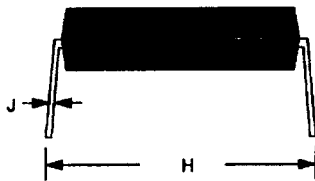
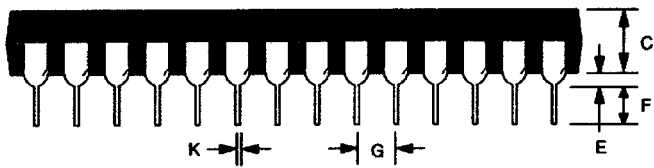
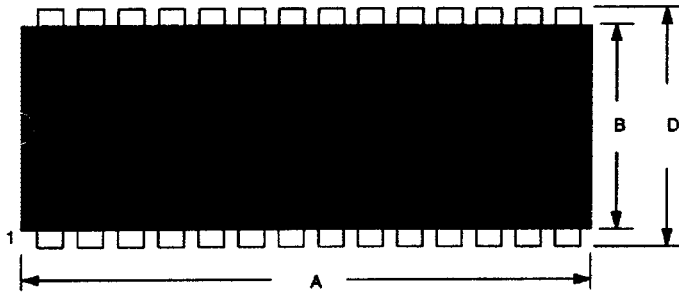

PKG DIM	28-PIN	
	MIN	MAX
A IN.	1.445	1.470
MM	36.70	37.34
B IN.	0.530	0.550
MM	13.46	13.97
C IN.	0.140	0.160
MM	3.56	4.06
D IN.	0.600	0.625
MM	15.24	15.88
E IN.	0.015	0.040
MM	0.38	1.02
F IN.	0.120	0.145
MM	3.05	3.68
G IN.	0.090	0.110
MM	2.29	2.79
H IN.	0.625	0.675
MM	15.88	17.15
J IN.	0.008	0.012
MM	0.20	0.30
K IN.	0.015	0.022
MM	0.38	0.56

## DS1501S 28-PIN SOIC

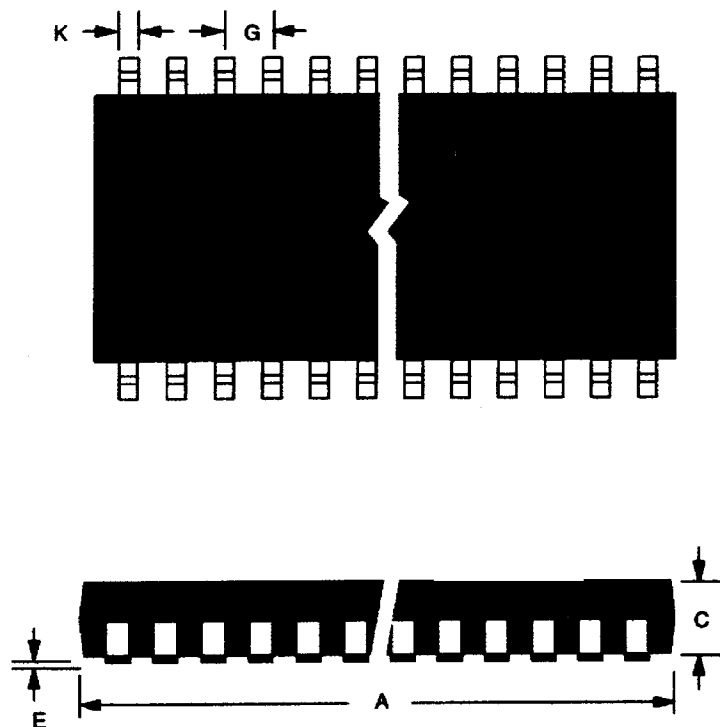

PKG	28-PIN	
DIM	MIN	MAX
A IN.	0.706	0.728
MM	17.93	18.49
B IN.	0.338	0.350
MM	8.58	8.89
C IN.	0.086	0.110
MM	2.18	2.79
D IN.	0.020	0.050
MM	0.58	1.27
E IN.	0.002	0.014
MM	0.05	0.36
F IN.	0.090	0.124
MM	2.29	3.15
G IN.	0.050	BSC
MM	1.27	
H IN.	0.460	0.480
MM	11.68	12.19
J IN.	0.006	0.013
MM	0.15	0.33
K IN.	0.014	0.020
MM	0.36	0.51

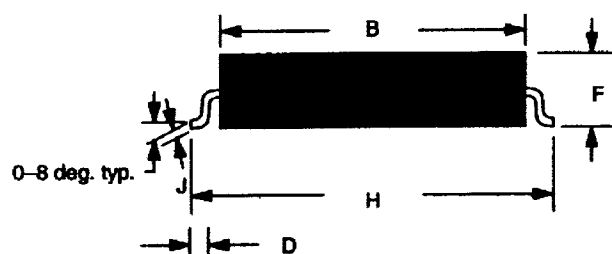

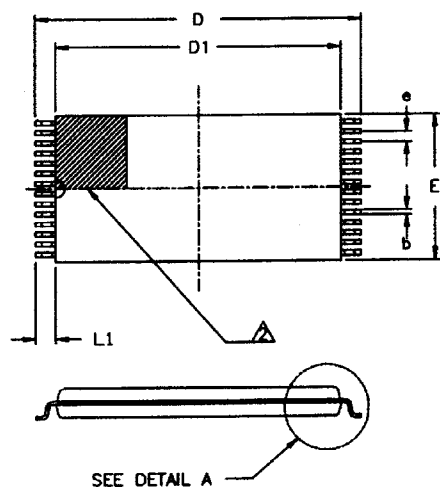
**DS1501E 28-PIN TSOP**

## NOTES:

1. ALL DIMENSIONS ARE IN MILLIMETERS

2. DETAILS OF PIN 1 IDENTIFIER ARE OPTIONAL BUT ONE HALF OF ITS AREA MUST BE LOCATED WITHIN THE ZONE INDICATED

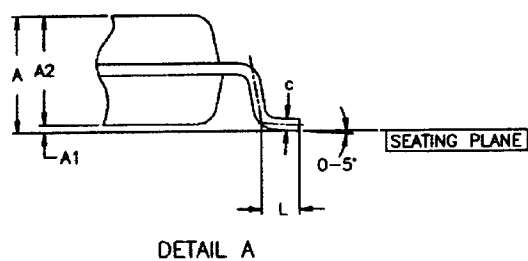

PKG DIM	28-PIN	
	MIN	MAX
A	-	1.20
A1	0.05	-
A2	0.91	1.02
b	0.18	0.27
c	0.15	0.20
D	13.20	13.60
D1	11.70	11.90
E	7.90	8.10
e	0.55 BSC	
L	0.30	0.70
l	0.80 BSC	

**DS1511**

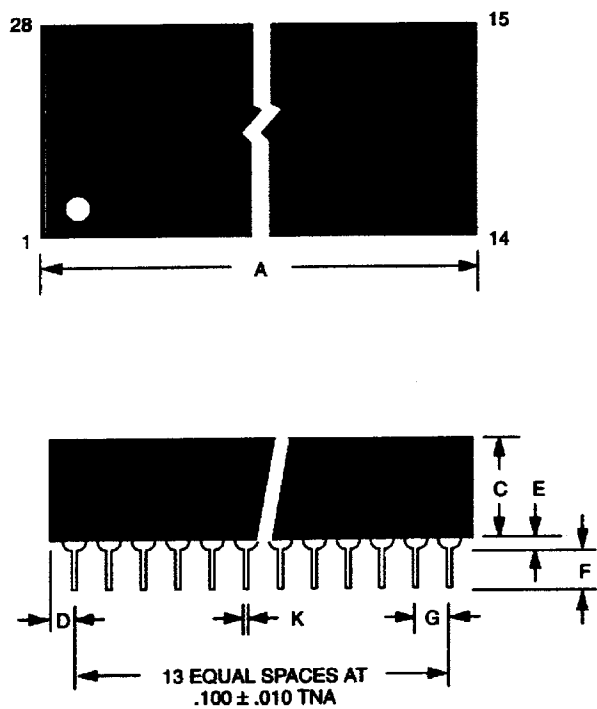

PKG DIM	28-PIN	
	MIN	MAX
A IN.	1.520	1.540
MM	38.61	39.12
B IN.	0.695	0.720
MM	17.65	18.29
C IN.	0.350	0.375
MM	8.89	9.52
D IN.	0.100	0.130
MM	2.54	3.30
E IN.	0.015	0.030
MM	0.38	0.76
F IN.	0.110	0.140
MM	2.79	3.56
G IN.	0.090	0.110
MM	2.29	2.79
H IN.	0.590	0.630
MM	14.99	16.00
J IN.	0.008	0.012
MM	0.20	0.30
K IN.	0.015	0.021
MM	0.38	0.53

NOTE: PINS 2, 3, 21, AND 25 ARE MISSING BY DESIGN.