



Plug and Play Wireless CPU®

Fastrack Supreme User Guide

Revision: 003
Date: November 2007

wavecom®
Make it wireless

Operating Systems | Plug-Ins | Integrated Development Environments | **Wireless CPUs** | Services

Plug and Play Wireless CPU[®]

Fastrack Supreme User Guide

Reference: WA_DEV_Fastrk_UGD_001

Revision: 003

Date: November 5, 2007



Supports Open AT[®] embedded ANSI C applications

Document History

Revision	Date	List of revisions	
001	June 5, 2007	First Issue	
002	September 6, 2007	Update	
003	November 5, 2007	Update	

Overview

The Fastrack Supreme 10 and Fastrack Supreme 20 are discrete, rugged cellular Plug & Play Wireless CPU® offering state-of-the-art GSM/GPRS (and EGPRS for Fastrack Supreme 20) connectivity for machine to machine applications.

Proven for reliable, stable performance on wireless networks worldwide, Wavecom's latest generation of Fastrack Supreme continues to deliver rapid time to market and painless integration.

Having comparable size with the previous M1306B generation, and updated with new features, the Fastrack Supreme offers an Internal Expansion Socket (IES) interface accessible for customer use. Expanding application features is easy without voiding the warrantee of the Fastrack Supreme by simply plugging in of an Internal Expansion Socket Module (IESM) board.

Fully certified, the quad band 850/900/1800/1900 MHz Fastrack Supreme 10 offers GPRS Class 10 capability and Fastrack Supreme 20 offers GPRS/EGPRS Class 10 capability. Both support a powerful open software platform (Open AT®). Open AT® is the world's most comprehensive cellular development environment, which allows embedded standard ANSI C applications to be natively executed directly on the Wireless CPU®.

Fastrack Supreme is controlled by firmware through a set of AT commands.

This document describes the Fastrack Supreme and gives information on the following topics:

- general presentation,
- functional description,
- basic services available,
- technical characteristics,
- installing and using the Fastrack Supreme,
- user-level troubleshooting.
- recommended accessories to be used with the product.

Note:

This document covers the Fastrack Supreme Plug & Play alone and does not include

- The programmable capabilities provided via the use of Open AT® Software Suites.
- The development guide for IESM for expanding the application feature through the IES interface.

For detailed, please refer to the documents shown in the "Reference Documents" section.

RoHS Directive

The Fastrack Supreme is now compliant with RoHS Directive 2002/95/EC, which sets limits for the use of certain restricted hazardous substances. This directive states that "from 1st July 2006, new electrical and electronic equipment put on the market does not contain lead, mercury, cadmium, hexavalent chromium, polybrominated biphenyls (PBB), and polybrominated diphenyl ethers (PBDE)".

Plug & Plays which are compliant with this directive are identified by the RoHS logo on their label.



Disposing of the product

This electronic product is subject to the EU Directive 2002/96/EC for Waste Electrical and Electronic Equipment (WEEE). As such, this product must not be disposed off at a municipal waste collection point. Please refer to local regulations for directions on how to dispose off this product in an environmental friendly manner.



Cautions

Information furnished herein by WAVECOM is accurate and reliable. However, no responsibility is assumed for its use. Please read carefully the safety recommendations given in Section 9 for an application based on Fastrack Supreme Plug & Play.

Trademarks

®, WAVECOM®, Wireless CPU®, Open AT® and certain other trademarks and logos appearing on this document, are filed or registered trademarks of Wavecom S.A. in France or in other countries. All other company and/or product names mentioned may be filed or registered trademarks of their respective owners.

Copyright

This manual is copyrighted by WAVECOM with all rights reserved. No part of this manual may be reproduced in any form without the prior written permission of WAVECOM. No patent liability is assumed with respect to the use of their respective owners.

Web Site Support

General information about Wavecom and its range of products:	www.wavecom.com
Specific support is available for the Fastrack Supreme Plug & Play Wireless CPU®:	www.wavecom.com/fastracksupreme
Open AT® Introduction:	www.wavecom.com/OpenAT
Developer community for software and hardware:	www.wavecom.com/forum

Contents

DOCUMENT HISTORY	2
OVERVIEW	3
CAUTIONS	5
TRADEMARKS	5
COPYRIGHT	5
WEB SITE SUPPORT	6
CONTENTS	7
LIST OF FIGURES	11
LIST OF TABLES.....	12
1 REFERENCES.....	14
1.1 Reference Documents.....	14
1.1.1 Open AT® Software Documentation	14
1.1.2 AT Software Documentation.....	14
1.1.3 Delta between M1306B Documents	14
1.1.4 IESM Related Documents	14
1.2 Abbreviations	15
2 PACKAGING	18
2.1 Contents.....	18
2.2 Packaging Box.....	19
2.3 Production Labelling.....	20
3 GENERAL PRESENTATION.....	21
3.1 Description	21
3.2 External Connections.....	23
3.2.1 Connectors	23
3.2.1.1 Antenna Connector	23
3.2.1.2 Power Supply Connector.....	23

Fastrack Supreme User Guide

3.2.1.3	Sub HD 15-pin Connector	24
3.2.1.4	IES Connector	26
3.2.2	Power Supply Cable.....	30
4	FEATURES AND SERVICES	31
4.1	Basic Features and Services	31
4.2	Additional NEW Features.....	33
4.2.1	Support Additional GSM850/PCS1900 Bands.....	33
4.2.2	IES Interface for Easy Expansion of Application Features	33
4.2.3	Serial Port Auto Shut Down or Improving Power Consumption	33
4.2.4	Real Time Clock (RTC) for Saving Date and Time	34
4.2.5	SIM Card Lock Feature.....	34
5	USING THE FASTRACK SUPREME PLUG & PLAY.....	35
5.1	Getting Started	35
5.1.1	Mount the Fastrack Supreme.....	35
5.1.2	Insert/extract the SIM card to/from the Fastrack Supreme.....	35
5.1.3	Set up the Fastrack Supreme	37
5.1.4	Check the communication with the Fastrack Supreme.....	38
5.1.5	Reset the Fastrack Supreme.....	39
5.2	Specific Recommendations when Using the Fastrack Supreme on Trucks.....	39
5.2.1	Recommended Power Supply Connection on Trucks	39
5.2.2	Technical Constraints on Trucks	40
5.3	Fastrack Supreme Operational Status	41
5.4	Echo Function Disabled	42
5.5	Verify the Received Signal Strength	43
5.6	Check the Pin Code Status.....	43
5.7	Switch between EU/US Band(s).....	44
5.8	Check the Band(s) Selection	44
5.9	Verify the Fastrack Supreme Network Registration	45
5.10	Main AT Commands for the Plug & Play	46
5.11	Firmware Upgrade Procedure	48
6	TROUBLESHOOTING	49
6.1	No Communication with the Fastrack Supreme through the Serial Link.....	49
6.2	Receiving "ERROR" Message	50
6.3	Receiving "NO CARRIER" Message	50
7	FUNCTIONAL DESCRIPTION.....	53
7.1	Architecture.....	53

7.2	EU and US Bands	54
7.2.1	General Presentation	54
7.2.2	AT COMMAND for Bands Switch	54
7.3	Power Supply	54
7.3.1	General Presentation	54
7.3.2	Protections	54
7.4	RS232 Serial Link.....	55
7.4.1	General Presentation	55
7.4.2	Autobauding Mode	56
7.4.3	Pin Description.....	56
7.4.4	Serial Port Auto shut down Feature	56
7.5	General Purpose Input/Output (GPIO)	57
7.6	BOOT	57
7.7	RESET	58
7.7.1	General Presentation	58
7.7.2	Reset Sequence	58
7.8	Audio.....	59
7.8.1	Microphone Inputs.....	59
7.8.2	Speaker Outputs	60
7.9	Real Time Clock (RTC).....	60
7.10	FLASH LED 61	
8	TECHNICAL CHARACTERISTICS	62
8.1	Mechanical Characteristics	62
8.2	Electrical Characteristics	64
8.2.1	Power Supply	64
8.2.2	Power Consumption	65
8.2.3	Audio Interface	68
8.2.4	General Purpose Input/Output.....	69
8.2.5	SIM Interface	69
8.2.6	RESET Signal	69
8.2.7	RF Characteristics	70
8.2.7.1	Frequency Ranges	70
8.2.7.2	RF Performances.....	71
8.2.7.3	External Antenna	71
8.3	Environmental Characteristics	72
8.4	Conformity.....	75
8.5	Protections	75
8.5.1	Power Supply	75
8.5.2	Overvoltage.....	76
8.5.3	Electrostatic Discharge.....	76
8.5.4	Miscellaneous	76
9	SAFETY RECOMMENDATIONS	77

Fastrack Supreme User Guide

9.1	General Safety	77
9.2	Vehicle Safety	78
9.3	Care and Maintenance	78
9.4	Your Responsibility	79
10	RECOMMENDED ACCESSORIES.....	80
11	ONLINE SUPPORT	82

List of Figures

Figure 1: Complete package contents	18
Figure 2: Packaging box	19
Figure 3: Production Label	20
Figure 4: Fastrack Supreme general description.....	21
Figure 5: Fastrack Supreme holding bridles	22
Figure 6: SMA connector for antenna connection	23
Figure 7: Power supply connector	24
Figure 8: Sub HD 15-pin connector	25
Figure 9: IES connector for feature expansion.....	27
Figure 10: Power supply cable.....	30
Figure 11: SIM card lock feature	34
Figure 12: Fastrack Supreme mounting	35
Figure 13: Procedure for SIM card insertion.....	36
Figure 14: Procedure for SIM card extraction.....	37
Figure 15: Recommended power supply connection on trucks	40
Figure 16: Example of electrical connection which may dramatically damage the Fastrack Supreme.....	41
Figure 17: Functional architecture	53
Figure 18: RS232 Serial Link signals.....	55
Figure 19: Reset sequence diagram	59
Figure 20: Dimensioning diagram.....	63

List of Tables

Table 1: Power supply connector pin description.....	24
Table 2: Sub HD 15-pin connector description.....	25
Table 3: IES Connector Description.....	27
Table 4: Basic features of the Fastrack Supreme.....	31
Table 5: Fastrack Supreme operational status	42
Table 6: Values of received signal strength	43
Table 7: AT+CPIN Responses	43
Table 8: AT+WMBS Band Selection	44
Table 9: AT+WMBS Responses.....	44
Table 10: Values of network registration.....	45
Table 11: Main usual AT commands for the Plug & Play	46
Table 12: Solutions for no connection with Fastrack Supreme through serial link.....	49
Table 13: Solutions for "NO CARRIER" message	51
Table 14: Interpretation of extended error code	52
Table 15: Mechanical characteristics	62
Table 16: Electrical characteristics	64
Table 17: Effects of power supply defect	64
Table 18: Power consumption in connected modes (1*).....	65
Table 19: Power consumption in non-connected modes(1*).....	66
Table 20: Audio parameters characteristics	68
Table 21: Microphone inputs internal audio filter characteristics	68
Table 22: Recommended characteristics for the microphone:	68
Table 23: Recommended characteristics for the speaker:	69
Table 24: Operating conditions.....	69
Table 25: SIM card characteristics.....	69
Table 26: Electrical characteristics	69
Table 27: Operating conditions.....	70
Table 28: Frequency ranges.....	70
Table 29: Receiver and transmitter RF performances	71
Table 30: External antenna characteristics.....	71
Table 31: Ranges of temperature.....	72

Fastrack Supreme User Guide

Table 32: Environmental standard constraints.....	73
Table 33: List of recommended accessories.....	80
Table 34: Fastrack Supreme Family	81

1 References

1.1 Reference Documents

For more details, several reference documents may be consulted. The Wavecom reference documents are provided in the Wavecom documents package contrary to the general reference documents, which are not Wavecom owned.

1.1.1 Open AT® Software Documentation

- [1] Getting started with Open AT® SDK v4.22 (Ref.WM_DEV_OAT_UGD_048)
- [2] Tutorial for Open AT® IDE V1.04 (Ref. WM_DEV_OAT_UGD_044)
- [3] Tools Manual for Open AT® IDE V1.04 (Ref. WM_DEV_OAT_UGD_045)
- [4] Basic Development Guide for Open AT®V4.21 (Ref. WM_DEV_OAT_UGD_050)
- [5] ADL User Guide for Open AT®V4.21 (Ref. WM_DEV_OAT_UGD_051)
- [6] Open AT® v4.22 Official Release Note (Ref. WM_DEV_OAT_DVD_338)

1.1.2 AT Software Documentation

- [7] AT commands interface Guide for FW v6.63 (Ref. WM_DEV_OAT_UGD_049)
- [8] Open AT® Firmware v6.63 Customer Release Note (Ref.WM_PGM_OAT_CRN_001)

1.1.3 Delta between M1306B Documents

- [9] Delta between M1306B and Fastrack Supreme (Ref. WA_DEV_Fastrk_UGD_004)

1.1.4 IESM Related Documents

- [10] IESM Product Technical Specification (Ref. WA_DEV_Fastrk_PTS_001)
- [11] IESM-GPS+USB User Guide (Ref. WA_DEV_Fastrk_UGD_002)
- [12] IESM-GPS+USB Installation Guide (Ref. WA_DEV_Fastrk_UGD_003)
- [13] IESM-IO+USB Installation Guide (Ref. WA_DEV_Fastrk_UGD_005)
- [14] IESM-IO+USB User Guide (Ref. WA_DEV_Fastrk_UGD_006)
- [15] IESM-IO+USB+GPS Installation Guide (Ref. WA_DEV_Fastrk_UGD_007)
- [16] IESM-IO+USB+GPS User Guide (Ref. WA_DEV_Fastrk_UGD_008)

Note:

New versions of software may be available. Wavecom recommends customers to check the web site for the latest documentation.

1.2 Abbreviations

Abbreviation	Definition
AC	Alternating Current
ACM	Accumulated Call Meter
AMR	Adaptive Multi-Rate
AT	ATtention (prefix for Wireless CPU® commands)
CLK	CLock
CMOS	Complementary Metal Oxide Semiconductor
CS	Coding Scheme
CTS	Clear To Send
dB	Decibel
dBc	Decibel relative to the Carrier power
dB _i	Decibel relative to an Isotropic radiator
dB _m	Decibel relative to one milliwatt
DC	Direct Current
DCD	Data Carrier Detect
DCE	Data Communication Equipment
DCS	Digital Cellular System
DSR	Data Set Ready
DTE	Data Terminal Equipment
DTMF	Dual Tone Multi-Frequency
DTR	Data Terminal Ready
EEPROM	Electrically Erasable Programmable Read-Only Memory
EFR	Enhanced Full Rate
E-GSM	Extended GSM
EMC	ElectroMagnetic Compatibility
EMI	ElectroMagnetic Interference
ESD	ElectroStatic Discharges
ETSI	European Telecommunications Standards Institute
FIT	Series of connectors (micro-FIT)
FR	Full Rate
FTA	Full Type Approval
GCF	Global Certification Forum

Abbreviation	Definition
GND	GrouND
GPIO	General Purpose Input Output
GPRS	General Packet Radio Service
GSM	Global System for Mobile communications
HR	Half Rate
I	Input
IEC	International Electrotechnical Commission
IES	Internal Expansion Socket
IESM	Internal Expansion Socket Module
IMEI	International Mobile Equipment Identification
I/O	Input / Output
LED	Light Emitting Diode
MAX	MAXimum
ME	Mobile Equipment
MIC	MICROphone
Micro-Fit	Family of connectors from Molex
MIN	MINimum
MNP	Microcom Networking Protocol
MO	Mobile Originated
MS	Mobile Station
MT	Mobile Terminated
NOM	NOMinal
O	Output
Pa	Pascal (for speaker sound pressure measurements)
PBCCH	Packet Broadcast Control CHannel
PC	Personal Computer
PCL	Power Control Level
PDP	Packet Data Protocol
PIN	Personal Identity Number
PLMN	Public Land Mobile Network
PUK	Personal Unblocking Key
RF	Radio Frequency
RFI	Radio Frequency Interference

Abbreviation	Definition
RI	Ring Indicator
RMS	Root Mean Square
RTS	Request To Send
RX	Receive
SIM	Subscriber Identification Module
SMA	SubMiniature version A RF connector
SMS	Short Message Service
SNR	Signal-to-Noise Ratio
SPL	Sound Pressure Level
SPK	SpeaKer
SRAM	Static RAM
TCP/IP	Transmission Control Protocol / Internet Protocol
TDMA	Time Division Multiple Access
TU	Typical Urban fading profile
TUHigh	Typical Urban, High speed fading profile
TX	Transmit
TYP	TYPical
VSWR	Voltage Stationary Wave Ratio

2 Packaging

2.1 Contents

The complete package content of the Fastrack Supreme consists of (see):

- one packaging box (A),
- one Fastrack Supreme (B),
- two holding bridles (C),
- one power supply cable with fuse integrated (D)
- a mini notice (E) with:
 - a summary of the main technical features,
 - safety recommendations,
 - EC declaration of conformity.



Figure 1: Complete package contents

2.2 Packaging Box

The packaging box is a carton box (see) with the following external dimensions:

- width: 54.5 mm,
- height: 68 mm,
- length: 108 mm.

A packaging label is slicked on the packaging box cover and supports the:

- WAVECOM logo,
- Product reference (Fastrack Supreme 20 or Fastrack Supreme 10),
- CE marking
- 15-digit IMEI code
- Open AT® Logo
- WEEE logo



Figure 2: Packaging box

The packaging label dimensions are:

- height: 40 mm,
- length: 65 mm.

2.3 Production Labelling

A production label (see Figure 3) located at the Fastrack Supreme back side gives the following information:

- product reference (**Fastrack Supreme 10** or **Fastrack Supreme 20**),
- part number (WM20230),
- CE marking,
- 15-digit IMEI code,
- Open AT® logo
- Made by Wavecom



Figure 3: Production Label

3 General Presentation

3.1 Description

The Fastrack Supreme description is given in the Figure 4 below.

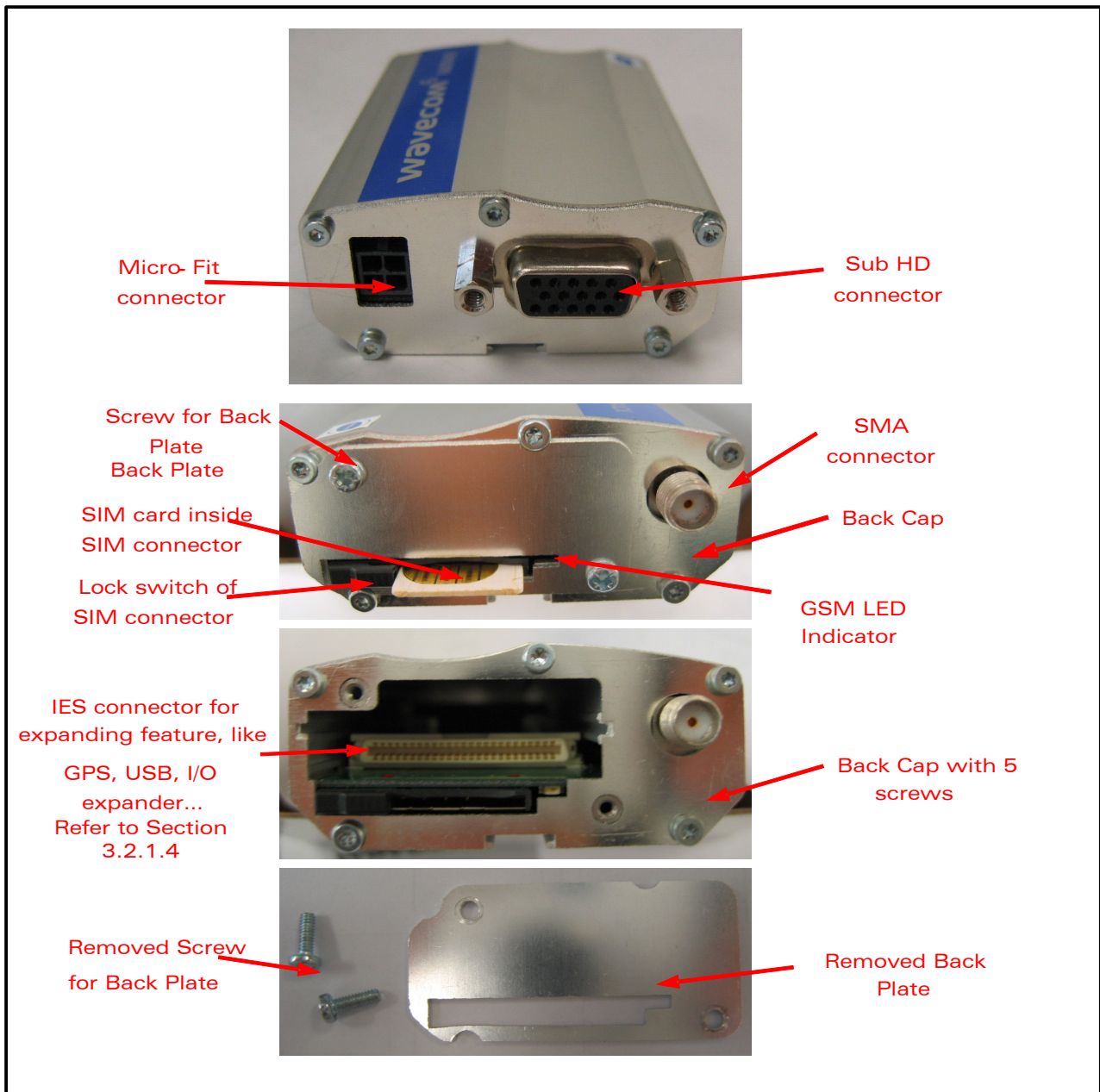

Figure 4: Fastrack Supreme general description

Fastrack Supreme User Guide

General Presentation

CAUTION: Users are free to remove the back plate for IESM board plug in/unplug without voiding the warranty of the Fastrack Supreme. However, the warranty will be voided if unscrewing any screw of the back cap.

In addition, two holding bridles are provided to tighten the Fastrack Supreme on a support.



Figure 5: Fastrack Supreme holding bridles

3.2 External Connections

3.2.1 Connectors

3.2.1.1 Antenna Connector

The antenna connector is a SMA type connector for a 50 Ω RF connection.

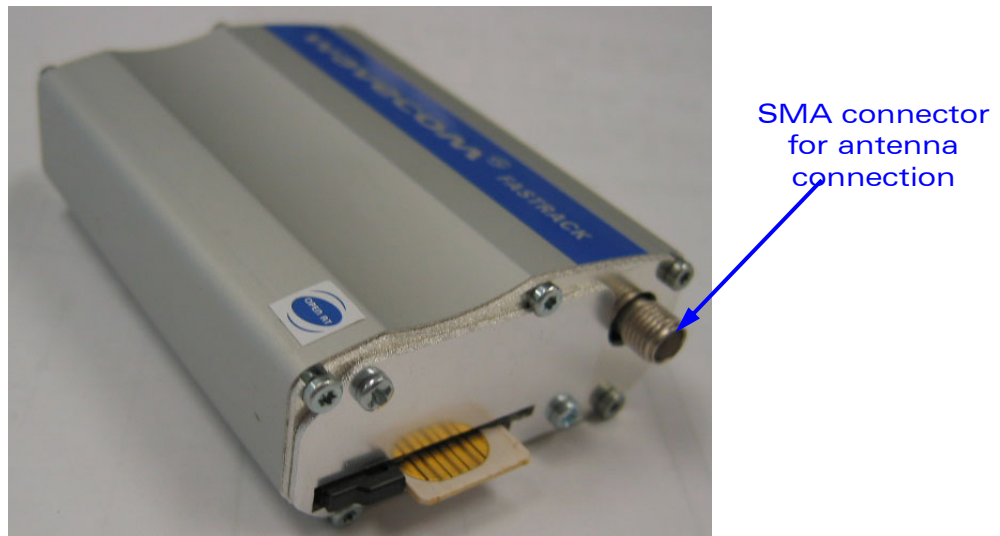

Figure 6: SMA connector for antenna connection

3.2.1.2 Power Supply Connector

The power supply connector is a 4-pin Micro FIT connector for:

- external DC Power Supply connection,
- GPIOs connection (two General Purpose Input/Output signals available).



Figure 7: Power supply connector

Table 1: Power supply connector pin description

Pin #	Signal	I/O	I/O type	Description	Reset State	Comment
1	V+BATTERY	I	Power supply	Battery voltage input: <ul style="list-style-type: none"> 5.5 V Min. 13.2 V Typ. 32 V Max. 		High current
2	GND		Power supply	Ground		
3	GPIO21	I/O	2V8	General Purpose Input/output	Undefined	Not mux
4	GPIO25	I/O	2V8	General Purpose Input/output	Z	Multiplex with INT1

Warning:

Both pin 3 and pin 4 are used by GPIO interface. It is strictly prohibited to connect them to any power supply at the risk of damage to the Fastrack Supreme.

3.2.1.3 Sub HD 15-pin Connector

The Sub D high density 15-pin connector is used for:

- RS232 serial link connection,
- Audio lines (microphone and speaker) connection,
- BOOT and RESET signal connection.

Fastrack Supreme User Guide
General Presentation



Figure 8: Sub HD 15-pin connector

Table 2: Sub HD 15-pin connector description

Pin #	Signal (CCITT / EIA)	I/O	I/O type	Description	Comment
1	CDCD/CT109	O	STANDARD RS232	RS232 Data Carrier Detect	
2	CTXD/CT103	I	STANDARD RS232	RS232 Transmit serial data	
3	BOOT	I	CMOS	Boot	This signal must not be connected. Its use is strictly reserved to Wavecom or competent retailers.
4	CMIC2P	I	Analog	Microphone positive line	
5	CMIC2N	I	Analog	Microphone negative line	
6	CRXD/CT104	O	STANDARD RS232	RS232 Receive serial data	
7	CDSR/CT107	O	STANDARD RS232	RS232 Data Set Ready	

Fastrack Supreme User Guide

General Presentation

Pin #	Signal (CCITT / EIA)	I/O	I/O type	Description	Comment
8	CDTR/CT108-2	I	STANDARD RS232	RS232 Data Terminal Ready	
9	GND	-	GND	Ground	
10	CSPK2P	O	Analog	Speaker positive line	
11	CCTS/CT106	O	STANDARD RS232	RS232 Clear To Send	
12	CRTS/CT105	I	STANDARD RS232	RS232 Request To Send	
13	CRI/CT125	O	STANDARD RS232	RS232 Ring Indicator	
14	RESET	I/O	Schmitt	Supreme Plug & Play reset	Active low
15	CSPK2N	O	Analog	Speaker negative line	

3.2.1.4 IES Connector

The IES connector is a 50 pins board-to-board connector for expanding application features like GPS, USB, I/O expander... Currently there are already 3 IESM boards available for customer to expand the Fastrack Supreme features immediately. They are:

- IESM GPS+USB
- IESM I/O+USB
- IESM I/O+USB+GPS

For detail, please refer to Document in Section 1.1.4.

Fastrack Supreme User Guide

General Presentation

For sales and support, please contact Wavecom sales/FAE or your distributor.

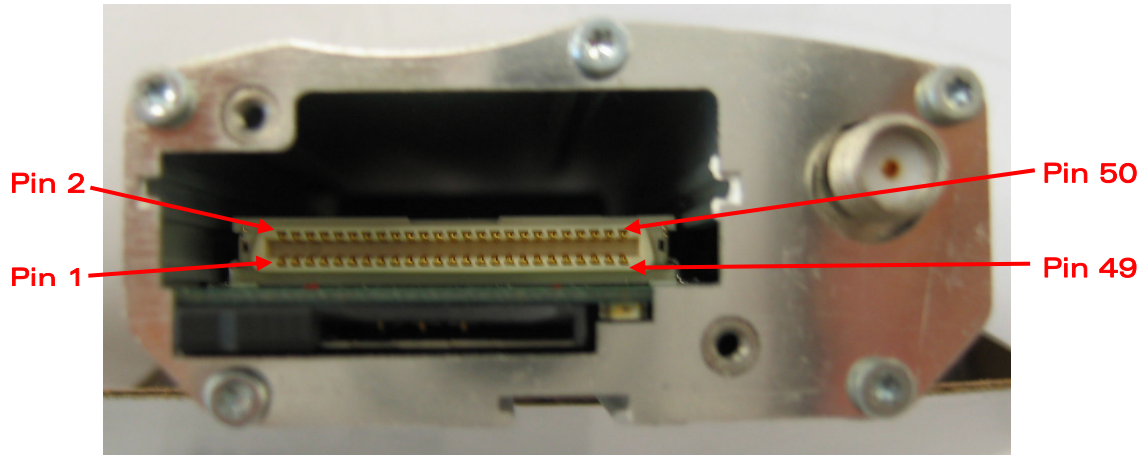

Figure 9: IES connector for feature expansion

Table 3: IES Connector Description

Pin Number	Signal Name		I/O type	Voltage	I/O*	Reset State	Description	Dealing with unused pins
	Nominal	Mux						
1	GND						Ground	
2	GND						Ground	
3	GPIO4	COL0	C8	GSM-1V8	I/O	Pull-up	Keypad column 0	NC
4	GPIO5	COL1	C8	GSM-1V8	I/O	Pull-up	Keypad column 1	NC
5	GPIO6	COL2	C8	GSM-1V8	I/O	Pull-up	Keypad column 2	NC
6	GPIO7	COL3	C8	GSM-1V8	I/O	Pull-up	Keypad column 3	NC
7	VPAD-USB			VPAD-USB	I		USB Power supply input	NC
8	USB-DP			VPAD-USB	I/O		USB Data	NC
9	USB-DM			VPAD-USB	I/O		USB Data	NC
10	GSM-1V8*			GSM-1V8	O		1.8V Supply Output (for GPIO pull-up only)	NC
11	GSM-2V8*			GSM-1V8	O		2.8V Supply Output (for GPIO pull-up only)	NC
12	BOOT			GSM-1V8	I		Not Used	Add a test point / a jumper/ a switch to VCC_1V8 (Pin 10) in case Download Specific mode is used (See product specification for details)

Fastrack Supreme User Guide

General Presentation

Pin Number	Signal Name		I/O type	Voltage	I/O*	Reset State	Description	Dealing with unused pins
	Nominal	Mux						
13	~RESET		C4	GSM-1V8	I/O		RESET Input	NC or add a test point
14	AUX-ADC		A2	Analog	I		Analog to Digital Input	Pull to GND
15	~SPI1-CS	GPIO31	C1	GSM-2V8	O	Z	SPI1 Chip Select	NC
16	SPI1-CLK	GPIO32	C1	GSM-2V8	O	Z	SPI1 Clock	NC
17	SPI1-I	GPIO30	C1	GSM-2V8	I	Z	SPI1 Data Input	NC
18	SPI1-IO	GPIO29	C1	GSM-2V8	I/O	Z	SPI1 Data Input / Output	NC
19	SPI2-CLK	GPIO32	C1	GSM-2V8	O	Z	SPI2 Clock	NC
20	SPI2-IO	GPIO33	C1	GSM-2V8	I/O	Z	SPI2 Data Input / Output	NC
21	~SPI2-CS	GPIO35	C1	GSM-2V8	O	Z	SPI2 Chip Select	NC
22	SPI2-I	GPIO34	C1	GSM-2V8	I	Z	SPI2 Data Input	NC
23	CT104-RXD2	GPIO15	C1	GSM-1V8	O	Z	Auxiliary RS232 Receive	Add a test point for firmware upgrade
24	CT103-TXD2	GPIO14	C1	GSM-1V8	I	Z	Auxiliary RS232 Transmit	(TXD2) Pull-up to VCC_1V8 with 100k Ω and add a test point for firmware update
25	~CT106-CTS2	GPIO16	C1	GSM-1V8	O	Z	Auxiliary RS232 Clear To Send	(CTS2) Add a test point for firmware update
26	~CT105-RTS2	GPIO17	C1	GSM-1V8	I	Z	Auxiliary RS232 Request To Send	(RTS2) Pull-up to VCC_1V8 with 100k Ω and add a test point for firmware update
27	GPIO8	COL4	C8	GSM-1V8	I/O	Pull-up	Keypad column 4	NC
28	GPIO26	SCL	A1	Open Drain	O	Z	I ² C Clock	NC
29	GPIO19		C1	GSM-2V8	I/O	Z		NC
30	GPIO27	SDA	A1	Open Drain	I/O	Z	I ² C Data	NC
31	GPIO20		C1	GSM-2V8	I/O	Undefined		NC
32	INT0	GPIO3	C1	GSM-1V8	I	Z	Interruption 0 Input	If INT0 is not used, it should be configured as GPIO
33	GPIO23	**	C1	GSM-2V8	I/O	Z		NC
34	GPIO22	**	C1	GSM-2V8	I/O	Z		NC
35	~CT108-2-DTR1	GPIO41	C1	GSM-2V8	I	Z	Main RS232 Data Terminal Ready	(DTR1) Pull-up to VCC_2V8 with 100k Ω
36	PCM-SYNC			GSM-1V8	O	Pull-down	PCM Frame Synchro	NC

Fastrack Supreme User Guide

General Presentation

Pin Number	Signal Name		I/O type	Voltage	I/O*	Reset State	Description	Dealing with unused pins
	Nominal	Mux						
37	PCM-IN		C5	GSM-1V8	I	Pull-up	PCM Data Input	NC
38	PCM-CLK			GSM-1V8	O	Pull-down	PCM Clock	NC
39	PCM-OUT			GSM-1V8	O	Pull-up	PCM Data Output	NC
40	AUX-DAC			Analog	O		Digital to Analog Output	NC
41	VCC-2V8			VCC_2V8	O		LDO 2.8V Supply Output	NC
42	GND						Ground	
43	DC-IN			DC-IN from 5.5V~32V DC	O		DC voltage input through Micro-Fit connector	NC
44	DC-IN			DC-IN from 5.5V~32V DC	O		DC voltage input through Micro-Fit connector	NC
45	GND						Ground	
46	4V			4V	O		4V DC/DC converter Output	NC
47	4V			4V	O		4V DC/DC converter Output	NC
48	GND						Ground	
49	GND						Ground	
50	GND						Ground	

3.2.2 Power Supply Cable

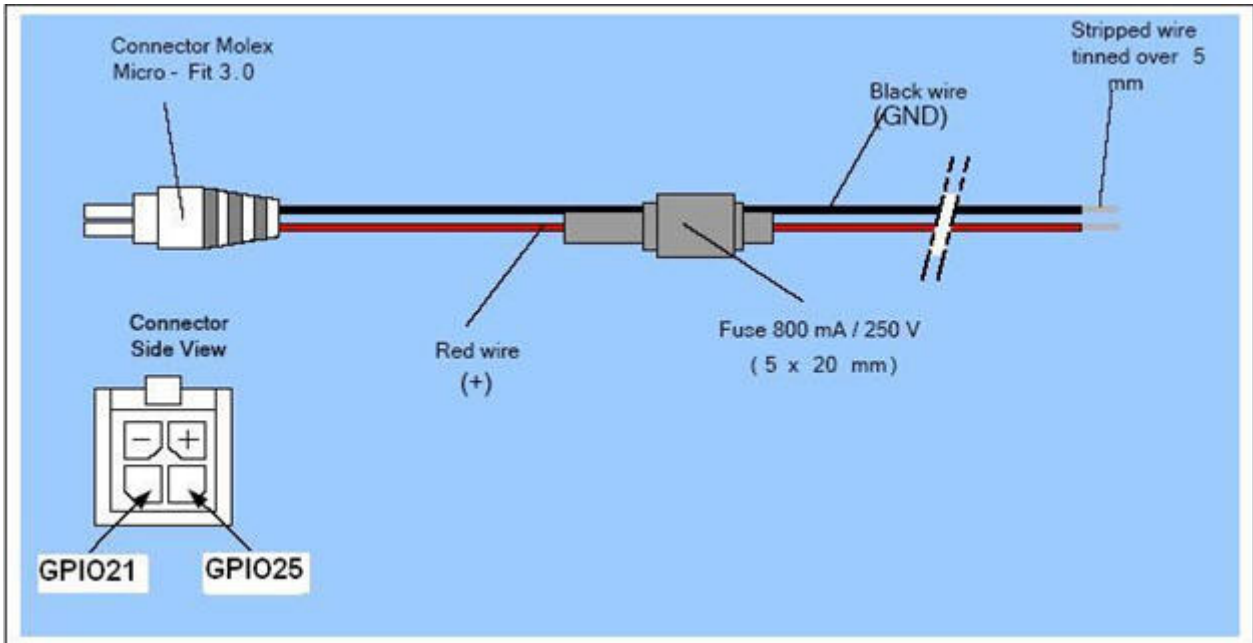

Figure 10: Power supply cable

Component	Characteristics
Micro-Fit connector 4-pin	Part number: MOLEX 43025-0400
Cable	Cable length: ~1.5 m
Wire	Core: tinned copper 24 x 0.2 mm
	Section: 0.75 mm ²

4 Features and Services

4.1 Basic Features and Services

Basic features of the Fastrack Supreme and available services are summarized in the table below.

Table 4: Basic features of the Fastrack Supreme

Features	GSM850 / GSM900	DCS1800 / PCS1900
Open AT®	Open AT® programmable: Native execution of embedded standard ANSI C applications, Custom AT command creation, Custom application library creation, Standalone operation.	
Standard	850MHz / 900 MHz. E-GSM compliant. Output power: class 4 (2W). Fully compliant with ETSI GSM phase 2 + small MS.	1800 MHz / 1900MHz Output power: class 1 (1W). Fully compliant with ETSI GSM phase 2 + small MS.
GPRS	Class 10. PBCCH support. Coding schemes: CS1 to CS4. Compliant with SMG31bis. Embedded TCP/IP stack.	
EGPRS (for Fastrack Supreme 20 only)	Output power: 0.5W	Output power: 0.4W
	Class 10. PBCCH support. Coding schemes: MCS1 to MCS9. Compliant with SMG31bis. Embedded TCP/IP stack.	

Fastrack Supreme User Guide

Features and Services

Features	GSM850 / GSM900	DCS1800 / PCS1900
Interfaces	RS232 (V.24/V.28) Serial interface supporting: <ul style="list-style-type: none"> ▪ Baud rate (bits/s): 300, 600, 1200, 2400, 4800, 9600, 19200, 38400, 57600, 115200, 230400, 460800 and 921600. ▪ Autobauding (bits/s): from 1200 to 921600. 2 General Purpose Input/Output gates (GPIOs) available. 1.8 V / 3 V SIM interface. AT command set based on V.25ter and GSM 07.05 & 07.07. Open AT® interface for embedded application. Open AT® Plug-In Compatible.	
SMS	Text & PDU. Point to point (MT/MO). Cell broadcast.	
Data	Data circuit asynchronous. Transparent and Non Transparent modes. Up to 14.400 bits/s. MNP Class 2 error correction. V42.bis data compression.	
Fax	Automatic fax group 3 (class 1 and Class 2).	
Audio	Echo cancellation Noise reduction Telephony. Emergency calls. Full Rate, Enhanced Full Rate, Half Rate operation and Adaptive Multi-Rate (FR/EFR/HR/AMR). Dual Tone Multi Frequency function (DTMF).	

Fastrack Supreme User Guide

Features and Services

Features	GSM850 / GSM900	DCS1800 / PCS1900
GSM supplement services	Call forwarding. Call barring. Multiparty. Call waiting and call hold. Calling line identity. Advice of charge. USSD	
Other	DC power supply Real Time Clock with calendar Complete shielding	

For other detailed technical characteristics, refer to Section 8.

4.2 Additional NEW Features

4.2.1 Support Additional GSM850/PCS1900 Bands

Apart from GSM900/DCS1800, the Fastrack Supreme Plug & Play now supports also the GSM850/PCS1900 bands. Fastrack Supreme is fully compliant to PTCRB and FCC also.

4.2.2 IES Interface for Easy Expansion of Application Features

The Fastrack Supreme Plug & Play offers a 50 pin Internal Expansion Socket (IES) Interface accessible for customer use. It is the additional interface which is easy for customers to expand their application features without voiding the warranty of the Fastrack Supreme, by simply plugging in an Internal Expansion Socket Module (IESM) board through the matting connector of the IES interface.

Thanks to the flexible IES interface, customers are ready to expand the application features by plugging in the corresponding Internal Expansion Socket Module (IESM) of GPS, I/O expander..., etc.

For brief description of the interface, please refer to Section 3.2.1.4.

For technical detail, please refer to Document [10] or contact your Wavecom distributor or Wavecom FAE.

4.2.3 Serial Port Auto Shut Down or Improving Power Consumption

In order to save power consumption when there is no data communication between the Plug & Play and the DTE, Fastrack Supreme has now implement the Serial Port Auto Shut Down feature. User can activate or deactivate the Serial Port Auto Shut Down mode by simple AT-command.

For detail, please refer to Section 7.4.4.

Fastrack Supreme User Guide

Features and Services

4.2.4 Real Time Clock (RTC) for Saving Date and Time

The Fastrack Supreme has now implemented the Real Time Clock for saving date and time when the Plug & Play is unplugged from the DC power supply through the DC power cable.

For detail, please refer to Section 7.9.

4.2.5 SIM Card Lock Feature

The Fastrack Supreme has now implemented a SIM connector having a carrier with lock. This helps ensuring the user to have proper SIM card insertion and locked before proper use of GSM network.



Figure 11: SIM card lock feature

5 Using the Fastrack Supreme Plug & Play

5.1 Getting Started

5.1.1 Mount the Fastrack Supreme

To mount the Fastrack Supreme on its support, bind it using the holding bridles as shown in the Figure 12 below.

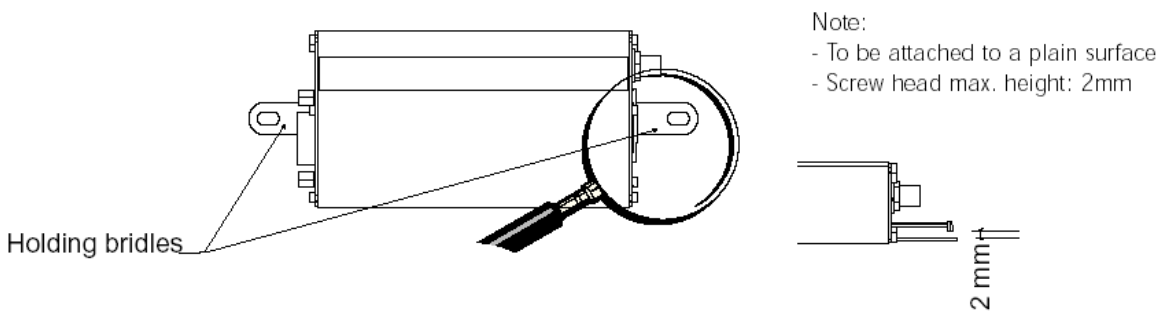
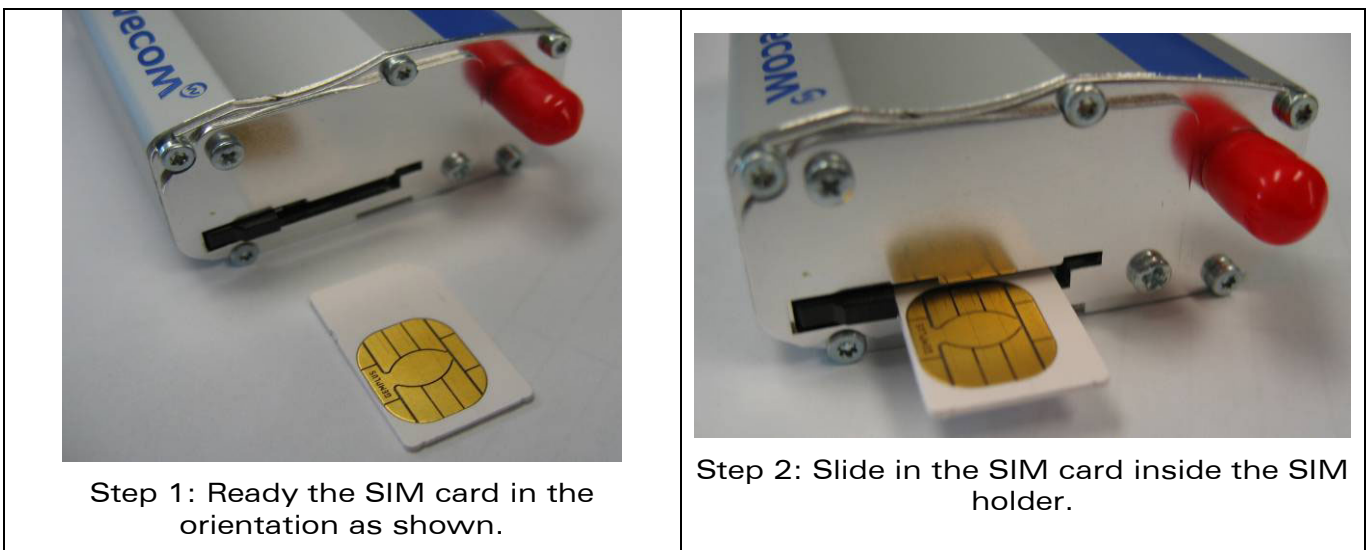

Figure 12: Fastrack Supreme mounting

For the drill template, refer to Figure 20.

5.1.2 Insert/extract the SIM card to/from the Fastrack Supreme

In order to insert the SIM card to the Fastrack Supreme, please follow the procedure in Figure 13.



Fastrack Supreme User Guide
Using the Fastrack Supreme Plug & Play

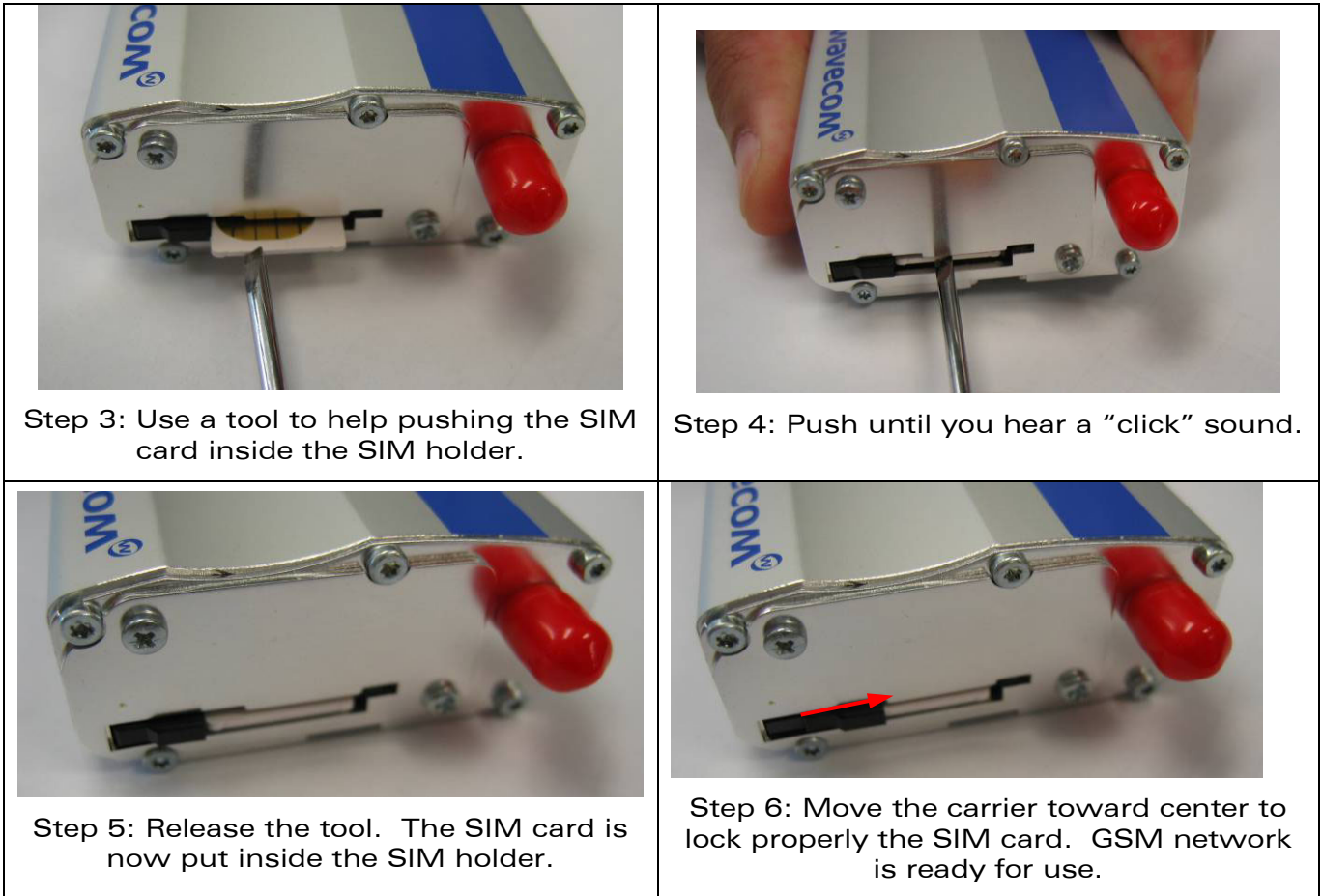
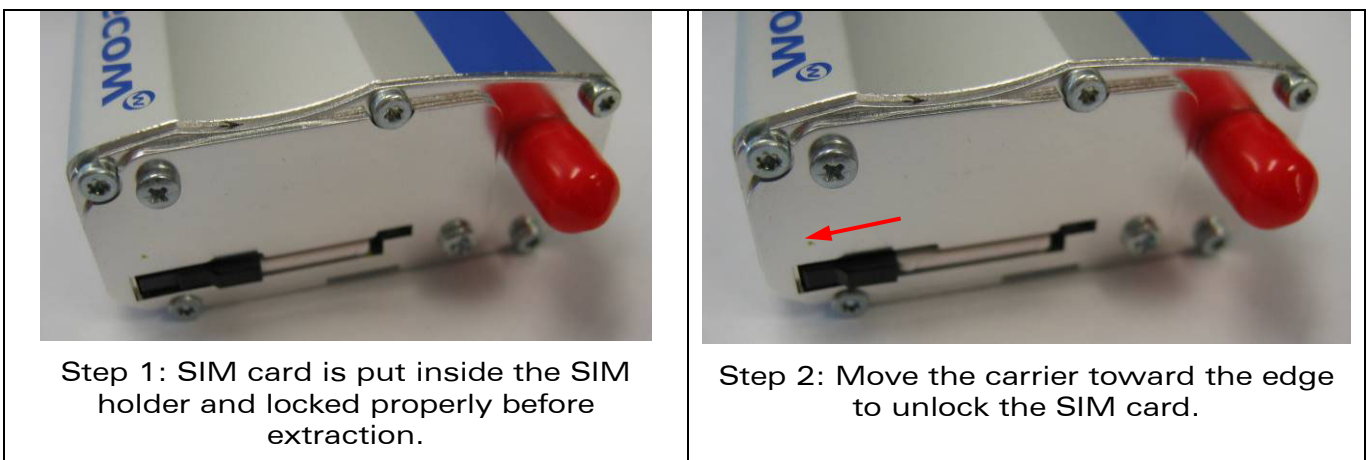

Figure 13: Procedure for SIM card insertion

Caution: Please make sure the SIM card is horizontally inserted into the SIM holder. Otherwise, the SIM card may be blocked inside the Fastrack Supreme.

In order to extract the SIM card from the Fastrack Supreme, please follow the procedure in Figure 14.



Fastrack Supreme User Guide

Using the Fastrack Supreme Plug & Play

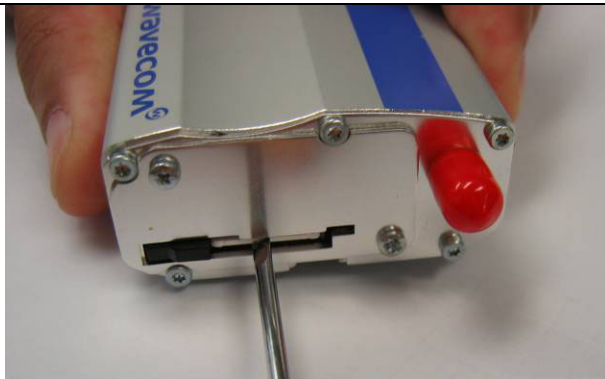

Step 3: Use a tool to help pushing the SIM card a little bit inside the SIM holder until you hear a "click" sound.

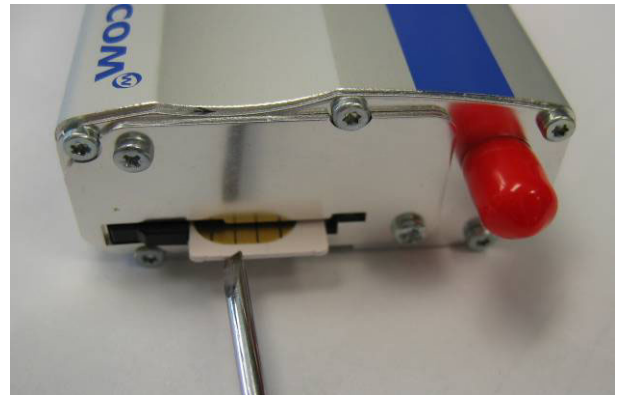

Step 4: The SIM card spring out a little bit.

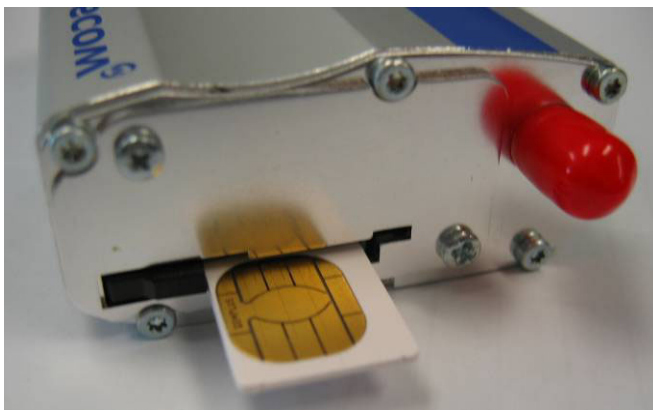

Step 5: You can easily extract the SIM card by hand now.

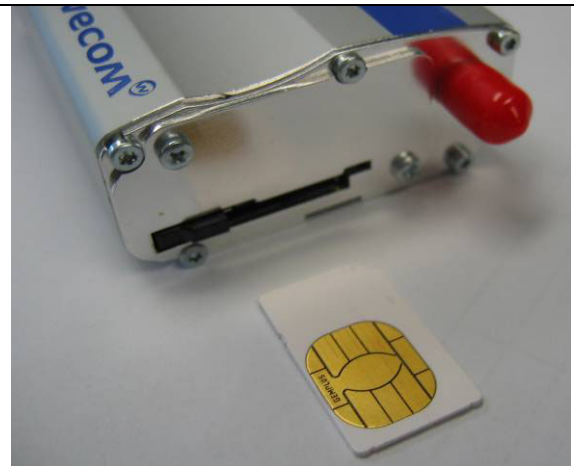

Step 6: SIM card is extracted.

Figure 14: Procedure for SIM card extraction

5.1.3 Set up the Fastrack Supreme

To set up the Fastrack Supreme, perform the following operations:

- Insert the SIM card into the SIM card holder of the Fastrack Supreme.
- Lock the SIM card by sliding the lever towards the SIM card.
- Connect the antenna to the SMA connector.
- Connect both sides of the serial and control cable (15-pin Sub HD connector on the Fastrack Supreme side).
- Connect the power supply cable to the external power supply source.

Fastrack Supreme User Guide

Using the Fastrack Supreme Plug & Play

Note:

For automotive application, it is recommended to connect the V+BATTERY line of the Fastrack Supreme directly to the battery positive terminal.

- Plug the power supply cable into the Fastrack Supreme and switch on the external power supply source.
- The Fastrack Supreme is ready to work. Refer to Section 5.10 for the description of AT commands used to configure the Fastrack Supreme.

5.1.4 Check the communication with the Fastrack Supreme

To check the communication with the Fastrack Supreme, do the following operations:

- Connect the RS232 link between the DTE (port COM) and the Fastrack Supreme (DCE).
- Configure the RS232 port of the DTE as follows:
 - Bits per second: **115.200 bps**,
 - Data bits: **8**,
 - Parity: **None**,
 - Stop bits: **1**,
 - Flow control: **hardware**.
- Using a communication software such as a HyperTerminal, enter the **AT** command. The response of the Fastrack Supreme must be **OK** displayed in the HyperTerminal window.
- If the communication cannot be established with the Fastrack Supreme, do the following:
 - Check the RS232 connection between the DTE and the Fastrack Supreme (DCE),
 - Check the configuration of the port COM used on the DTE.
- Example of AT commands which can be used after getting started the Fastrack Supreme:
 - **AT+CGMI**: Fastrack Supreme answer is "WAVECOM MODEM" when serial link is OK.
 - **AT+CPIN=xxxx**: to enter a PIN code xxxx (if activated).
 - **AT+CSQ**: to verify the received signal strength.
 - **AT+CREG?**: to verify the registration of the Fastrack Supreme Plug & Play on the network.
 - **ATD<phone number>**: to initiate a voice call.
 - **ATH**: to hang up (end of call).

Fastrack Supreme User Guide

Using the Fastrack Supreme Plug & Play

For further information on these AT commands and their associated parameters, refer to "AT Commands Interface Guide" [7].

5.1.5 Reset the Fastrack Supreme

To reset the Fastrack Supreme, a hardware reset signal is available on pin 14 of the Sub HD 15-pin connector (RESET).

The Fastrack Supreme reset is carried out when this pin is low for at least 200 μ s.

Warning This signal has to be considered as an emergency reset only. For further details on the Fastrack Supreme reset, refer to Section 7.7.

5.2 Specific Recommendations when Using the Fastrack Supreme on Trucks

Warning: The power supply connection of the Fastrack Supreme must NEVER be directly connected to the truck battery.

5.2.1 Recommended Power Supply Connection on Trucks

All trucks have a circuit breaker on the exterior of the cabin. The circuit breaker is used for safety reasons: if a fire blazes in the trucks, (for example, on the wiring trunk) the driver may cut the current source to avoid any damage (explosion). The circuit breaker is connected to the truck ground, most often associated with the fuse box.

Most of truck circuit breakers do not cut the Positive Supply line of the battery, but cut the ground line of the later.

Fastrack Supreme User Guide Using the Fastrack Supreme Plug & Play

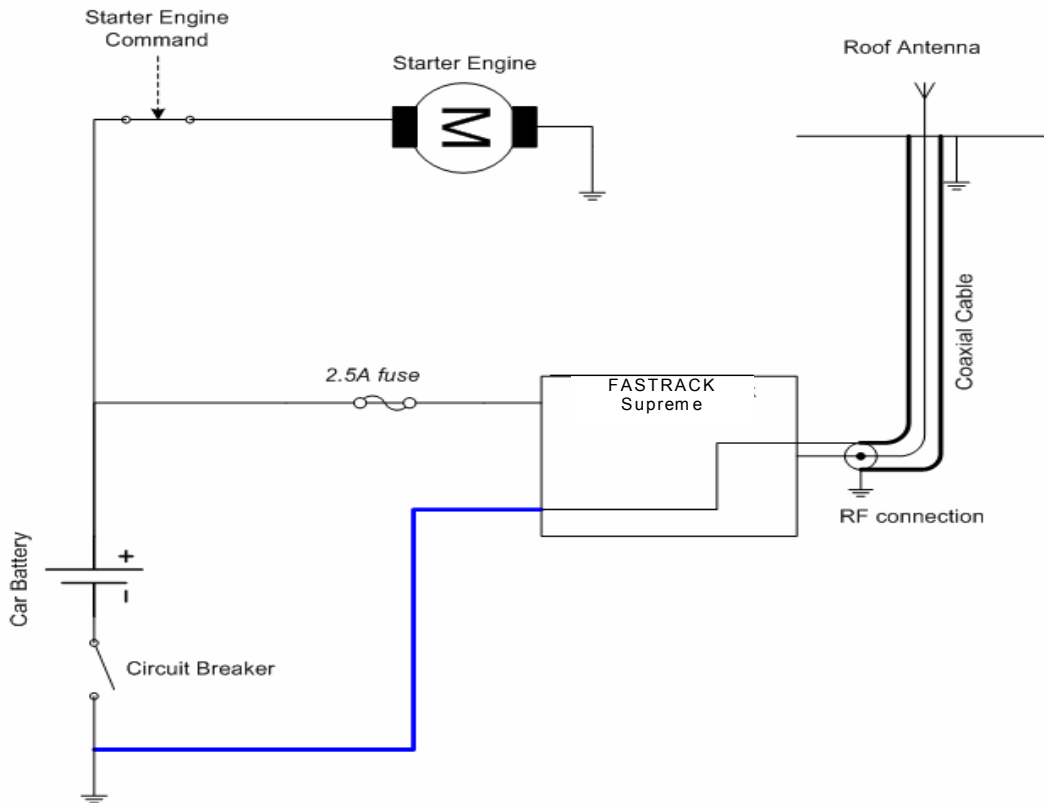

Figure 15: Recommended power supply connection on trucks

Figure 15 gives the recommended power supply connection where the ground connection of the Fastrack Supreme is not directly connected to the battery but is connected after the Circuit Breaker (on the truck ground or the fuse box).

5.2.2 Technical Constraints on Trucks

It is highly not recommended to connect directly the power supply on the battery rather than on the circuit breaker. The Fastrack Supreme may be damaged when starting the truck if the circuit breaker is switched OFF (in this case, the truck ground and the battery ground will be connected through the Fastrack Supreme as shown in the Figure 16).

Fastrack Supreme User Guide Using the Fastrack Supreme Plug & Play

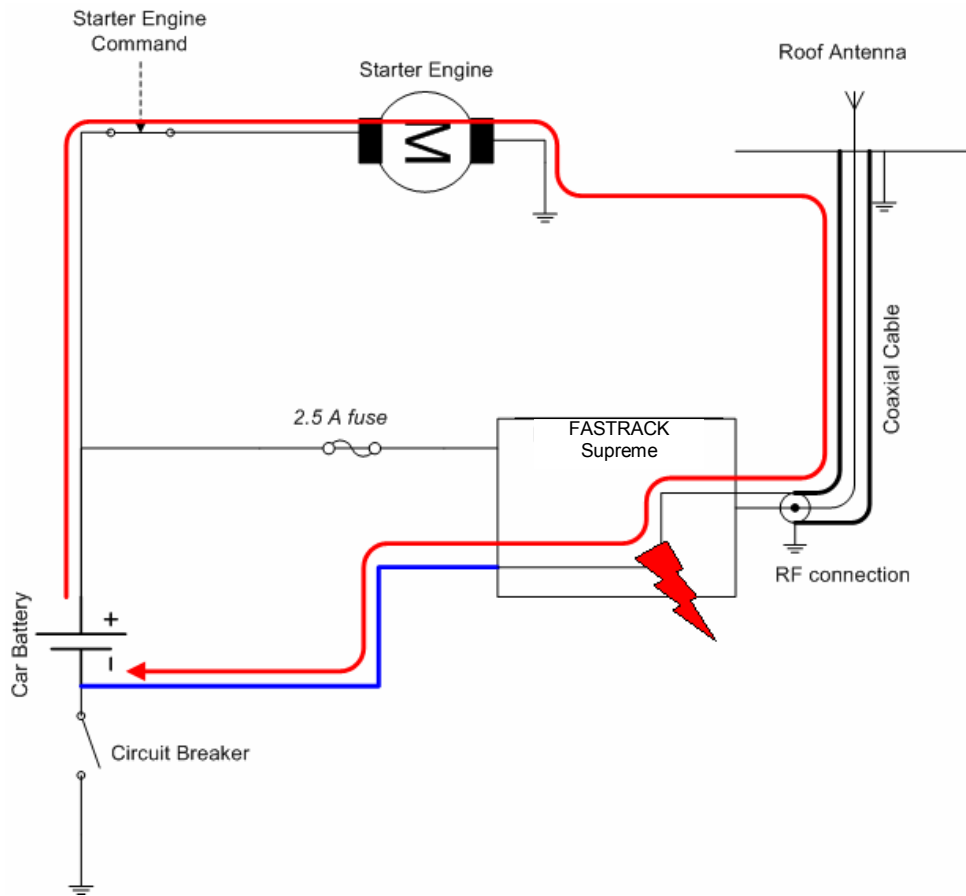

Figure 16: Example of electrical connection which may dramatically damage the Fastrack Supreme

Figure 16 gives an example of electrical connection which may dramatically damage the Fastrack Supreme when its ground connection is directly connected to the battery ground.

In this example, when the circuit breaker is switched OFF, the current flows through the Fastrack Supreme and powers the electrical circuit of the truck (for example, dashboard).

Furthermore, when the Starter Engine command will be used, it will destroy the cables or the Fastrack Supreme.

Since the internal tracks are not designed to support high current (up to 60 A when starting the truck), they will be destroyed.

5.3 Fastrack Supreme Operational Status

The Fastrack Supreme operational status is given by the red LED status located next to the SIM connector on the Fastrack Supreme panel.

The Table 5 below gives the meaning of the various statuses available.

Fastrack Supreme User Guide

Using the Fastrack Supreme Plug & Play

Table 5: Fastrack Supreme operational status

LED Status	LED light activity	Fastrack Supreme Plug & Play status
ON	LED ON permanent	Fastrack Supreme is switched ON but not registered on the network
	LED Flashing slowly	Fastrack Supreme is switched ON and registered on the network, but no communication is in progress (Idle mode)
	LED Flashing rapidly	Fastrack Supreme is switched ON and registered on the network, and a communication is in progress
OFF	LED OFF	Fastrack Supreme is switched OFF, or Flash LED is disabled* by the user.

*: Flash LED can be disabled by user when in Slow Standby mode in order to save power consumption. For detail, please refer to Section 7.10.

5.4 Echo Function Disabled

If no echo is displayed when entering an AT command, that means:

- The "local echo" parameter of your communication software (such as HyperTerminal) is disabled.
- The Fastrack Supreme echo function is disabled.

To enable the Fastrack Supreme echo function, enter the **ATE1**.

When sending AT commands to the Fastrack Supreme by using a communication software, it is recommended:

- to disable the "local echo" parameter of your communication software (such as HyperTerminal),
- to enable the Fastrack Supreme echo function (**ATE1** command).

In a Machine To Machine communication with the Fastrack Supreme, it is recommended to disable the Fastrack Supreme echo function (**ATE0** command) in order to avoid useless CPU processing.

For further information on **ATE0** and **ATE1** commands, refer to "AT Commands Interface Guide" [7].

5.5 Verify the Received Signal Strength

The Fastrack Supreme establishes a call only if the received signal is sufficiently strong.

To verify the received signal strength, do the following operations:

- Using a communication software such as HyperTerminal, enter the AT command **AT+CSQ**.
The response returned has the following format:
+CSQ: <rssi>,<ber> with:
 - **<rssi>** = received signal strength indication,
 - **<ber>** = channel bit error rate.
- Verify the **<rssi>** value returned using the Table 6 below.

Table 6: Values of received signal strength

Value of received signal strength indication (<rssi>)	Interpretation of the received signal strength
0 - 10	Insufficient(*)
11 - 31	Sufficient(*)
32 - 98	Not defined
99	No measure available

(*) Based on general observations.

For further information on AT commands, refer to "AT Commands Interface Guide" [7].

5.6 Check the Pin Code Status

To check that the pin code has been entered, use a communication software such as a HyperTerminal, then enter **AT+CPIN?** command.

The table below gives the main responses returned:

Table 7: AT+CPIN Responses

AT+CPIN response (*)	Interpretation
+CPIN: READY	Code PIN has been entered
+CPIN: SIM PIN	Code PIN has not been entered

(*)For further information on the other possible responses and their meaning, refer to "AT Commands Interface Guide" [7].

Fastrack Supreme User Guide

Using the Fastrack Supreme Plug & Play

5.7 Switch between EU/US Band(s)

To switch between EU/US band(s) for the Fastrack Supreme, use a communication software such as a HyperTerminal, then enter **AT+WMBS=<band>[,<param>]** command.

The table below gives the commands for various band(s) selection:

Table 8: AT+WMBS Band Selection

AT+WMBS response (*)	Interpretation
AT+WMBS=0, x	Select mono band mode 850MHz.
AT+WMBS=1, x	Select mono band mode extended 900MHz
AT+WMBS=2, x	Select mono band mode 1800MHz
AT+WMBS=3, x	Select mono band mode 1900MHz
AT+WMBS=4, x	Select dual band mode 850/1900MHz
AT+WMBS=5, x	Select dual band mode extended 900MHz/1800MHz
AT+WMBS=6, x	Select dual band mode extended 900MHz/1900MHz

(*)For further information on the other possible responses and their meaning, refer to "AT Commands Interface Guide" [7].

Remark:

x=0 : The Plug & Play will have to be reset to start on specified band(s).

x=1 : The change is effective immediately. This mode is forbidden while in communication and during Plug & Play initialization.

Refer to "AT Commands Interface Guide" [7] for further information on AT commands.

5.8 Check the Band(s) Selection

To check the band selection for the Fastrack Supreme, use a communication software such as a HyperTerminal, then enter **AT+WMBS?** command.

The table below gives the main responses returned:

Table 9: AT+WMBS Responses

AT+WMBS response (*)	Interpretation
+WMBS: 0, x	Mono band mode 850MHz is selected
+WMBS: 1, x	Mono band mode extended 900MHz is selected
+WMBS: 2, x	Mono band mode 1800MHz is selected
+WMBS: 3, x	Mono band mode 1900MHz is selected

Fastrack Supreme User Guide

Using the Fastrack Supreme Plug & Play

AT+WMBS response (*)	Interpretation
+WMBS: 4, x	Dual band mode 850/1900MHz are selected
+WMBS: 5, x	Dual band mode extended 900MHz/1800MHz are selected
+WMBS: 6, x	Dual band mode extended 900MHz/1900MHz are selected

(*)For further information on the other possible responses and their meaning, refer to "AT Commands Interface Guide" [7].

5.9 Verify the Fastrack Supreme Network Registration

1. Make sure a valid SIM card has been previously inserted and locked in the Fastrack Supreme SIM card holder.
2. Using a communication software such as a HyperTerminal, enter the following AT commands:

- a. **AT+CPIN=xxxx** to enter PIN code xxxx.
- b. **AT+WMBS?** To check the current band setting in the Plug & Play
- c. **AT+WMBS=<Band> [,<param>]** To switch band/mode when needed
- d. **AT+CREG?** . To ascertain the registration status.

The format of the returned response is as follows:

+CREG: <mode>,<stat> with:

- **<mode>** = unsolicited registration message configuration,
- **<stat>** = registration state.

3. Verify the state of registration according the returned value given in the table below.

Table 10: Values of network registration

Returned Value (*) <mode>,<stat>	Network registration
+CREG: 0,0	No (not registered)
+CREG: 0,1	Yes (registered, home network)
+CREG: 0,5	Yes (registered, roaming)

(*)For further information on the other returned values and their meaning, refer to "AT Commands Interface Guide" [7].

Fastrack Supreme User Guide

Using the Fastrack Supreme Plug & Play

If the Fastrack Supreme is not registered, perform the following procedure:

- Check the connection between the Fastrack Supreme and the antenna.
- Verify the signal strength to determine the received signal strength (refer to Section 5.5).

Note: For information on AT command relating to the network registration in GPRS mode, and in particular: CGREG, CGCLASS, CGATT, refer to "AT Commands Interface Guide" [7].

5.10 Main AT Commands for the Plug & Play

The table below lists the main AT commands required for starting the Plug & Play.

For other AT commands available or further information on the AT commands, refer to "AT Commands Interface Guide" [7].

Table 11: Main usual AT commands for the Plug & Play

Description	AT commands	Fastrack Supreme Plug & Play response	Comment
Check for selected band(s)	AT+WMBS?	+WMBS:<Band>,<ResetFlag> OK	Current selected band mode is return
Band(s) switch	AT+WMBS=<Band>	OK	Band switch is accepted, Plug & Play has to be reset for change to be effective
	AT+WMBS=<Band>,0	OK	Band switch is accepted, Plug & Play has to be reset for change to be effective
	AT+WMBS=<Band>,1	OK	Band switch is accepted and GSMS stack restarted
	AT+WMBS=<Band>	+CME ERROR: 3	Band not allowed

Fastrack Supreme User Guide

Using the Fastrack Supreme Plug & Play

Description	AT commands	Fastrack Supreme Plug & Play response	Comment
Enter PIN Code	AT+CPIN=xxxx (xxxx = PIN code)	OK	PIN Code accepted.
		+CME ERROR: 16	Incorrect PIN Code (with +CMEE = 1 mode) (1*)
		+CME ERROR: 3	PIN code already entered (with +CMEE = 1 mode) (1*)
Network registration checking	AT+CREG?	+CREG: 0,1	Fastrack Supreme Plug & Play registered on the network.
		+CREG: 0,2	Fastrack Supreme Plug & Play not registered on the network, registration attempt.
		+CREG: 0,0	Fastrack Supreme Plug & Play not registered on the network, no registration attempt.
Receiving an incoming call	ATA	OK	Answer the call.
Initiate a call	ATD<phone number>; (Don't forget the « ; » at the end for « voice » call)	OK	Communication established.
		+CME ERROR: 11	PIN code not entered (with +CMEE = 1 mode).
		+CME ERROR: 3	AOC credit exceeded or a communication is already established.

Fastrack Supreme User Guide

Using the Fastrack Supreme Plug & Play

Description	AT commands	Fastrack Supreme Plug & Play response	Comment
Initiate an emergency call	ATD112; (Don't forget the « ; » at the end for « voice » call)	OK	Communication established.
Communication loss		NO CARRIER	
Hang up	ATH	OK	
Store the parameters in EEPROM	AT&W	OK	The configuration settings are stored in EEPROM.

(1*) The command "AT+CMEE=1" switch to a mode enabling more complete error diagnostics.

5.11 Firmware Upgrade Procedure

The firmware upgrade procedure is used to update the firmware embedded into the Fastrack Supreme.

That procedure consists in downloading the firmware into internal memories through the RS232 serial link available on the SUB-D 15-pin connector.

Refer to "Firmware upgrade procedure" document for a detailed description of this procedure.

6 Troubleshooting

This section of the document describes possible problems encountered when using the Fastrack Supreme and their solutions.

To review other troubleshooting information, refer the 'FAQs' (Frequently Asked Questions) page at www.wavecom.com/fastracksupreme.

6.1 No Communication with the Fastrack Supreme through the Serial Link

If the Fastrack Supreme does not answer to AT commands through the serial link, refer to the table below for possible causes and solutions.

Table 12: Solutions for no connection with Fastrack Supreme through serial link

If the Supreme returns	then ask	Action
Nothing	Is the Fastrack Supreme powered correctly?	Make sure the external power supply is connected to the Fastrack Supreme and provides a voltage in the range of 5.5 V to 32 V.
	Is the serial cable connected at both sides?	Check the serial cable connection
	Does the serial cable follow correctly pin assignment shown in paragraph 3.2.1.2.	Connect the cable by following pin assignment given in paragraph 3.2.1.1.
Nothing or non-significant characters	Is the communication program properly configured on PC?	Ensure the setting of the communication program is fit to setting of Fastrack Supreme. Fastrack Supreme factory setting is: Data bits = 8 Parity = none Stop bits = 1 Baud = 115 200 bps. Flow control = hardware
	Is there another program interfering with the communication program (i.e. Conflict on communication port access)	Close the interfering program.

6.2 Receiving "ERROR" Message

The Fastrack Supreme returns an "ERROR" message (in reply to an AT command) in the following cases:

- AT command syntax is incorrect: check the command syntax (refer to "AT Commands Interface Guide" [7]),
- AT command syntax is correct, but transmitted with wrong parameters:
- Enter the **AT+CMEE=1** command in order to change the error report method to the verbose method, which includes the error codes.
- Enter again the AT command which previously caused the reception of "ERROR" message in order to get the Mobile Equipment error code.

When the verbose error report method is enabled, the response of the Fastrack Supreme in case of error is as follows:

- Either +CME ERROR: <error result code>.,
- Or +CMS ERROR: <error result code>.

Refer to "AT Commands Interface Guide" [7] for error result code description and further details on the **AT +CMEE** command.

Note: It is strongly recommended to always enable the verbose error report method to get the Mobile Equipment error code (enter **AT +CMEE=1** command).

6.3 Receiving "NO CARRIER" Message

If the Fastrack Supreme returns a "NO CARRIER" message upon an attempted call (voice or data), then refer to the table below for possible causes and solutions.

Fastrack Supreme User Guide

Troubleshooting

Table 13: Solutions for "NO CARRIER" message

If the Supreme returns...	Then ask...	Action...
"NO CARRIER"	Is the received signal strong enough?	Refer to section 5.5 to verify the strength of the received signal.
	Is the Fastrack Supreme registered on the network?	Refer to section 5.9 to verify the registration.
	Is the antenna properly connected?	Refer to section 8.2.7.3 for antenna requirements.
	Is the band selection correction?	Refer to Section 7.2 for band switch
"NO CARRIER" (when trying to issue a voice communication)	Is the semicolon (;) entered immediately after the phone number in the AT command?	Ensure that the semicolon (;) is entered immediately after the phone number in the AT command. e.g. ATD##### ;
"NO CARRIER" (when trying to issue a data communication)	Is the SIM card configured for data / fax calls?	Configure the SIM card for data / fax calls (Ask your network provider if necessary).
	Is the selected bearer type supported by the called party?	Ensure that the selected bearer type is supported by the called party.
	Is the selected bearer type supported by the network?	Ensure that the selected bearer type is supported by the network. If no success, try bearer selection type by AT command: AT+CBST=0,0,3

If the Fastrack Supreme returns a "NO CARRIER" message, you may have the **extended error code** by using AT command **AT+CEER**. Refer to the table below for interpretation of **extended error code**.

Fastrack Supreme User Guide
Troubleshooting

Table 14: Interpretation of extended error code

Error Code	Diagnostic	Hint
1	Unallocated phone number	
16	Normal call clearing	
17	User busy	
18	No user responding	
19	User alerting, no answer	
21	Call rejected	
22	Number changed	
31	Normal, unspecified	
50	Requested facility not subscribed	Check your subscription (data subscription available?).
68	ACM equal or greater than ACMmax	Credit of your pre-paid SIM card expired.
252	Call barring on outgoing calls	
253	Call barring on incoming calls	
3, 6, 8, 29, 34, 38, 41, 42, 43, 44, 47, 49, 57, 58, 63, 65, 69, 70, 79, 254	Network causes	See "AT Commands Interface Guide" [7] for further details or call network provider.

Note: For all other codes, and/or details, see AT commands documentation [7].

7 Functional Description

7.1 Architecture

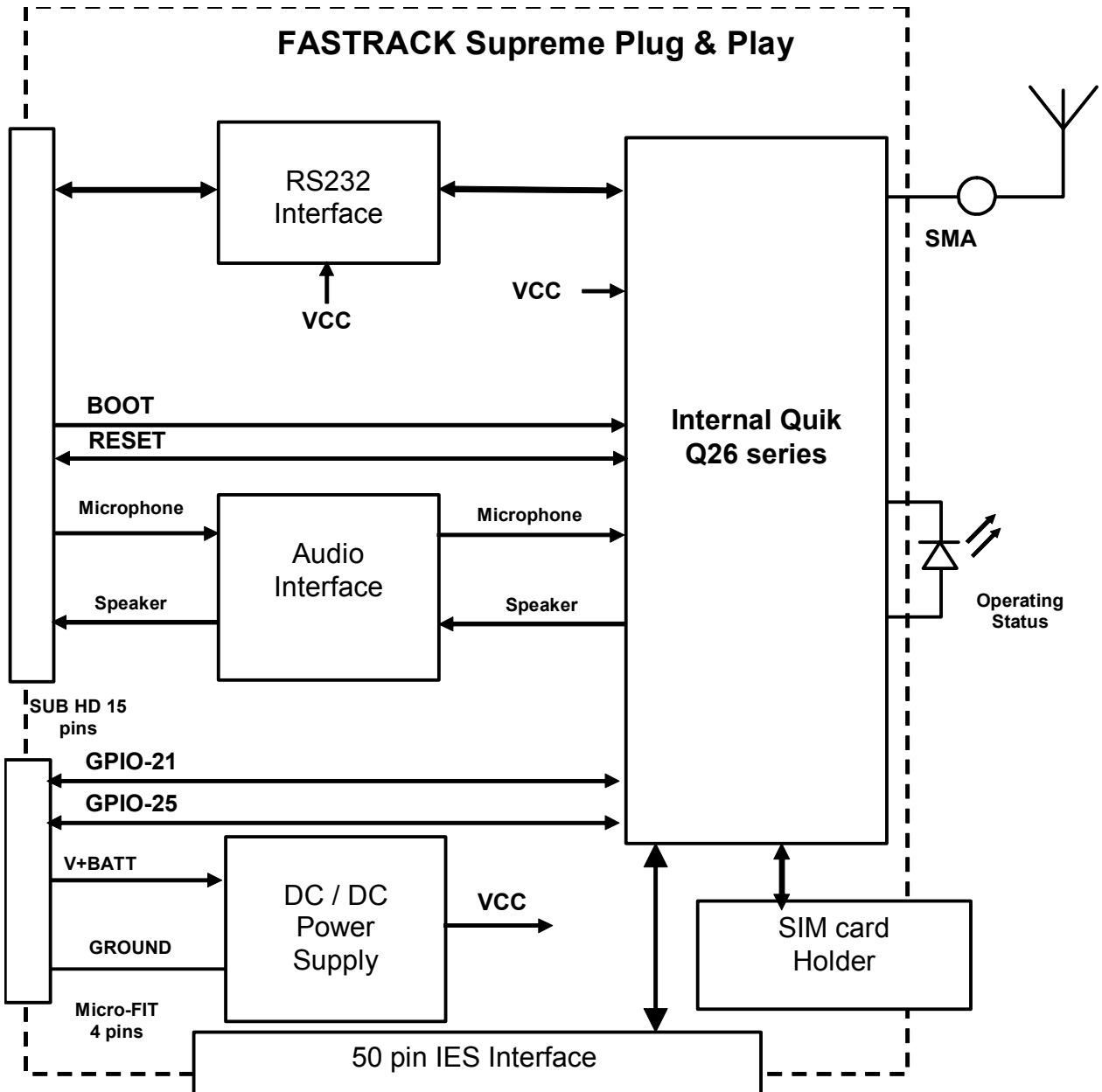

Figure 17: Functional architecture

7.2 EU and US Bands

7.2.1 General Presentation

The Fastrack Supreme is a quad band Plug & Play. It supports either EU bands (EGSM900/DCS1800) or US bands (GSM850/ PCS1900), depending on the band setting within the Plug & Play. Users are free to switch between EU bands and US bands by simple AT commands when the selected bands are supported.

7.2.2 AT COMMAND for Bands Switch

EU/US band is easily switched/checked by AT command **AT+WMBS**.

For detail, please refer to Section 5.7 and 5.8.

7.3 Power Supply

7.3.1 General Presentation

The Fastrack Supreme is supplied by an external DC voltage (V+BATTERY) from +5.5 V to +32 V at 2.2 A.

Main regulation is made with an internal DC/DC converter in order to supply all the internal functions with a DC voltage.

Correct operation of the Fastrack Supreme in communication mode is not guaranteed if input voltage (V+BATTERY) falls below 5.5 V.

Note: The minimum input voltage specified here is at the Fastrack Supreme input. Be careful of the input voltage decrease caused by the power cable. See paragraph 8.2.1 for more information.

7.3.2 Protections

The Fastrack Supreme is protected by a 800 mA / 250 V fuse directly bonded on the power supply cable.

The Fastrack Supreme is also protected against voltage over +32 V.

Filtering guarantees:

- EMI/RFI protection in input and output,
- Signal smoothing.

7.4 RS232 Serial Link

7.4.1 General Presentation

The RS232 interface performs the voltage level adaptation (V24/CMOS \leftrightarrow V24/V28) between the internal Fastrack Supreme Plug & Play (DCE) and the external world (DTE).

The RS232 interface is internally protected (by ESD protection) against electrostatic surges on the RS232 lines.

Filtering guarantees:

- EMI/RFI protection in input and output,
- Signal smoothing.

Signals available on the RS232 serial link are:

- TX data (CT103/TX),
- RX data (CT104/RX),
- Request To Send (CT105/RTS),
- Clear To Send (CT106/CTS),
- Data Terminal Ready (CT108-2/DTR),
- Data Set Ready (CT107/DSR),
- Data Carrier Detect (CT109/DCD),
- Ring Indicator (CT125/RI).

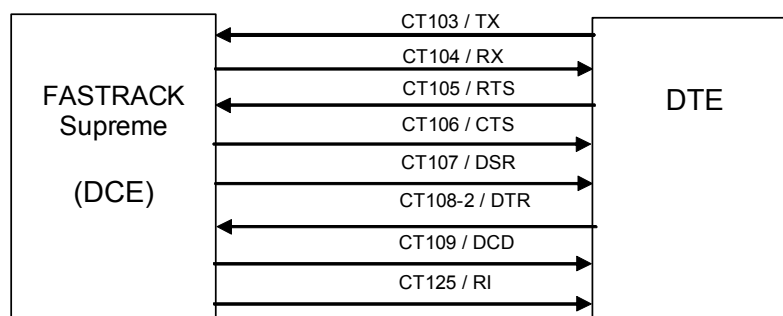

Figure 18: RS232 Serial Link signals

RS232 interface has been designed to allow flexibility in the use of the serial interface signals. However, the use of TX, RX, CTS and RTS signals is mandatory, which is not the case for DTR, DSR, DCD and RI signals which can be not used.

Fastrack Supreme User Guide

Functional Description

7.4.2 Autobauding Mode

The autobauding mode allows the Fastrack Supreme to detect the baud rate used by the DTE connected to the RS232 serial link.

Autobauding mode is controlled by AT commands. See "AT Commands Interface Guide" [7] for details on this function.

7.4.3 Pin Description

Signal	Sub HD connector Pin number	I/O	I/O type RS232 STANDARD	Description
CTXD/CT103	2	I	TX	Transmit serial data
CRXD/CT104	6	O	RX	Receive serial data
CRTS/CT105	12	I	RTS	Request To Send
CCTS/CT106	11	O	CTS	Clear To Send
CDSR/CT107	7	O	DSR	Data Set Ready
CDTR/CT108-2	8	I	DTR	Data Terminal Ready
CDCD/CT109	1	O	DCD	Data Carrier Detect
CRI/CT125	13	O	RI	Ring Indicator
CT102/GND	9		GND	Ground

7.4.4 Serial Port Auto shut down Feature

The UART1 can be shut down when there is no activity between the DTE and the Fastrack Supreme Plug & Play. This can help for improving power consumption performance.

Serial Port Auto shut down feature is easily controlled by AT command **AT+WASR**.

- **AT+WASR=1** for entering the serial port auto shut down mode
- **AT+WASR=0** for exiting the serial port auto shut down mode

Refer to "AT Commands Interface Guide" [7] for further information on AT commands.

CAUTION: GPIO24 is reserved for serial port auto shut down feature. It is prohibited for customer use. Improper access to GPIO24 by customer may lead to unexpected behavior on UART1 performance.

7.5 General Purpose Input/Output (GPIO)

The Fastrack Supreme provides two General Purpose Input / Output lines available for external use: GPIO21 and GPIO25.

These GPIOs may be controlled by AT commands:

- **AT+WIOV** for a write access to the GPIO value, when the GPIO is used as an output,
- **AT+WIOR** for a read access to the GPIO value, when the GPIO is used as an input.

Refer to "AT Commands Interface Guide" [7] for further information on AT commands.

After reset, both GPIOs are configured as inputs. The **AT+WIOM** command has to be used to change this configuration (refer to "AT Commands Interface Guide" [7] for further details).

Pin description

Signal	Power Supply connector (4-pin Micro-Fit)	I/O	I/O Voltage	Reset state	Description	Multiplex with
GPIO21	3	I/O	2V8	Undefined	General Purpose I/O	No mux
GPIO25	4	I/O	2V8	Z	General Purpose I/O	INT1

Notes:

- The power supply cable may need to be modified due to the GPIO signals (GPIO21 & GPIO25) available on the 4-pin Micro-FIT connector of the Fastrack Supreme.
- The previous generation M1306B have GPIO4 and GPIO5 being replaced by GPIO21 and GPIO25 respectively, for which both are of LOW level at reset state.

7.6 BOOT

This signal must not be connected. Its use is strictly reserved to Wavecom or competent retailers.

7.7 RESET

7.7.1 General Presentation

This signal is used to force a reset procedure by providing low level during at least 200 μ s.

This signal must be considered as an emergency reset only. A reset procedure is automatically driven by an internal hardware during the power-up sequence.

This signal may also be used to provide a reset to an external device. It then behaves as an output. If no external reset is necessary, this input may be left open, if used (emergency reset), it has to be driven either by an open collector or an open drain output:

- RESET pin 14 = 0, for Fastrack Supreme Reset,
- RESET pin 14 = 1, for normal mode.

Pin description

Signal	Sub HD 15-Pin connector Pin number	I/O	I/O type	Voltage	Description
RESET	14	I/O	Open Drain	1V8	Fastrack Supreme Reset

Additional comments on RESET:

The RESET process is activated either by the external RESET signal or by an internal signal (coming from a RESET generator). This automatic reset is activated at Power-up.

The Fastrack Supreme remains in RESET mode as long as the RESET signal is held low.

Caution: This signal should be used only for "emergency" reset.

A software reset is always preferred to a hardware reset.

Note: See "AT Commands Interface Guide" [7] for further information on software reset.

7.7.2 Reset Sequence

To activate the "emergency" reset sequence, the RESET signal has to be set to low for 200 μ s minimum.

Fastrack Supreme User Guide

Functional Description

As soon as the reset is done, the AT interface answers "OK" to the application. For this, the application must send **ATJ**.

If the application manages hardware flow control, the AT command may be sent during the initialization phase. Another solution is to use the **AT+WIND** command to get an unsolicited status from the Fastrack Supreme.

For further details, refer to AT commands "AT Commands Interface Guide" [7].

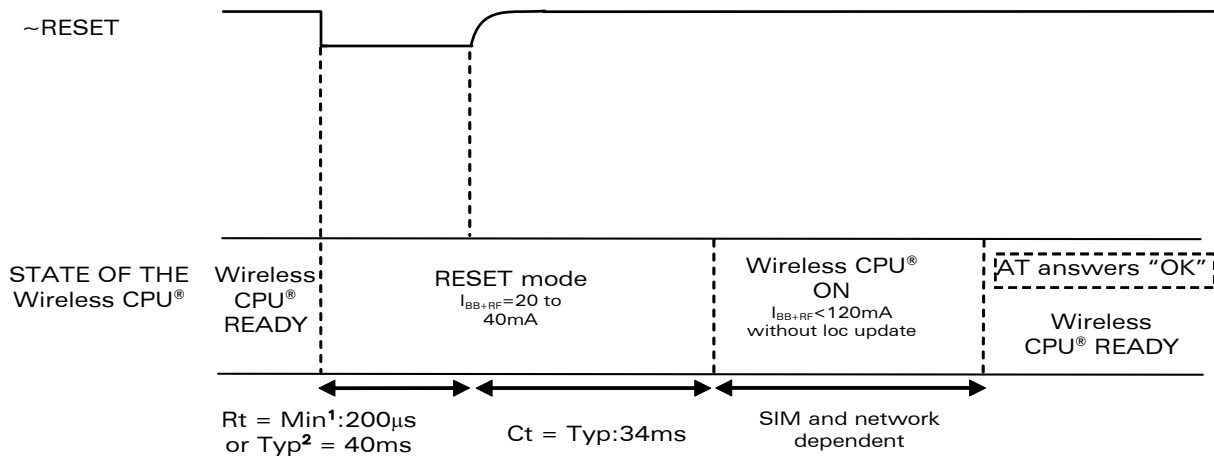

Figure 19: Reset sequence diagram

7.8 Audio

Audio interface is a standard one for connecting a phone handset.

Echo cancellation and noise reduction features are also available to improve the audio quality in case of hand-free application.

7.8.1 Microphone Inputs

The microphone inputs are differential ones in order to reject common mode noise and TDMA noise.

They already include the convenient biasing for an electret microphone (0.5 mA and 2 Volts) and are ESD protected.

This electret microphone may be directly connected to these inputs allowing an easy connection to a handset.

The microphone impedance must be around 2 kΩ.

Fastrack Supreme User Guide

Functional Description

AC coupling is already embedded in the Wireless CPU®.

The gain of the microphone inputs is internally adjusted and may be tuned from 7 dB to 35 dB using an **AT +VGT** command (refer to AT commands documentation [7]).

Pin description

Signal	Sub D 15-pin Pin #	I/O	I/O type	Description
CMIC2P	4	I	Analog	Microphone positive input
CMIC2N	5	I	Analog	Microphone negative input

7.8.2 Speaker Outputs

This connection is differential to reject common mode noise and TDMA noise.

Speaker outputs are connected to internal push-pull amplifiers and may be loaded down between 32 to 150 Ohms and up to 1 nF (see details in table *Speaker gain vs Max output voltage*, in "AT Commands Interface Guide" [7]). These outputs may be directly connected to a speaker.

The output power may be adjusted by step of 2 dB. The gain of the speaker outputs is internally adjusted and may be tuned using an **AT +VGR** command (refer to AT commands documentation [7]).

Pin description

Signal	Sub D 15-pin Pin #	I/O	I/O type	Description
CSPK2P	10	O	Analog	Speaker positive output
CSPK2N	15	O	Analog	Speaker negative output

7.9 Real Time Clock (RTC)

The Fastrack Supreme has now implemented the Real Time Clock for saving date and time when the Plug & Play is unplugged from the DC power supply through the DC power cable.

Item		Min	Typical	Max
Charging Time start from fully discharged to fully charged			940 min	
RTC Time Period*	Guarantee		2475 min	
	Non-guarantee		5225 min	

Fastrack Supreme User Guide

Functional Description

Remark:

1. This RTC time period is measured when the RTC battery is fully charged before the Fastrack Supreme is being unplugged from the DC power source.
2. This RTC time period is for temperature from -20°C to +60°C. Once the operating/storage temperature is beyond this range, this time period is not guaranteed.

Caution: When the Fastrack Supreme is shipped out, the charging voltage of the RTC battery is not guaranteed. Once the Fastrack Supreme is on power, the RTC battery will start charging and the RTC feature can then be resumed.

7.10 FLASH LED

The Fastrack Supreme has a red LED indicator to show the status of the GSM network. For detail description of the various status, please refer to Section 5.3.

However, during operation mode of Slow Standby, there will be no network registration and so the red LED indicator will always be ON. It is possible for user to deactivate the LED indication during Slow Standby mode, in order to reduce power consumption.

The Flash LED can be deactivated by AT command `at+whcnf=1,0`

The Flash LED can be activated by AT command `at+whcnf=1,1`

However, the new setting will be taken into account only after a restart. For detail, please refer to Document [7].

8 Technical Characteristics

8.1 Mechanical Characteristics

Table 15: Mechanical characteristics

Dimensions	73 x 54.5 x 25.5 mm (excluding connectors)
Overall Dimension	88 x 54.5 x 25.5 mm
Weight	≈ 89 grams (Fastrack Supreme only) ≈ 126 grams (Fastrack Supreme + bridles + power supply cable)
Volume	101.5 cm ³
Housing	Aluminum profiled

The next page gives the dimensioning diagram of the Fastrack Supreme including the clearance areas to take into account for the Fastrack Supreme installation.

Fastrack Supreme User Guide Technical Characteristics

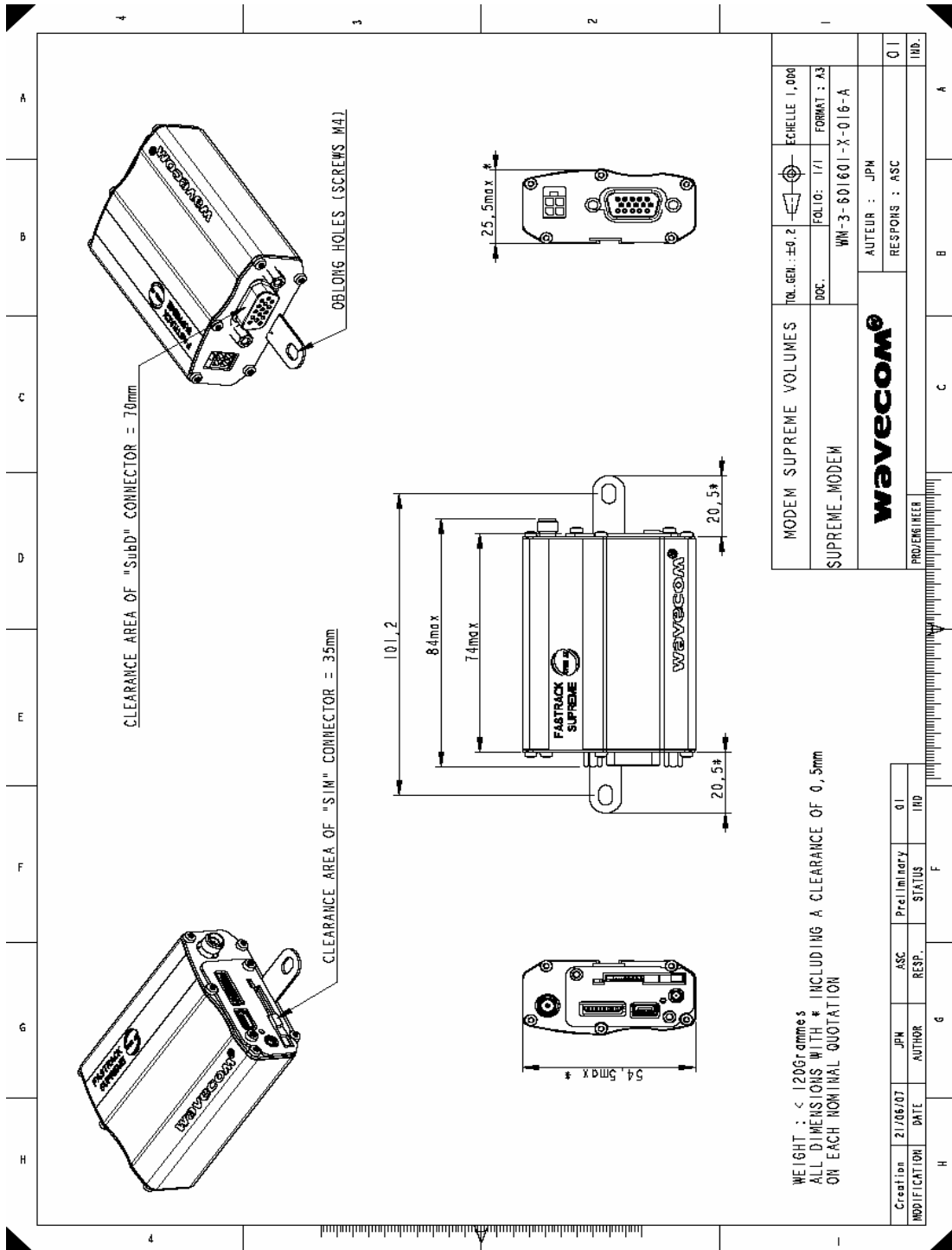

Figure 20: Dimensioning diagram

8.2 Electrical Characteristics

8.2.1 Power Supply

Table 16: Electrical characteristics

Operating Voltage ranges	5.5 V to 32 V DC, nominal at 13.2V DC.
Maximum current	500 mA Average at 5.5V. 2.5 A Peak at 5.5 V.

Note:

The Fastrack Supreme is permanently powered once the power supply is connected. The following table describes the consequences of over-voltage and under-voltage with the Fastrack Supreme.

Warning:

All the input voltages specification described in this Section are at the Fastrack Supreme input. While powering the Fastrack Supreme, take into account the input drop caused by the power cable. With the delivered cable, this input drop is around 700 mV at 5.5 V and 220 mV at 32V.

Table 17: Effects of power supply defect

If the voltage	then
falls below 5.5 V,	the GSM communication is not guaranteed.
is over 32 V (Transient peaks),	the Fastrack Supreme guarantees its own protection.
Is over 32 V (continuous overvoltage)	the protection of the Fastrack Supreme is done by the fuse (the supply voltage is disconnected).

The fuse is a 800 mA / 250 V FAST-ACTING 5*20mm. See Section 10 for recommended references.

The following table provides information on power consumption of the Fastrack Supreme, assuming an operating temperature of +25 °C and using a 3 V SIM card.

Fastrack Supreme User Guide

Technical Characteristics

8.2.2 Power Consumption

The following table provides information on power consumption of the Fastrack Supreme, assuming an operating temperature of +25 °C and using a 3 V SIM card.

Table 18: Power consumption in connected modes (1*)

Power Consumption in E-GSM 900/DCS 1800 MHz - GPRS class 10 (Serial Port ON)				GSM 850	E-GSM 900	DCS 1800	PCS 1900
GSM	I_{peak}	GSM850 / E-GSM900: During TX bursts @ PCL5 / PCL19 DCS1800 / PCS1900 : During TX bursts @ PCL0 / PCL15	@ 5.5V	2500 / 309	2338 / 328	2224 / 325	2210 / 334
			@ 13.2V	953 / 133	794 / 100	755 / 137	722 / 139
	I_{avg}	GSM850 / E-GSM900: Average @ PCL5 / PCL19 DCS1800 / PCS1900 : Average @ PCL0 / PCL15	@ 5.5V	267 / 98	237 / 100	227 / 100	226 / 100
			@ 13.2V	117 / 50	106 / 52	111 / 52	102 / 51
			@ 32V	52 / 23	47 / 23	45 / 23	45 / 23
	GPRS Class 2	I_{peak}	GSM850 / E-GSM900: During 1TX bursts @ PCL5(Gamma 3) / PCL19(Gamma 17) DCS1800 / PCS1900 : During 1TX bursts @ PCL0(Gamma 2) / PCL15(Gamma 18)	@ 5.5V	2485 / 288	2314 / 307	2195 / 307
@ 13.2V				943 / 124	784 / 132	737 / 139	724 / 131
I_{avg}		GSM850 / E-GSM900 : Average 1TX/1RX @PCL5(Gamma 3) / PCL19(Gamma 17) DCS1800 / PCS1900: Average 1TX/1RX @PCL0(Gamma 2) / PCL15(Gamma 18)	@ 5.5V	255 / 94	228 / 96	218 / 96	219 / 97
			@ 13.2V	112 / 48	102 / 50	99 / 50	99 / 51
			@ 32V	49 / 22	45 / 23	44 / 23	44 / 23
GPRS Class 10		I_{peak}	GSM850 / E-GSM900: During 2TX bursts @ PCL5(Gamma 3) / PCL19(Gamma 17) DCS1800 / PCS1900: During 2TX bursts @ PCL0(Gamma 2) / PCL15(Gamma 18)	@ 5.5V	2418 / 294	1269 / 315	2215 / 317
	@ 13.2V			950 / 125	790 / 135	750 / 142	733 / 131
	I_{avg}	GSM850 / E-GSM900 : Average 2TX/3RX @ PCL5 (Gamma 3) / PCL19(Gamma 17) DCS1800 / PCS1900: Average 2TX/3RX @ PCL0 (Gamma 2) / PCL15(Gamma 18)	@ 5.5V	459 / 126	396 / 129	375 / 129	377 / 130
			@ 13.2V	191 / 62	170 / 65	163 / 65	163 / 64
			@ 32V	84 / 29	75 / 30	71 / 29	71 / 30

Fastrack Supreme User Guide

Technical Characteristics

Power Consumption in E-GSM 900/DCS 1800 MHz - GPRS class 10 (Serial Port ON)				GSM 850	E-GSM 900	DCS 1800	PCS 1900
EGPRS Class 2	I_{peak}	GSM850 / E-GSM900: During 1TX bursts @ PCL8 (Gamma 6) / PCL19(Gamma 17)	@ 5.5V	2493 / 361	2334 / 391	2211 / 387	2225 / 389
		DCS1800 / PCS1900: During 1TX bursts @ PCL2 (Gamma 5) / PCL15(Gamma 18)	@ 13.2V	958 / 150	801 / 161	744 / 162	743 / 158
	I_{avg}	GSM850 / E-GSM900 : Average 1TX/1RX @ PCL8 (Gamma 6) / PCL 19(Gamma 17) DCS1800 / PCS1900: Average 1TX/1RX @ PCL2 (Gamma 5) / PCL 15(Gamma 18)	@ 5.5V	170 / 100	163 / 102	173 / 103	176 / 103
			@ 13.2V	79 / 51	77 / 53	82 / 53	82 / 52
			@ 32V	36 / 23	34 / 24	36 / 24	36 / 24
	EGPRS Class 10	I_{peak}	GSM850 / E-GSM900: During 2TX bursts @ PCL8 (Gamma 6) / PCL 19(Gamma 17)	@ 5.5V	2492 / 367	2328 / 395	2206 / 390
DCS1800 / PCS1900: During 2TX bursts @ PCL2 (Gamma 5) / PCL 15(Gamma 18)			@ 13.2V	961 / 568	802 / 162	735 / 166	743 / 160
I_{avg}		GSM 850 / E-GSM900 : Average 2TX/3RX @ PCL8 (Gamma 6) / PCL 19(Gamma 17) DCS1800 / PCS1900: Average 2TX/3RX @ PCL2 (Gamma 5) / PCL 15(Gamma 18)	@ 5.5V	280 / 137	264 / 142	287 / 142	295 / 143
			@ 13.2V	125 / 73	119 / 69	129 / 70	130 / 70
			@ 32V	55 / 31	52 / 32	58 / 32	57 / 32

Table 19: Power consumption in non-connected modes(1*)

Non-connected mode	Serial Port status	Voltage	Current (mA)
I_{avg} in Fast Idle mode Page 9 (2*)	ON	@ 5.5V	34.3
		@ 13.2V	17.8
		@ 32V	9.2
	OFF	@ 5.5V	16.5
		@ 13.2V	9.4
		@ 32V	5.2
I_{avg} in Slow Idle mode Page 9 (3*)	ON	@ 5.5V	23.5
		@ 13.2V	13.4
		@ 32V	6.9
	OFF	@ 5.5V	5.1
		@ 13.2V	3.5
		@ 32V	2.8

Fastrack Supreme User Guide

Technical Characteristics

Non-connected mode	Serial Port status	Voltage	Current (mA)
I_{avg} in Fast Standby mode (4*)	ON	@ 5.5V	51.4
		@ 13.2V	25.9
		@ 32V	13.2
	OFF	@ 5.5V	33.9
		@ 13.2V	18.0
		@ 32V	9.3
I_{avg} in Slow Standby mode (with FLASH LED activated) (4*)	ON	@ 5.5V	24.2
		@ 13.2V	13.8
		@ 32V	7.0
	OFF	@ 5.5V	6.6
		@ 13.2V	3.9
		@ 32V	3.0
I_{avg} in Slow Standby mode (with FLASH LED deactivated) (4*)	ON	@ 5.5V	22.8
		@ 13.2V	13.0
		@ 32V	6.7
	OFF	@ 5.5V	4.1
		@ 13.2V	3.1
		@ 32V	2.7

(1*):The power consumption might vary by 5 % over the whole operating temperature range (-20 °C to +55 °C).

(2*): In this Mode, the RF function is active and the Fastrack Supreme synchronized with the network, but there is no communication.

(3*): In this Mode, the RF function is disabled, but regularly activated to keep the synchronization with the network. This Mode works only when the DTE send AT command to shut down the serial link by software approach (DTE turns DTR in inactive state).

(4*): In this Mode, the RF function is disabled, and there is no synchronization with the network.

Fastrack Supreme User Guide

Technical Characteristics

8.2.3 Audio Interface

The audio interface is available through the Sub HD 15-pin connector.

Table 20: Audio parameters characteristics

Audio parameters	Min	Typ	Max	Unit	Comments
Microphone input current @2 V/2 k Ω		0.5		mA	
Absolute microphone input voltage			100	mVpp	AC voltage
Speaker output current 150 Ω //1 nF		16		mA	
Absolute speaker impedance	32	50		Ω	
Impedance of the speaker amplifier output in differential mode			1	Ω	+/-10 %

Table 21: Microphone inputs internal audio filter characteristics

Frequency	Gain
0-150 Hz	< -22 dB
150-180 Hz	< -11 dB
180-200 Hz	< -3 dB
200-3700 Hz	0 dB
>4000 Hz	< -60 dB

Table 22: Recommended characteristics for the microphone:

Feature	Value
Type	Electret 2 V / 0.5 mA
Impedance	Z = 2 k Ω
Sensitivity	-40 dB to -50 dB
SNR	> 50 dB
Frequency response	compatible with the GSM specifications

Fastrack Supreme User Guide
Technical Characteristics

Table 23: Recommended characteristics for the speaker:

Feature	Value
Type	10 mW, electro-magnetic
Impedance	Z = 32 to 50 Ω
Sensitivity	110 dB SPL min. (0 dB = 20 μ Pa)
Frequency response	compatible with the GSM specifications

8.2.4 General Purpose Input/Output

Both GPIO21 and GPIO25 may be interfaced with a component that comply with 3 Volts CMOS levels.

Table 24: Operating conditions

Parameter	I/O type	Min	Typ	Max	Condition
V _{IL}	CMOS			0.84 V	
V _{IH}	CMOS	1.96 V			
V _{OL}	CMOS			0.4 V	I _{OL} = -4 mA
V _{OH}	CMOS	2.4 V			I _{OH} = 4 mA
I _{OH}				4mA	
I _{OL}				-4mA	

Clamping diodes are present on I/O pads.

8.2.5 SIM Interface

Table 25: SIM card characteristics

SIM card	1.8V / 3 V
----------	------------

8.2.6 RESET Signal

Table 26: Electrical characteristics

Parameter	Min	Typ	Max	Unit
Input Impedance (R)*		330K		k Ω
Input Impedance (C)		10n		nF

*Internal pull-up

Fastrack Supreme User Guide
Technical Characteristics

Table 27: Operating conditions

Parameter	Minimum	Typ	Maximum	Unit
~RESET time (Rt) ¹	200			μ s
~RESET time (Rt) ² at power up only	20	40	100	ms
Cancellation time (Ct)		34		ms
V _H	0.57			V
V _{IL}	0		0.57	V
V _{IH}	1.33			V

* V_H: Hysterisis Voltage

1 This reset time is the minimum to be carried out on the ~RESET signal when the power supply is already stabilized.

2 This reset time is internally carried out by the Wireless CPU[®] power supply supervisor only when the Wireless CPU[®] power supplies are powered ON.

8.2.7 RF Characteristics

8.2.7.1 Frequency Ranges

Table 28: Frequency ranges

Characteristic	GSM 850	E-GSM 900	DCS 1800	PCS 1900
Frequency TX	824 to 849 MHz	880 to 915 MHz	1710 to 1785 MHz	1850 to 1910 MHz
Frequency RX	869 to 894 MHz	925 to 960 MHz	1805 to 1880 MHz	1930 to 1990 MHz

Fastrack Supreme User Guide

Technical Characteristics

8.2.7.2 RF Performances

RF performances are compliant with the ETSI recommendation GSM 05.05.
The RF performances for receiver and transmitter are given in the table below.

Table 29: Receiver and transmitter RF performances

Receiver	
E-GSM900/GSM850 Reference Sensitivity	-104 dBm Static & TUHigh
DCS1800/PCS1900 Reference Sensitivity	-102 dBm Static & TUHigh
Selectivity @ 200 kHz	> +9 dBc
Selectivity @ 400 kHz	> +41 dBc
Linear dynamic range	63 dB
Co-channel rejection	>= 9 dBc
Transmitter	
Maximum output power (E-GSM 900/GSM850) at ambient temperature	33 dBm +/- 2 dB
Maximum output power (DCS1800/PCS1900) at ambient temperature	30 dBm +/- 2 dB
Minimum output power (E-GSM 900/GSM850) at ambient temperature	5 dBm +/- 5 dB
Minimum output power (DCS1800/PCS1900) at ambient temperature	0 dBm +/- 5 dB

8.2.7.3 External Antenna

The external antenna is connected to the Fastrack Supreme via the SMA connector.
The external antenna must fulfill the characteristics listed in the table below.

Table 30: External antenna characteristics

Antenna frequency range	Quad-band GSM 850/GSM900/DCS1800/PCS1900 MHz
Impedance	50 Ohms nominal
DC impedance	0 Ohm
Gain (antenna + cable)	0 dBi
VSWR (antenna + cable)	2

Note: Refer to Section 10 for recommended antenna.

8.3 Environmental Characteristics

The Fastrack Supreme Plug & Play is compliant with the following operating class. To ensure the proper operation of the Fastrack Supreme, the temperature of the environment must be within a specific range as described in the table below.

Table 31: Ranges of temperature

No IESM Current Drain	
Conditions	Temperature Range
Operating / Class A	-20°C ~ +55°C
Operating / Class B ^{Note1}	-30°C ~ +75°C
Operating / Class C ^{Note1}	-30°C ~ +85°C
Storage ^{Note1}	-40°C ~ +85°C

Note1: Please refer to the Remark in Section 7.9 for RTC battery related issue.

Function Status Classification:

Class A:

The Fastrack Supreme remains fully functional, meeting GSM performance criteria in accordance with ETSI requirements, across the specified temperature range.

Class B:

The Fastrack Supreme remains fully functional, across the specified temperature range. Some GSM parameters may occasionally deviate from the ETSI/PTCRB specified requirements and this deviation does not affect the ability of the Fastrack Supreme to connect to the cellular network and function fully, as it does within the Class A range.

Class C:

The functional requirements will not be fulfilled during external influence, but will return to fully functional automatically, after the external influence has been removed.

Fastrack Supreme User Guide

Technical Characteristics

The detailed climatic and mechanics standard environmental constraints applicable to the Fastrack Supreme are listed in the table below:

Table 32: Environmental standard constraints

Environmental Tests (IEC TR 60721-4)		Environmental Classes (IEC 60721-3)			
Tests	Standards	Storage (IEC 60721-3-1) Class IE13	Transportation (IEC 60721-3-2) Class IE23	Operation	
				Stationary (IEC 60721-3-3) Class IE35	Non-Stationary (IEC 60721-3-7) Class IE73
Cold	IEC 60068-2-1 : Ab/Ad	-25°C, 16 h	-40°C, 16 h	-5°C, 16 h	-5°C, 16 h
Dry heat	IEC 60068-2-2 : Bb/Bd	+70°C, 16 h	+70°C, 16 h	+55°C, 16 h	+55°C, 16 h
Change of temperature	IEC 60068-2-14 : Na/Nb	-33°C to ambient 2 cycles, t1=3 h 1 °C.min ⁻¹	-40°C to ambient 5 cycles, t1=3 h t2<3 min	-5°C to ambient 2 cycles, t1=3 h 0,5 °C.min ⁻¹	-5°C to ambient 5 cycles, t1=3 h t2<3 min
Damp heat	IEC 60068-2-56 : Cb	+30°C, 93% RH 96 h	+40°C, 93% RH 96 h minimum	+30°C, 93% RH, 96 h	+30°C, 93% RH, 96 h
Damp heat, cyclic	60068-2-30 : Db Variant 1 or 2	+40°C, 90% to 100% RH One cycle Variant 2	+55°C, 90% to 100% RH Two cycles Variant 2	+30°C, 90% to 100% RH Two cycles Variant 2	+40°C, 90% to 100% RH Two cycles Variant 1
Vibration (sinusoidal)	IEC 60068-2-6 : Fc	1-200 Hz 2 m.s ⁻² 0,75 mm 3 axes 10 sweep cycles	1-500 Hz 10 m.s ⁻² 3,5 mm 3 axes 10 sweep cycles	1-150 Hz 2 m.s ⁻² 0,75 mm 3 axes 5 sweep cycles	1-500 Hz 10 m.s ⁻² 3,5 mm 3 axes 10 sweep cycles
Vibration (random)	IEC 60068-2-64 : Fh	-	10-100 Hz / 1,0 m ² .s ⁻³ 100-200 Hz / -3 dB.octave ⁻¹ 200-2000 Hz / 0,5 m ² .s ⁻³ 3 axes 30 min	-	-
Shock (half-sine)	IEC 60068-2-27 : Ea	-	-	50 m.s ⁻² 6 ms 3 shocks 6 directions	150 m.s ⁻² 11 ms 3 shocks 6 directions
Bump	IEC 60068-2-29 : Eb	-	250 m.s ⁻² 6 ms 50 bumps vertical direction	-	-
Free fall	ISO 4180-2	-	Two falls in each specified attitude	-	2 falls in each specified attitude 0,025 m (<1kg)
Drop and topple	IEC 60068-2-31 : Ec	-	One drop on relevant corner One topple about each bottom edge	-	One drop on each relevant corner One topple on each of 4 bottom edges

Fastrack Supreme User Guide

Technical Characteristics

Notes:

Short description of Class IE13 (For more information see standard IEC 60721-3-1)

"Locations without controlled temperature and humidity, where heating may be used to raise low temperatures, locations in buildings providing minimal protection against daily variations of external climate, prone to receiving rainfall from carrying wind".

Short description of Class IE23 (For more information, see standard IEC 60721-3-2)

"Transportation in unventilated compartments and in conditions without protection against bad weather, in all sorts of trucks and trailers in areas of well developed road network, in trains equipped with buffers specially designed to reduce shocks and by boat".

Short description of Class IE35 (For more information see standard IEC 60721-3-3)

"Locations with no control on heat or humidity where heating may be used to raise low temperatures, to places inside a building to avoid extremely high temperatures, to places such as hallways, building staircases, cellars, certain workshops, equipment stations without surveillance".

Short description of Class IE73 (For more information see standard IEC 60721-3-7)

"Transfer to places where neither temperature nor humidity are controlled but where heating may be used to raise low temperatures, to places exposed to water droplets, products can be subjected to ice formation, these conditions are found in hallways and building staircases, garages, certain workshops, factory building and places for industrial processes and hardware stations without surveillance".

Warning: The specification in the above table applies to the Fastrack Supreme product only. Customers are advised to verify that the environmental specification of the SIM Card used is compliant with the Fastrack Supreme environmental specifications. Any application must be qualified by the customer with the SIM Card in storage, transportation and operation.

The use of standard SIM cards may drastically reduce the environmental conditions in which the Product can be used. These cards are particularly sensible to humidity and temperature changes. These conditions may produce oxidation of the SIM card metallic layers and cause, in the long term, electrical discontinuities. This is particularly true in left alone applications, where no frequent extraction/insertion of the SIM card is performed.

In case of mobility when the application is moved through different environments with temperature variations, some condensation may appear. These events have a negative impact on the SIM and may favor oxidation.

If the use of standard SIM card, with exposition to the environmental conditions described above, can not be avoided, special care must be taken in the integration of the final application in order to minimize the impact of these conditions. The solutions that may be proposed are:

- Lubrication of the SIM card to protect the SIM Contact from oxidation.
- Putting the Fastrack Supreme Plug & Play in a waterproof enclosure with desiccant bags.

Fastrack Supreme User Guide

Technical Characteristics

Lubrication of the SIM card had been tested by Wavecom (using Tutela Fluid 43EM from MOLYDUVAL) and gives very good results.

If waterproof enclosure with a desiccant solution is used, check with your desiccant retailer the quantity that must be used according to the enclosure dimensions. Ensure humidity has been removed before sealing the enclosure.

Any solution selected must be qualified by the customer on the final application.

To minimize oxidation problem on the SIM card, its manipulation must be done with the greatest precautions. In particular, the metallic contacts of the card must never be touched with bare fingers or any matter which may contain polluted materials liable to produce oxidation (such as, e.g. substances including chlorine). In case a cleaning of the Card is necessary, a dry cloth must be used (never use any chemical substance).

8.4 Conformity

The complete product complies with the essential requirements of article 3 of R&TTE 1999/5/EC Directive and satisfied the following standards:

Domain	Applicable standard
Safety standard	EN 60950 (ed.1999)
Efficient use of the radio frequency spectrum	EN 301 419-(v 4.1.1) EN 301 511 (V 9.0.2)
EMC	EN 301 489-1 (edition 2002) EN 301 489-7 (edition 2002)
Global Certification Forum – Certification Criteria	GCF-CC V3.26.0
PTCRB	NAPRD.03 V3.11.0
FCC	FCC Part 15 FCC Part 22, 24
IC	RSS-132 Issue 2 RSS-133 Issue 3

8.5 Protections

8.5.1 Power Supply

The Fastrack Supreme is protected by a 800 mA / 250 V fuse directly bonded on the power supply cable.

The model of fuse used is: **FSD 800 mA / 250 V FAST-ACTING.**

8.5.2 Overvoltage

The Fastrack Supreme is protected against voltage over +32 V.

When input voltages exceed +32 V, the supply voltage is disconnected in order to protect the internal electronic components from an overvoltage.

8.5.3 Electrostatic Discharge

The Fastrack Supreme withstands ESD according to IEC 1000-4-2 requirements for all accessible parts of the Fastrack Supreme except the RF part:

- 8 kV of air discharge,
- 4 kV of contact discharge.

8.5.4 Miscellaneous

Filtering guarantees:

- EMI/RFI protection in input and output,
- Signal smoothing.

9 Safety Recommendations

9.1 General Safety

It is important to follow any special regulations regarding the use of radio equipment due in particular to the possibility of radio frequency (RF) interference. Please follow the safety advice given below carefully.

Switch OFF your Wireless CPU®:

- When in an aircraft. The use of cellular telephones in an aircraft may endanger the operation of the aircraft, disrupt the cellular network and is illegal. Failure to observe this instruction may lead to suspension or denial of cellular telephone services to the offender, or legal action or both,
- When at a refueling point,
- When in any area with a potentially explosive atmosphere which could cause an explosion or fire,
- In hospitals and any other place where medical equipment may be in use.

Respect restrictions on the use of radio equipment in:

- Fuel depots,
- Chemical plants,
- Places where blasting operations are in progress,
- Any other area where signalization reminds that the use of cellular telephone is forbidden or dangerous.
- Any other area where you would normally be advised to turn off your vehicle engine.

There may be a hazard associated with the operation of your Fastrack Supreme Plug & Play close to inadequately protected personal medical devices such as hearing aids and pacemakers. Consult the manufacturers of the medical device to determine if it is adequately protected.

Operation of your Fastrack Supreme Plug & Play close to other electronic equipment may also cause interference if the equipment is inadequately protected. Observe any warning signs and manufacturers' recommendations.

The Fastrack Supreme Plug & Play is designed for and intended to be used in "**fixed**" and "**mobile**" applications:

- "**Fixed**" means that the device is physically secured at one location and is not able to be easily moved to another location.
- "**Mobile**" means that the device is designed to be used in other than fixed locations and generally in such a way that a separation distance of at least 20 cm (8 inches) is normally maintained between the transmitter's antenna and the body of the user or nearby persons.

Fastrack Supreme User Guide

Safety Recommendations

The Fastrack Supreme Plug & Play is not designed for and intended to be used in portable applications (within 20 cm or 8 inches of the body of the user) and such uses are strictly prohibited.

9.2 Vehicle Safety

Do not use your Fastrack Supreme Plug & Play while driving, unless equipped with a correctly installed vehicle kit allowing 'Hands-Free' Operation.

Respect national regulations on the use of cellular telephones in vehicles. Road safety always comes first.

If incorrectly installed in a vehicle, the operation of Fastrack Supreme Plug & Play telephone could interfere with the correct functioning of vehicle electronics. To avoid such problems, make sure that the installation has been performed by a qualified personnel. Verification of the protection of vehicle electronics should form part of the installation.

The use of an alert device to operate a vehicle's lights or horn on public roads is not permitted.

9.3 Care and Maintenance

Your Fastrack Supreme Plug & Play is the product of advanced engineering, design and craftsmanship and should be treated with care. The suggestion below will help you to enjoy this product for many years.

Do not expose the Fastrack Supreme Plug & Play to any extreme environment where the temperature or humidity is high.

Do not use or store the Fastrack Supreme Plug & Play in dusty or dirty areas. Its moving parts (SIM holder for example) can be damaged.

Do not attempt to disassemble the Wireless CPU®. There are no user serviceable parts inside.

Do not expose the Fastrack Supreme Plug & Play to water, rain or spilt beverages. It is not waterproof.

Do not abuse your Fastrack Supreme Plug & Play by dropping, knocking, or violently shaking it. Rough handling can damage it.

Do not place the Fastrack Supreme Plug & Play alongside computer discs, credit or travel cards or other magnetic media. The information contained on discs or cards may be affected by the Wireless CPU®.

The use of third party equipment or accessories, not made or authorized by Wavecom may invalidate the warranty of the Wireless CPU®.

Do contact an authorized Service Center in the unlikely event of a fault in the Wireless CPU®.

9.4 Your Responsibility

This Fastrack Supreme Plug & Play is under your responsibility. Please treat it with care respecting all local regulations. It is not a toy. Therefore, keep it in a safe place at all times and out of the reach of children.

Try to remember your Unlock and PIN codes. Become familiar with and use the security features to block unauthorized use and theft.

10 Recommended Accessories

Accessories recommended by Wavecom for the Fastrack Supreme are given in the table below.

Table 33: List of recommended accessories

Designation	Part number	Supplier
Quad-band antenna	1140.26	ALLGON
	MA112VX00	MAT Equipment
	MCA1890 MH/PB/SMA m	HIRSCHMANN
SMA/FME Antenna adaptor		PROCOM
Power adaptor (Europe)	EGSTDW P2 EF9W3 24W Out:12 V - 2A In: 100 to 240 V - 50/60 Hz - 550 mA Mounted with micro-fit connector	EGSTDW (for power adaptor) MOLEX (for micro-fit connector)*
Fuse	F800L250V	Shanghai Fullness
IESM GPS + USB	FSUE01	WAVECOM
IESM IO + USB	FSUE02	WAVECOM
IESM IO + USB + GPS	FSUE03	WAVECOM
IESM Ethernet	FSUE04	WAVECOM

* Information not available for this preliminary version.

Fastrack Supreme User Guide
Recommended Accessories

Table 34: Fastrack Supreme Family

Designation	Part number	Supplier
Fastrack Supreme 10	FSU001	WAVECOM
Fastrack Supreme 20	FSU002	WAVECOM
IESM GPS + USB	FSUE01	WAVECOM
IESM IO + USB	FSUE02	WAVECOM
IESM IO + USB + GPS	FSUE03	WAVECOM
IESM Ethernet	FSUE04	WAVECOM
FSU 10 IESM GPS+USB	FSUP01	WAVECOM
FSU 20 IESM GPS+USB	FSUP02	WAVECOM
FSU 10 IESM IO+USB	FSUP03	WAVECOM
FSU 20 IESM IO+USB	FSUP04	WAVECOM
FSU 10 IESM IO+USB+GPS	FSUP05	WAVECOM
FSU 20 IESM IO+USB+GPS	FSUP06	WAVECOM
FSU 10 IESM Ethernet	FSUP07	WAVECOM
FSU 20 IESM Ethernet	FSUP08	WAVECOM

11 Online Support

Wavecom provides an extensive range on online support which includes the following areas of Wavecom's wireless expertise:

- the latest version of this document
- new versions of our Operating System user guides
- comprehensive support for Open AT[®]
- regulatory certifications
- carrier certifications
- application notes

To gain access to this support, simply visit our web site at <http://www.wavecom.com/fastracksupreme> or click on the desire link in Page. Privileged access via user login is provided to Wavecom authorized distributors.

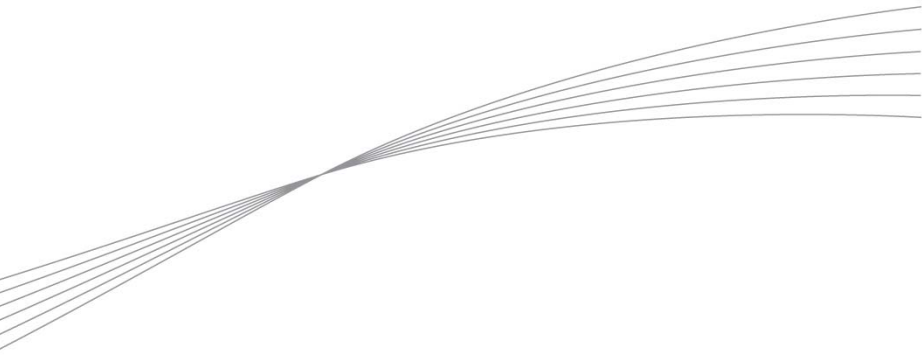

wavecom 

Make it wireless

WAVECOM S.A. - 3 esplanade du Foncet - 92442 Issy-les-Moulineaux Cedex - France - Tel: +33(0)1 46 29 08 00 - Fax: +33(0)1 46 29 08 08
Wavecom, Inc. - 4810 Eastgate Mall - Second Floor - San Diego, CA 92121 - USA - Tel: +1 858 362 0101 - Fax: +1 858 558 5485
WAVECOM Asia Pacific Ltd. - Unit 201-207, 2nd Floor, Bio-Informatics Centre - No.2 Science Park West Avenue - Hong Kong Science Park, Shatin
- New Territories, Hong Kong

www.wavecom.com