

THIS INFORMATION IS CONFIDENTIAL AND IS DISCLOSED TO YOU ON CONDITION THAT NO FURTHER DISCLOSURE IS MADE BY YOU TO OTHER THAN AMP PERSONNEL WITHOUT WRITTEN AUTHORIZATION FROM AMP (TAIWAN) LTD. DIMENSIONS IN MILLIMETERS. DO NOT SCALE PRINT.

METRIC
3RD ANGLE PROJECTION
NUMBER
C-1734350

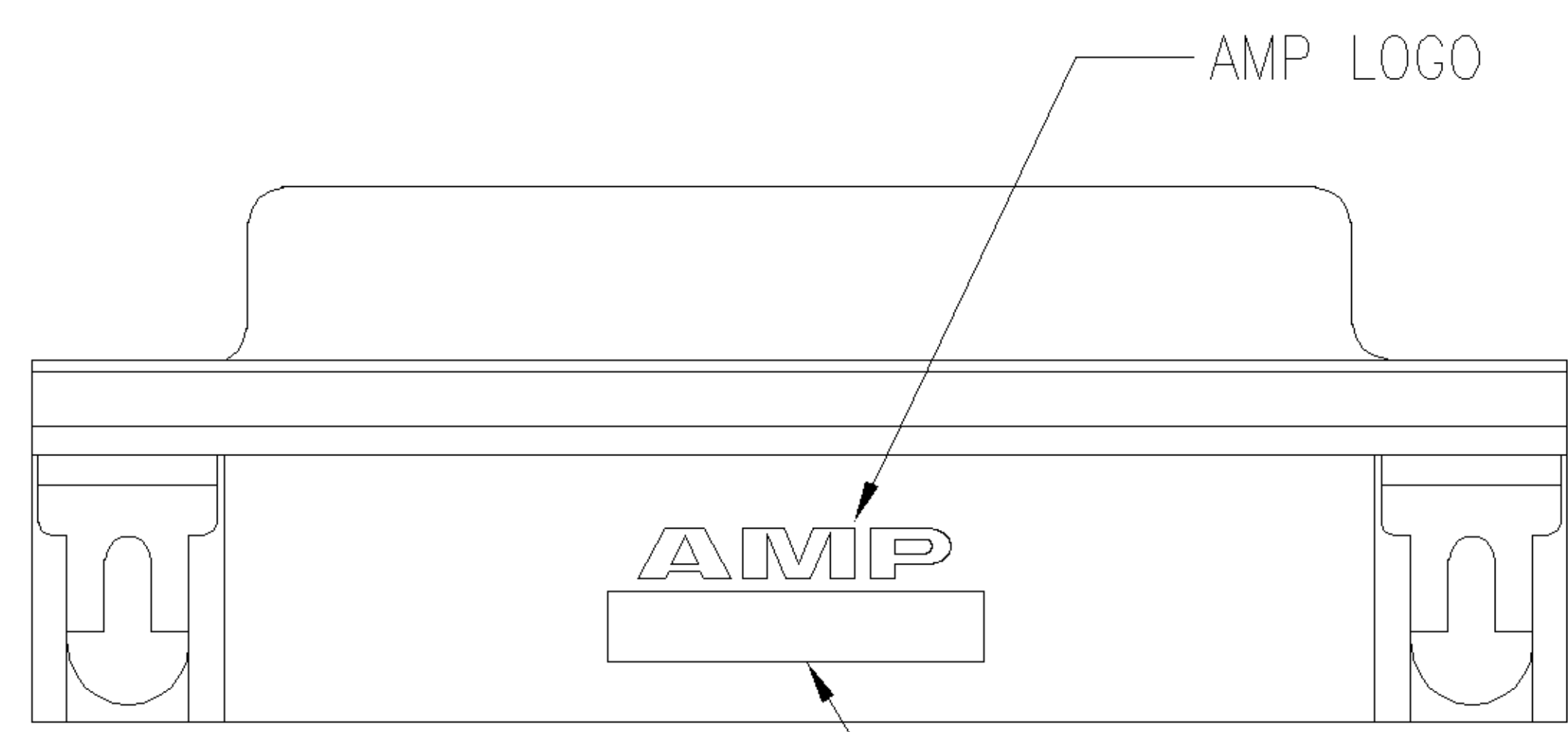
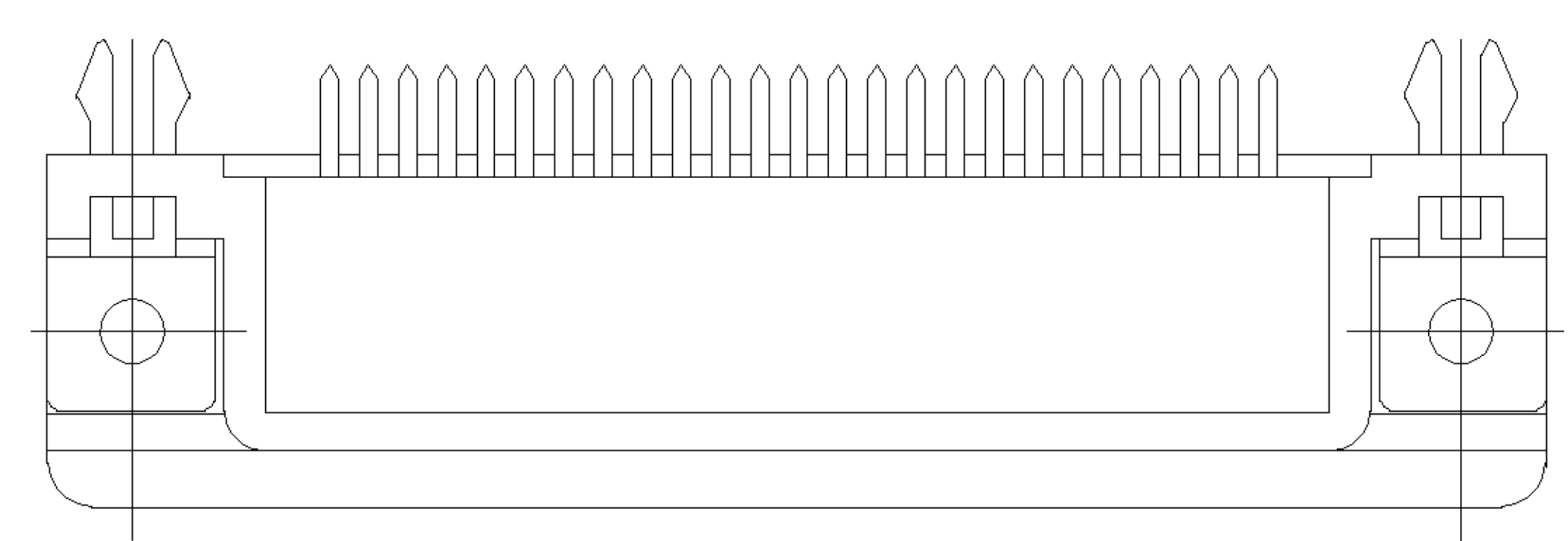
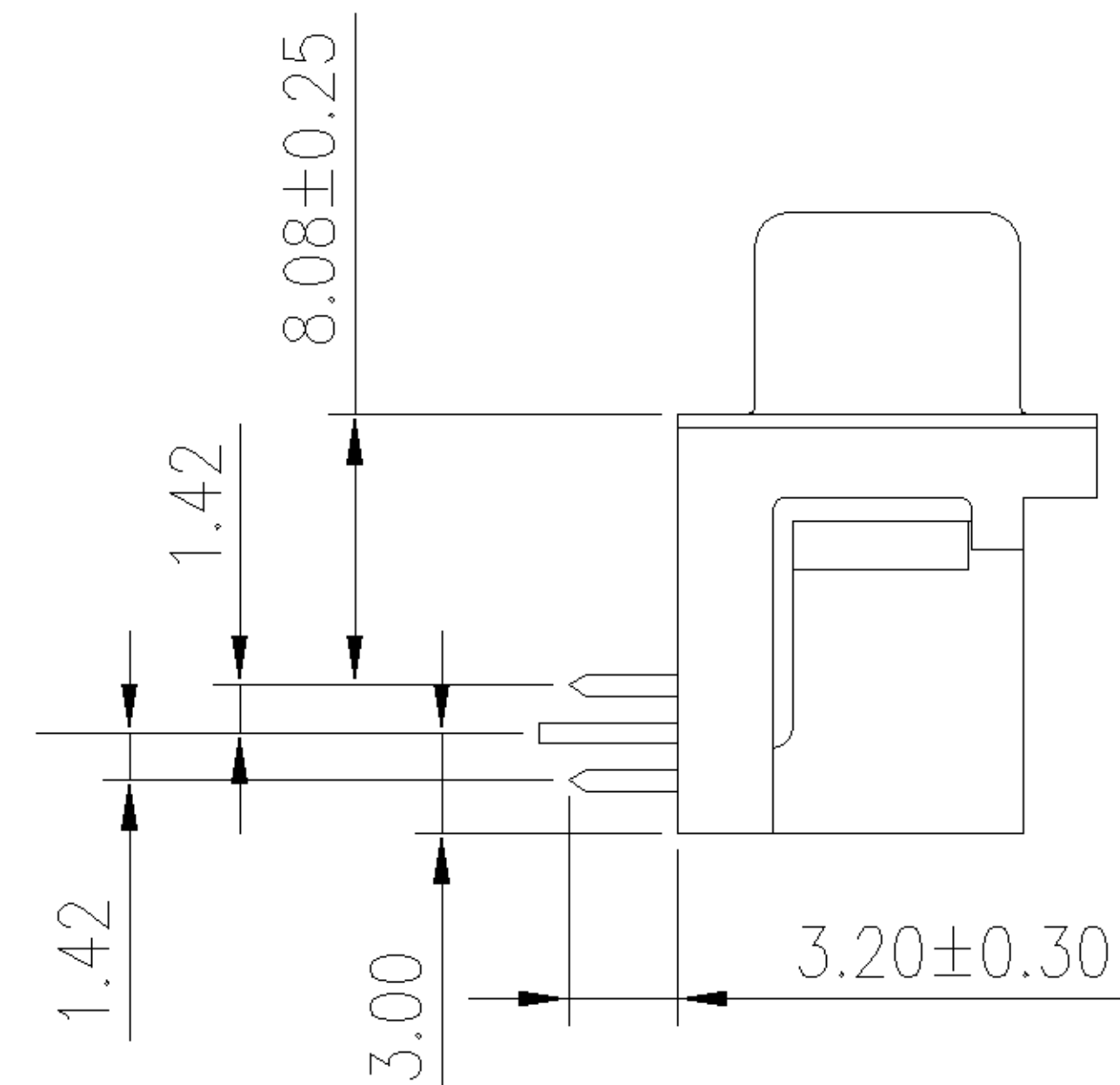
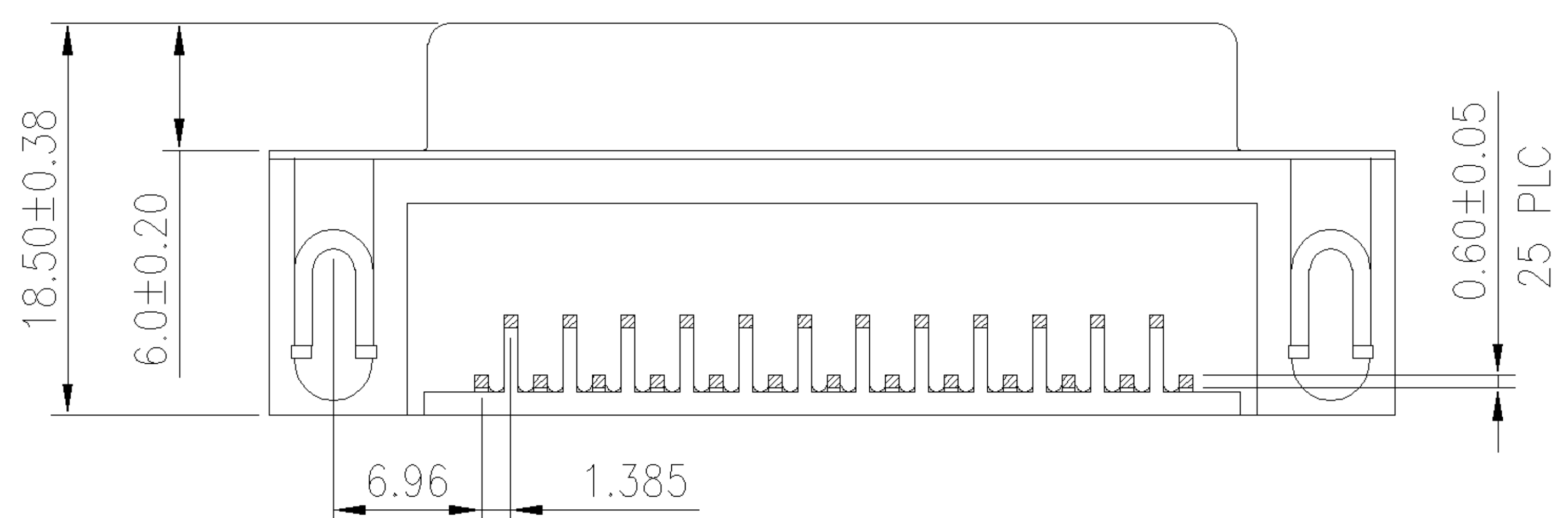
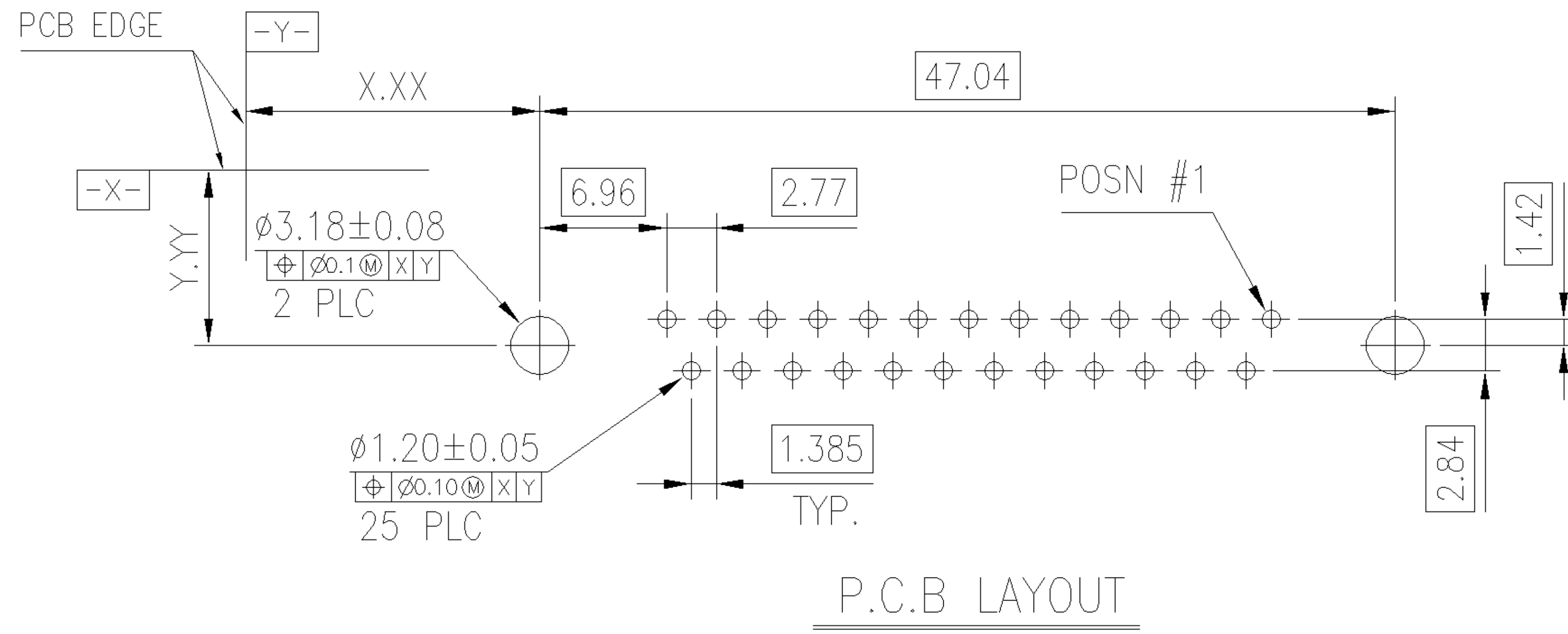
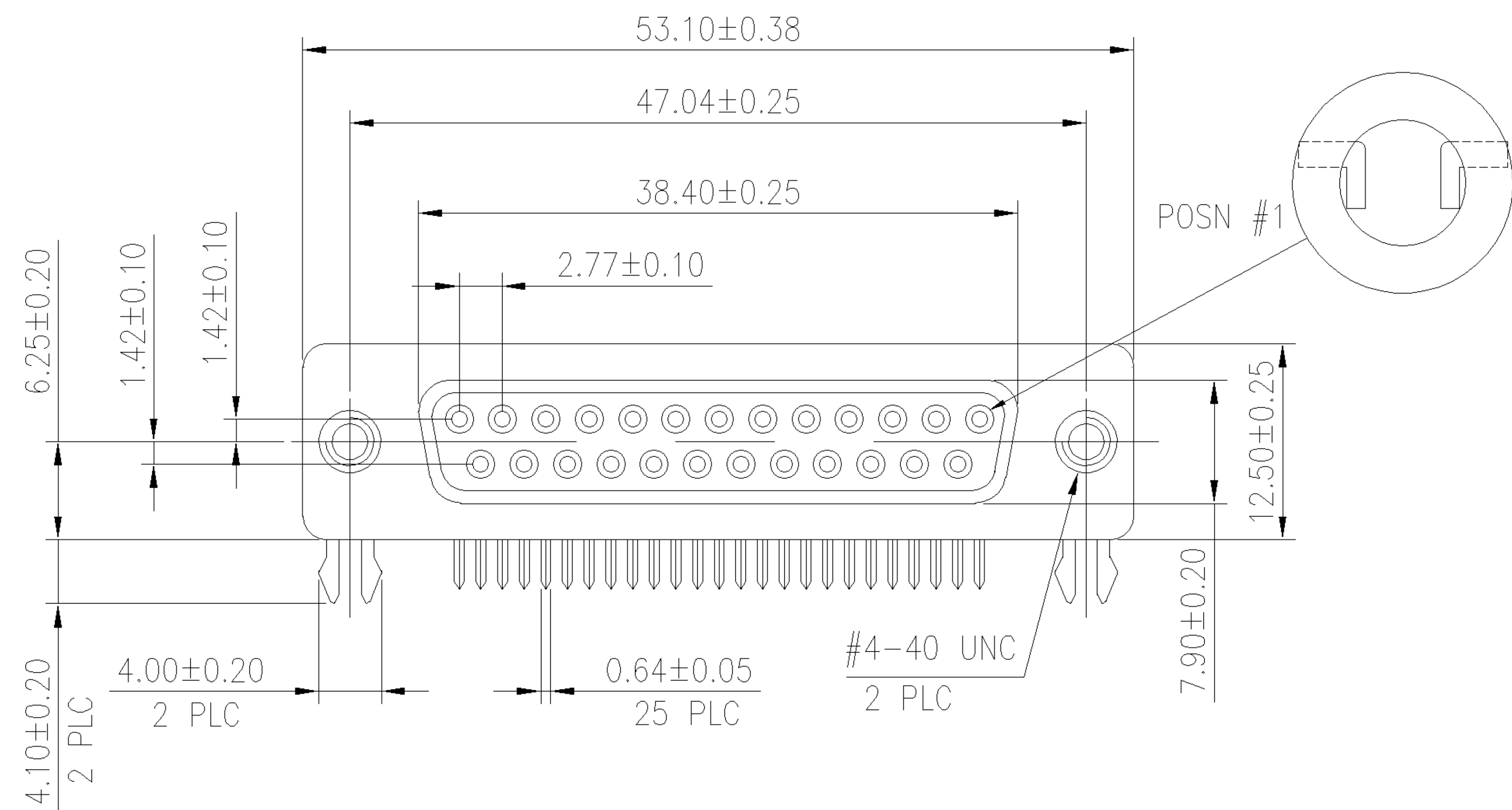

- NOTES:
- MATERIAL :
 - HOUSING: [TWO OPTIONAL]
 - PBT THERMOPLASTIC, UL 94V-0 RATED, BLACK
 - NY9T THERMOPLASTIC, UL 94V-0 RATED, BLACK
 - CONTACTS: PHOSPHOR BRONZE
 - SHELL: SPCC
 - BOARDLOCKS: BRASS.
 - RIVET: BRASS.
 - FINISH:
 - CONTACT: GOLD PLATING ON CONTACT AREA. 100u" MIN. MATTE TIN PLATING ON SOLDER TAIL AREA, 50u" MIN. NICKEL UNDERPLATING OVERALL,
 - BOARDLOCK: 100u" MIN MATTE TIN PLATING 50u" MIN NICKEL UNDERPLATING OVERALL,
 - SHELL: NICKEL PLATED
 - RIVET: NICKEL PLATING OVERALL
 - RECOMMENDED PCB THICKNESS: 1.6 mm
 - WAVE SOLDER CAPABLE TO 265°C PER TYCO SPEC. 109-202, CONDITION B.

NOTE 1.1	Δ	15u"	1-1734350-2
NOTE 1.1	Δ	GOLD-FLASH	1-1734350-1
NOTE 1.1	Δ	15u"	1734350-2
NOTE 1.1	Δ	GOLD-FLASH	1734350-1
HOUSE MATERIAL		CONTACT FINISH	PART NO.

TOLERANCES UNLESS OTHERWISE SPECIFIED: DWN		J. LEE 03-AUG-2005		tyco TYCO HOLDINGS (BERMUDA) VII LTD. TAIWAN BRANCH Electronics
0 PLC ±0.5 1 PLC ±0.3 2 PLC ±0.2 3 PLC ±0.15 ANGLES ±3°		S. HOU 03-AUG-2005		
MATERIAL		APVD W.J. KE 03-AUG-2005		NAME AMPLIMITE 8.08mm[0.318in] SERIES, R/A, RCPT, 25 POS
SEE NOTE		PRODUCT SPEC 108-57541		
FINISH		APPLICATION SPEC 501-57623		LDC DW SIZE A ₃ DRAWING NO C-1734350 REV □
LTR		WEIGHT 7.0 GRAM/PIECE		SCALE -- SHEET 1 OF 2

Q	FIRST RELEASED	--	JL	03-AUG-2005
LTR	REVISION RECORD	ECN	DWN CHK	DATE

CUSTOMER DRAWING

THIS INFORMATION IS CONFIDENTIAL AND IS DISCLOSED TO YOU ON CONDITION THAT NO FURTHER DISCLOSURE IS MADE BY YOU TO OTHER THAN AMP PERSONNEL WITHOUT WRITTEN AUTHORIZATION FROM AMP (TAIWAN) LTD. DIMENSIONS IN MILLIMETERS. DO NOT SCALE PRINT.

PRINT DW

METRIC

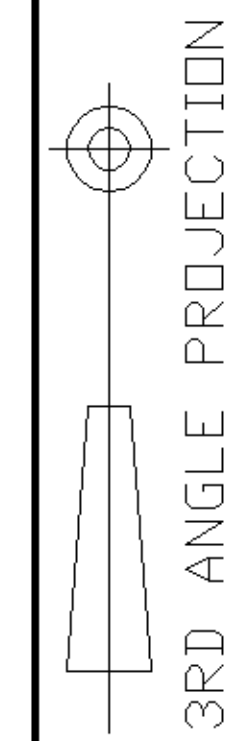

NUMBER C-1734350

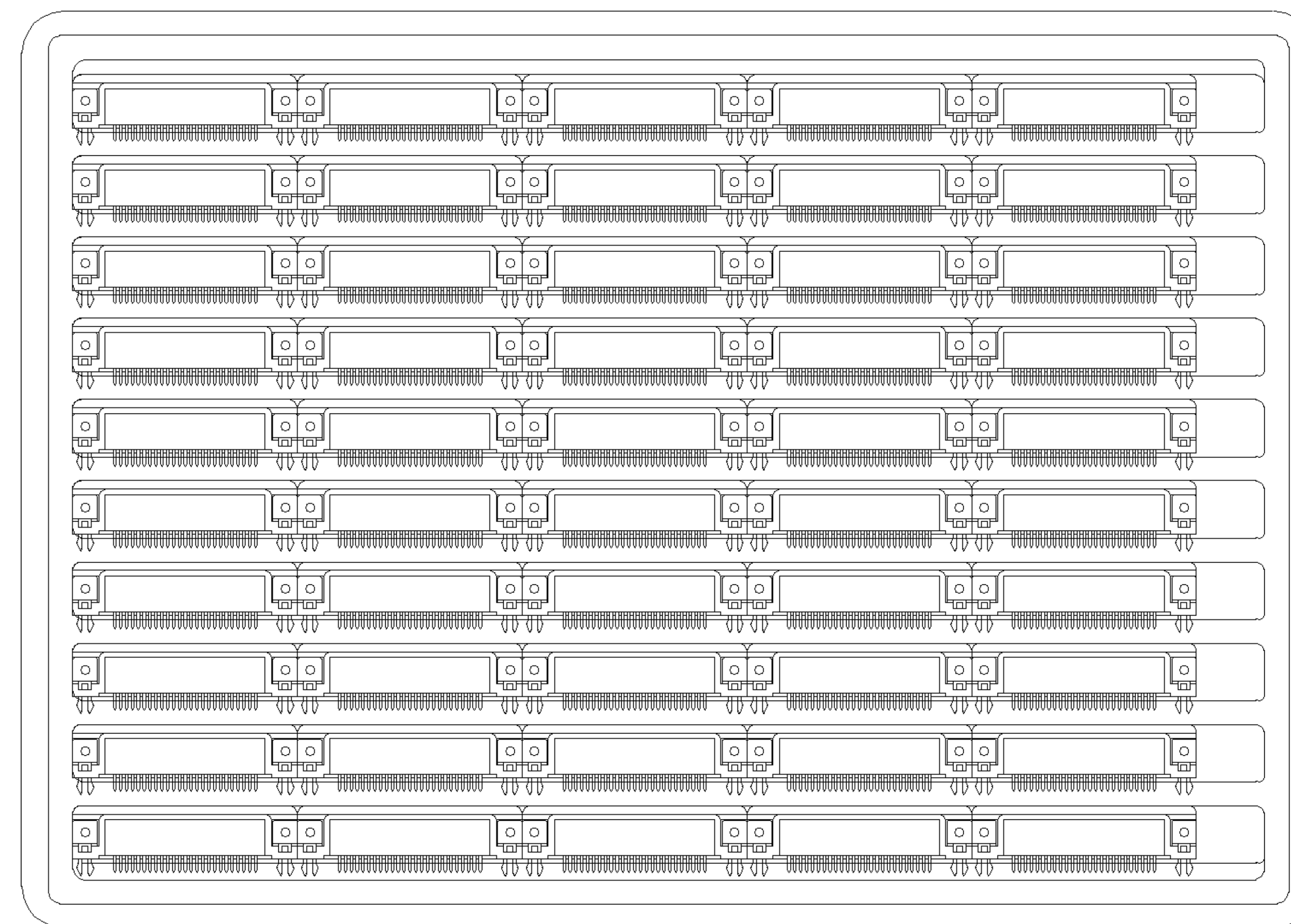
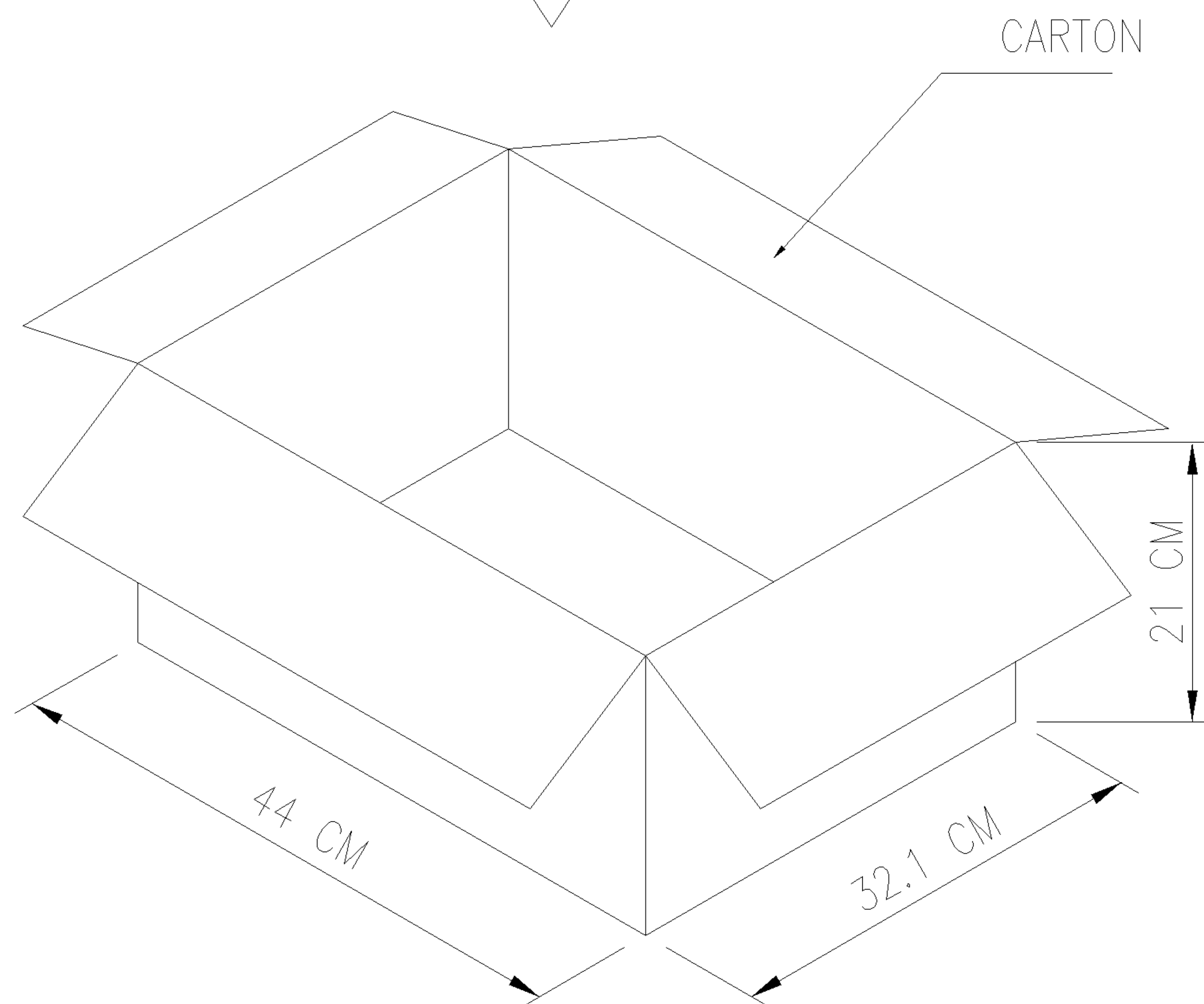
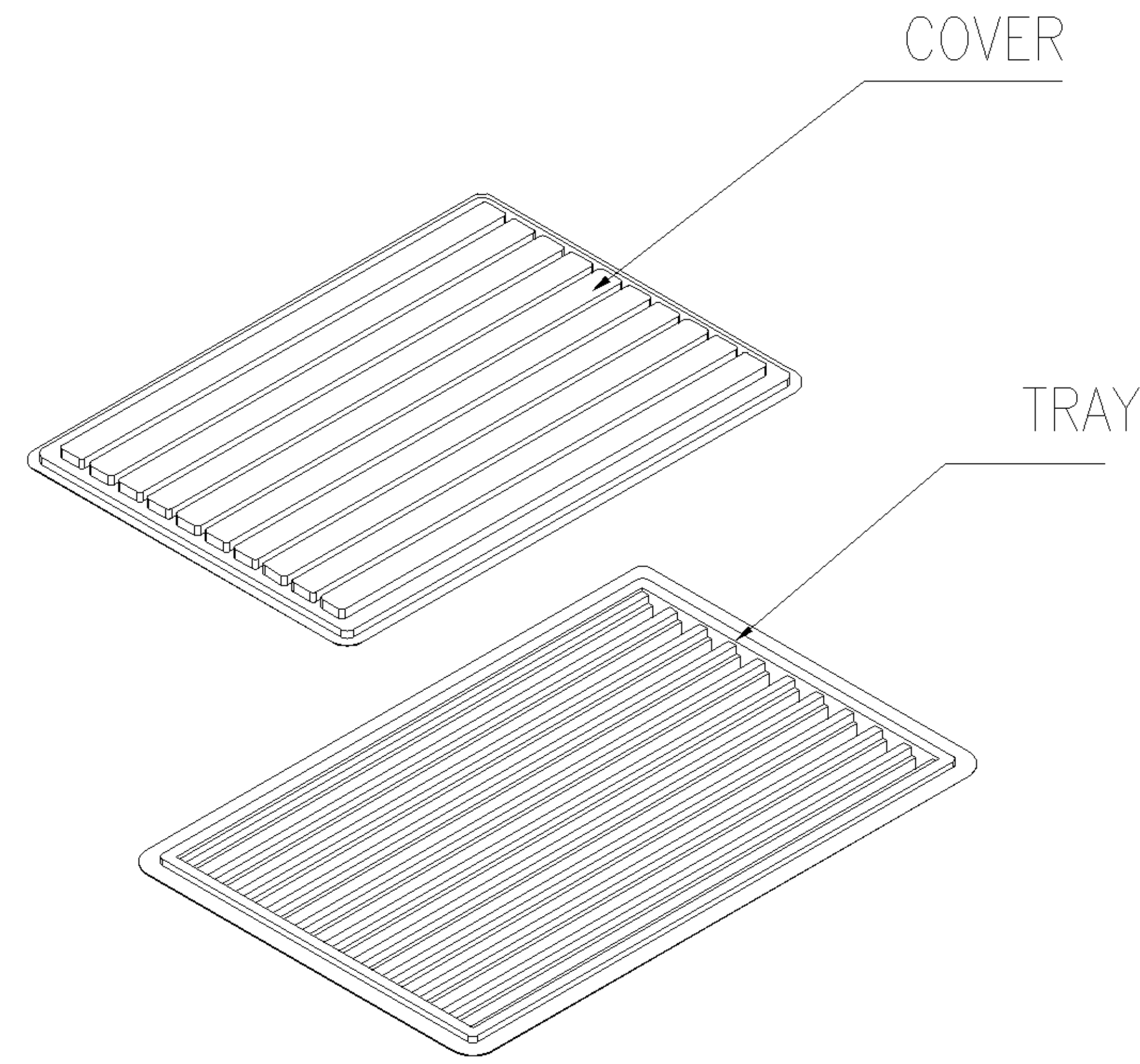
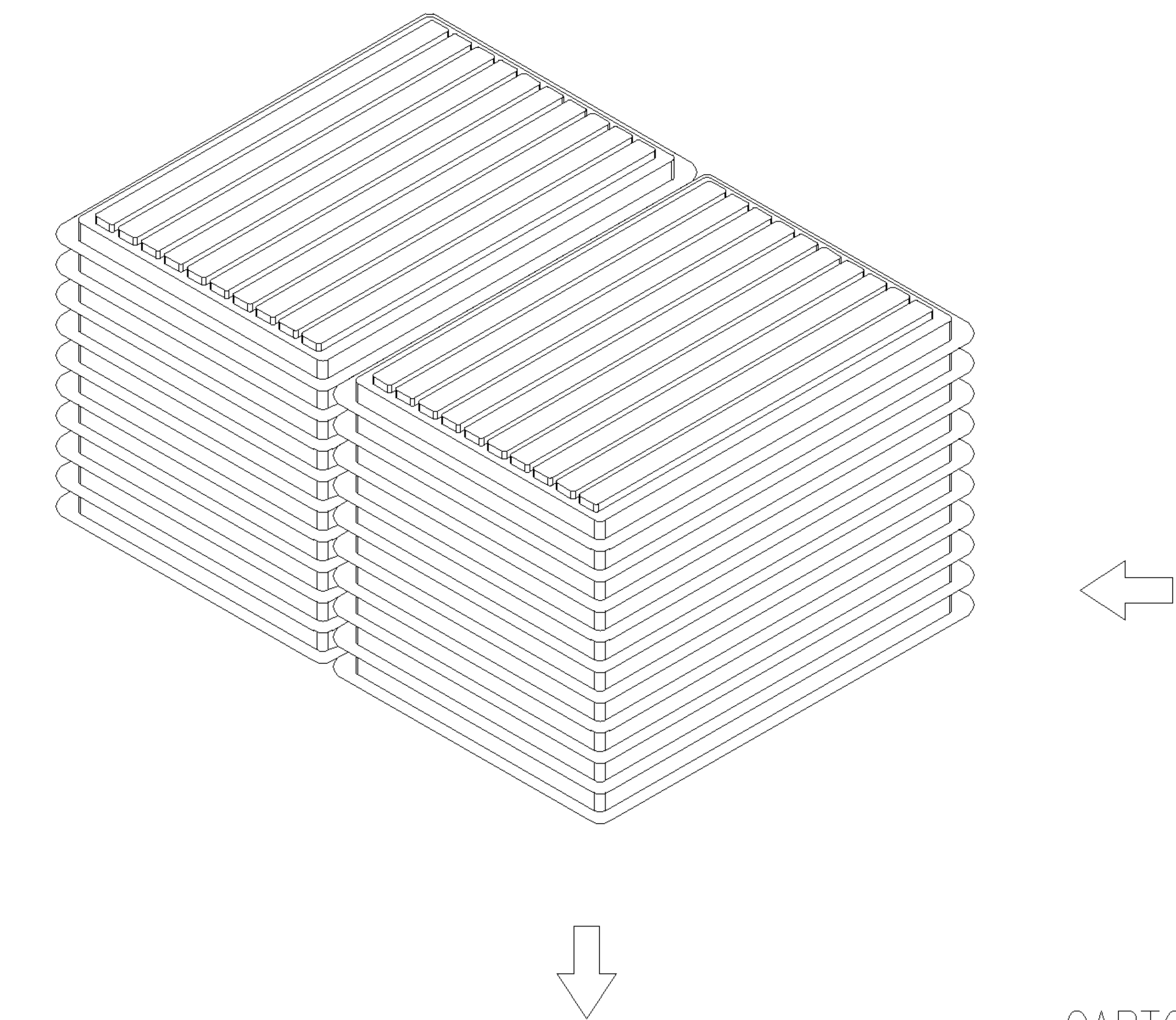

NOTES:

1. MATERIAL:
 - 1.1 TRAY: PVC
 - 1.2 SHIPPING CARTON: CORRUGATED FIBERBOARD
2. DIMENSION:
 - 2.1 TRAY: L=306, W=217, H=15
 - 2.2 SHIPPING CARTON: L=440, W=321, H=210
3. QUANTITY:
 - 3.1 PRIMARY PACKING: 50 PCS/TRAY
 - 3.2 THIRD PACKING: 20 TRAY/CARTON(1000PCS)
4. WEIGHT:
 - 4.1 NET WEIGHT: 7.0 Kg
 - 4.2 GROSS WEIGHT: 8.0 Kg

	SEE SHEET 1			
LTR	REVISION RECORD	ECN	DWN CHK	DATE

TOLERANCES UNLESS OTHERWISE SPECIFIED: DWN		J. LEE 03-AUG-2005		tyco TYCO HOLDINGS (BERMUDA)	
0 PLC ±		CHK		VII LTD. TAIWAN BRANCH	
1 PLC ±		S. HOU 03-AUG-2005		NAME	
2 PLC ±		W.J. KE 03-AUG-2005		AMPLIMITE	
3 PLC ±		APVD		8.08mm[0.318in] SERIES,	
ANGLES ±		PRODUCT SPEC		R/A, RCPT, 25 POS	
MATERIAL		--		LDC SIZE DRAWING NO REV	
SEE NOTE		APPLICATION SPEC		DW A ₃ C-1734350 □	
FINISH		WEIGHT		SCALE SHEET	
SEE NOTE		--		-- 2 OF 2	

CUSTOMER DRAWING