



Made in America

SmartLog X³™ Installation, Operation and Maintenance



Figure 1. SmartLog X³™

Description

The EMIT SmartLog X³™ is designed for fast, frequent, and accurate testing of ESD personnel grounding items. By touching the electrode button once the SmartLog X³™ tests the resistance path limits of the worn wrist strap and both worn ESD footwear independently within one second. Test results are electronically stored in the SmartLog X³™ and can easily be downloaded to a PC for logging records and evaluation. This product can be used as one of the tools to fulfill the ANSI ESD S20.20 section 7.3 "Compliance Verification Plan".

Paperless data can enhance operator accountability immediately identifying problems while reducing logging and auditing costs. There is no need to dedicate a computer. The SmartLog X³™ is a complete system including all required components. Operator identification can be accomplished by using the keypad, swiping a barcode card, or waving a proximity card (verify compatibility with the factory).

The SmartLog X³™ can test either single or dual-wire wrist straps; the split footplate design allows for individual footwear testing all in one test. If a resistance path is below or exceeds the set limits failure will be noted via audio and visual alarms. Passing tests can enable a relay for automated door openers. However, if the user desires to test the wrist strap and ESD footwear separately this can be accomplished. The wrist strap test is activated by inserting wrist strap banana plug into the designated banana jack. See Software Technical Bulletin TB-6565 for more information.

As many as 32 SmartLogs can be daisy-chained and connected to one computer allowing data to be collected to one central computer for all SmartLogs. The SmartLog X³™ can also be networked to a company's Intranet with the optional 50461 Ethernet Adapter. The SmartLog X³™ is calibrated to NIST traceable standards.

The SmartLog X³™'s default Wrist Strap test range is 1 - 10 megohms, and the default Footwear test range is 1 - 35 megohms. The ranges can be easily adjusted.

SmartLog X³™ Team Basic Software
Use the powerful versatile SmartLog X³™ Team Basic Software to collect and analyze records.

- 1) Specify tests and shifts for each employee in database
- 2) Auto or manual polling of data to computer
- 3) Auto archive and network data posting
- 4) Allow data to be saved and stored automatically
- 5) Data retrieval at selectable time intervals
- 6) Allow easy data analysis

See Technical Bulletin TB-6565 for more information.

ESD Association Information

"Compliance verification should be performed prior to each use (daily, shift change, etc.). The accumulation of insulative materials may increase the foot grounder system resistance. If foot grounders are worn outside the ESD protected area testing for functionality before reentry to the ESD protected area should be considered." ESD SP9.2 APPENDIX B - Foot Grounder Usage Guidance

"A log should be maintained which verifies that personnel have tested their personal grounding devices. (ANSI/ESD S20.20 section 6.2.2.2 Personnel Grounding Guidance)

ANSI/ESD S20.20 Table 1 Flooring-Footwear Systems Technical Requirements Recommended Range "less than 3.5 x 10E7 ohms measured per ANSI/ESD STM 97.1".

"Typical test programs recommend that wrist straps that are used daily should be tested daily. However, if the products that are being produced are of such value that knowledge of a continuous, reliable ground is needed, and then continuous monitoring should be considered or even required." (ESD Handbook ESD TR 20.20 section 5.3.2.4.4)

Carefully unpack the EMIT SmartLog X³™. The SmartLog X³™ comes ready to install without any changes to the clock's configuration.

If multiple SmartLogs are to be installed in a daisy-chain configuration refer to page 5 for instructions.

Please see the following technical bulletins for more information on the SmartLog X³™.

Number	Description
TB-6546	Ethernet Adapter
TB-6565	SmartLog X ³ ™ TEAM Basic Software

The EMIT SmartLog X³™ is available in six models:

Item	Description
50730	SmartLog X ³ ™ 120V, Software Included
50731	SmartLog X ³ ™ 120V, Hardware Only
50732	SmartLog X ³ ™ 220V, Software Included
50733	SmartLog X ³ ™ 220V, Hardware Only
50734	SmartLog X ³ ™ 220V CE, Software Included
50735	SmartLog X ³ ™ 220V CE, Hardware Only

Note: SmartLog X³™ is not designed to work in high humidity environments above 70 RH%.

Packaging

Items 50730, 50731, 50732, 50733

- 1 SmartLog X³™, SmartLog X³™ Wrist Strap / Footwear Tester, and Numeric Keypad on mounting plate
- 1 Dual Foot Plate
- 1 Stereo Cable for Dual Foot Plate
- 1 TEAM Basic Software Version 4.99.47 (50730 and 50732 only)
- 1 AC Adapter 12VDC 500mA center pos. (50730 and 50731 only)
- 1 DB9 Serial Adapter
- 1 25' RS-232 Non-inverted Data Cable
- 4 Mounting Anchors
- 4 Mounting Screws
- 1 Banana-to-Ring Terminal Cable
- 1 Shunt / Jumper

Items 50734, 50735

- 1 SmartLog X³™, SmartLog X³™ Wrist Strap / Footwear Tester, and Laser Barcode Scanner on mounting plate
- 1 Dual Foot Plate
- 1 Stereo Cable for Dual Foot Plate
- 1 TEAM Basic Software Version 4.99.47 (50734 only)
- 1 DB9 Serial Adapter
- 1 25' RS-232 Non-inverted Data Cable
- 4 Mounting Anchors
- 4 Mounting Screws

- 1 Banana-to-Ring Terminal Cable
- 1 Shunt / Jumper
- 1 Ferrite Bead

Features and Components



Figure 2. SmartLog X³™ features and components (Items 50730, 50731, 50732, 50733)

A. Numeric Keypad: Inputs numeric IDs.

B. Infrared Barcode Reader: Reads Code 39 and Code 128 Barcode.

C. Accessory Mount: The following optional items may be mounted here:
 50443 Laser Barcode Scanner
 50461 Ethernet Adapter
 Proximity Interface (contact manufacturer for more info)

D. SmartLog X³™ Wrist Strap / Footwear Tester: Default wrist strap test range is 1 - 10 megohms. The default footwear test range is 1 - 35 megohms. The default test ranges may be changed to suit personal ground device testing. See Technical Bulletin TB-6564 for instructions.



Figure 3. SmartLog X³™ features and components (Items 50734, 50735)

E. Magstripe Reader: Reads Track 2 Magstripe.

F. Laser Barcode Scanner: Can decode Code 39 (3 of 9) and Code 128 barcode.

G. SmartLog X³™ Wrist Strap / Footwear Tester: Default wrist strap test range is 1 - 10 megohms. The default footwear test range is 1 - 35 megohms. The default test ranges may be changed to suit personal ground device testing. See Technical Bulletin TB-7535 for instructions.

Configuring the Clock, Mounting the Unit, and Cable Connections

A. Clock's Baud Rate, ID, Parity, Daylight Option and Port Expand (See Figure 4)

1. Plug the power supply into the unit and then to the appropriate AC source. Refer to Figure 3 to locate the power input jack. The SmartLog X³™ will cycle through a self diagnostic program. The time and date will appear on the screen when the diagnostics is complete. Do not continue until this step has been completed.

NOTE: If any of the below settings are not correct, procede to step 2 and press the Advance button until the correct value appears on the display.

Power Requirement: It is highly recommended that these units are installed on power lines separate from other devices. The clock should not be installed on the same power line with devices containing electric motors. These units have a built-in self-healing fuse and surge, spike, and noise protection. The clock should be powered on a dedicated electrical circuit. If you are located in an area where there are frequent electrical storms, power surges, blackouts, or other similar problems we strongly recommend that the unit be placed on a surge protector.

2. After the self diagnosis press the MENU button six times. (If you do not press the Menu button within 20 seconds the clock will exit out of the set-up menu and will need to be reset by disconnecting then reconnecting the power supply.) Refer to Figure 3 for button locations.

3. Baud Rate should be set at 9600 (factory default). Press Enter for the next screen.

4. Parity should be set for ODD (factory default). Press Enter for next screen.

5. The SmartLog X³™ ID is a 2 digit field with valid I.D. numbers 00 through 63. Each SmartLog X³™ should have a different I.D. number if they are connected to the same communication line. The SmartLog X³™ should be numbered sequentially starting with 00, so that automatic polling in the software will not be interrupted.

6. The Daylight Option enables daylight savings in the clock.

7. Port Expand should be set to YES (factory default).

8. Press Enter button once more to cycle to the next setting before hitting the Menu button to exit.

NOTE: The setting will not change if you do not cycle to the next setting (by hitting the Enter button).

B. Terminator Jumper, RS-485 Switch, RS-232 Switch and Relay Terminal

1. The RS-485 is set default on SLAVE position (right side) and does not need to be switched unless the unit is in a daisy-chain. For units in a daisy-chain, set the RS-485 of the first SmartLog X³™ to MASTER (left position).

2. The Relay Terminal connections can be made on the back of the SmartLog X³™ (See Figure 3). They can be used to control doors, gates, etc. The relay terminal is limited to a maximum of 5A 250 VAC / 30 VDC and 10A 125 VAC.

3. The RS-232 Interface is described by the Electronic Industries Association (EIA) as EIA-232 or RS-232. Special consideration should be used when installing the communications cable. Keep a 3 feet separation distance from any EMF source (power wires, fluorescent lights, etc.) The cable length shall not exceed 50 feet from PC to unit. The EMIT 50641 Ethernet Adapter should be used if distance requirements exceed 50 feet.

C. Connecting the SmartLog X³™

NOTE: Both the SmartLog X³™ and computer should be turned off during the following procedures.

Connecting One SmartLog X³™ (See Figure 5)

1. Connect the Serial Adapter to the desired PC computer.

2. Connect one end of the provided RS-232 Non-Inverted Data Cable to the Serial Adapter.

3. Connect the other end of the RS-232 Non-inverted Data Cable to port labeled "RS-232" on the SmartLog X³™.

NOTE: Ensure that the SmartLog X³™ ID is set to 00 and its Terminator Jumper is left open.



Figure 4. Back-side of SmartLog X³™ plate

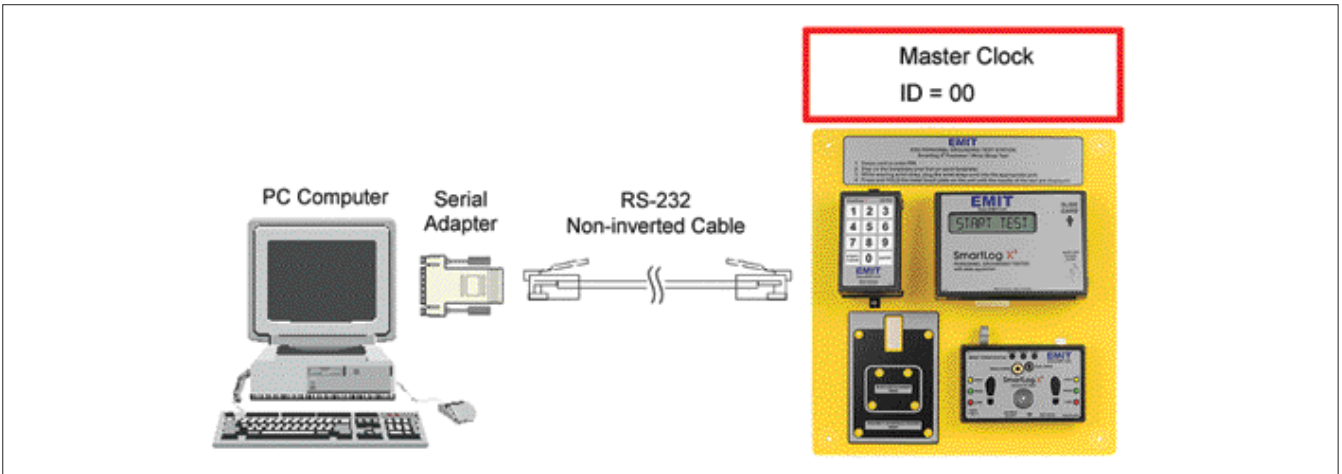

Figure 5. Connecting one SmartLog X³™

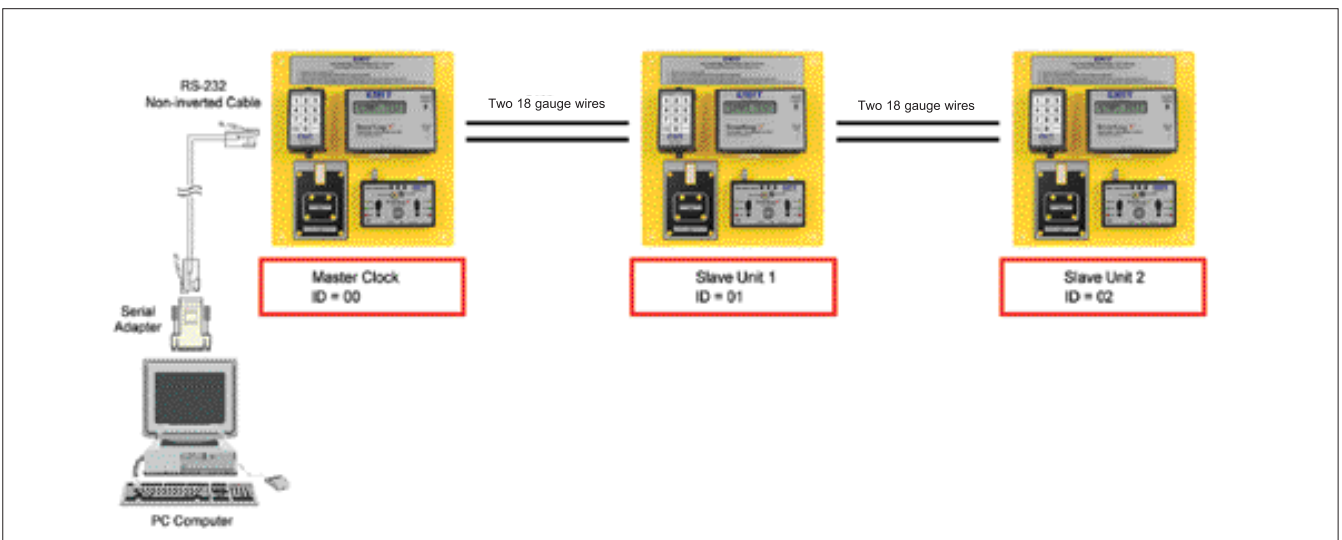

Figure 6. Connecting more than one SmartLog X³™

Connecting More Than One SmartLog X³™ (See Figure 6)

The following procedure provides an example on connecting 3 SmartLogs

1. Connect the Serial Adapter to the desired PC computer.
2. Connect one end of the provided RS-232 Non-inverted Data Cable to the Serial Adapter.
3. Connect the other end of the RS-232 Non-inverted Data Cable to clock port labeled "RS-232" on the SmartLog X³™.
4. Set first SmartLog X³™ ID to 00.
5. Connect one end of a pair of 18 gauge wires to the clock port labeled "RS-485" on the first SmartLog X³™.
6. Connect the other end of the pair of 18 gauge wires to the clock port labeled "RS-485" on the second SmartLog X³™.
7. Set second SmartLog X³™ ID to 01.
8. Connect one end of another pair of 18 gauge wires to the clock port labeled "RS-485" on the second SmartLog X³™.
9. Connect the other end of the same pair of 18 gauge wires to the clock port labeled "RS-485" on the third SmartLog X³™.
10. Set second SmartLog X³™ ID to 02.

D. Mounting the SmartLog X³™

Use the provided anchors and screws to mount the entire SmartLog X³™ plate. Be sure to place the SmartLog X³™ at a height where all operators can clearly see the display and perform the necessary tests.

When the hardware installation has been completed, refer to TB-6565 for TEAM Basic Software installation. TB-6565 will take you through the necessary steps to begin using your new SmartLog X³™.

Troubleshooting

Problem: The host computer is not recognizing the SmartLog X³™.

- a. Verify that the cable from the computer to the SmartLog X³™ is properly connected. The cable should be flat non-inverted (See Figure 4).
- b. Verify that the communication setup on the clock is 9600 baud rate, parity ODD. Refer to the instructions on back of SmartLog X³™ plate to enter configuration mode.
- c. If there are more than 2 units, verify that their IDs are unique by entering the SmartLog X³™ configuration mode.
- d. Contact your local IT department to verify that the computer's comport is working properly.
- e. Make sure that the SmartLog X³™ LED's are blinking during data transmission. If they are not blinking or remain on all the time, please contact EMIT technical support at 909-664-9980 for further support.

Contact

USA

EMIT

3651 Walnut Ave

Chino, CA 91710

TEL: 909-664-9980

FAX: 909-627-7449

EUROPE

Charleswater

Unit 17, Millbrook Business Park, Sybron Way

Crowborough, East Sussex, TN6 3JZ, U.K.

TEL: +44 (0) 189 266 5313

FAX: +44 (0) 189 266 8838

Limited Warranty

EMIT expressly warrants that for a period of five (5) years from the date of purchase an EMIT Smartlog X3 will be free of defects in material (parts) and workmanship (labor). Within the warranty period, a credit for purchase of a replacement EMIT Smartlog X3, or, at EMIT's option, the Smartlog X3 will be repaired or replaced free of charge. If product credit is issued, the amount will be calculated by multiplying the unused portion of the expected five year life times the original unit purchase price. Call our Customer Service Department at 909-664-9980 (Chino, CA) for a Return Material Authorization (RMA) and proper shipping instructions and address. Please include a copy of your original packing slip, invoice, or other proof of date of purchase. Any unit under warranty should be shipped prepaid to the EMIT factory. Warranty replacements will take approximately two weeks.

If your unit is out of warranty, call our Customer Service Department at 909-664-9980 (Chino, CA) for a Return Material Authorization (RMA) and proper shipping instructions and address. EMIT will quote repair charges necessary to bring your unit up to factory standards.

Warranty Exclusions

THE FOREGOING EXPRESS WARRANTY IS MADE IN LIEU OF ALL OTHER PRODUCT WARRANTIES, EXPRESSED AND IMPLIED, INCLUDING MERCHANTABILITY AND FITNESS FOR A PARTICULAR PURPOSE WHICH ARE SPECIFICALLY DISCLAIMED. The express warranty will not apply to defects or damage due to accidents, neglect, misuse, alterations, operator error, or failure to properly maintain, clean or repair products.

Limit of Liability

In no event will EMIT or any seller be responsible or liable for any injury, loss or damage, direct or consequential, arising out of the use of or the inability to use the product. Before using, users shall determine the suitability of the product for their intended use, and users assume all risk and liability whatsoever in connection therewith.