



3443-94

Locator Plate Instructions

Instructions for the assembly of 3M .100" x .100" and .100" x .200" socket connectors

General information

3M manual and pneumatic assembly presses and accessory assembly equipment are recommended for the termination of 3M socket connectors. 3M assembly equipment is offered to reduce set-up time, to provide easy and fast assembly, and to reduce assembly error.

.100" x .200" Backplane System Chart

Contact Quantity	3M Socket Part No.	Locator* Plate No. 3443	Locator Plate No. 3443	Assembly Platen 3442	Shut Height Adjustment for 3M Assembly Press		
					3316 & 3640	3335	3830
20	3575	-60 or -73	-94	-1A	12	12 ½	Self-adjusting
26	3501	-60 or -73	-94	-1A	12	12 ½	Self-adjusting
34	3310	-60 or -73	-94	-1A	12	12 ½	Self-adjusting
40	3318	-60 or -73	-94	-1A	12	12 ½	Self-adjusting
50	3307	-60 or -73	-94	-9A	12	12 ½	Self-adjusting

.100" x .100" Grid System Chart

Contact Quantity	3M Socket Part No.	Locator* Plate No. 3443	Locator Plate No. 3443	Assembly Platen 3442	Shut Height Adjustment for 3M Assembly Press		
					3316 & 3640	3335	3830
10	3473	-54 or -73	-94	-1A	12	12 ½	Self-adjusting
14	3385	-54 or -73	-94	-1A	12	12 ½	Self-adjusting
16	3452	-54 or -73	-94	-1A	12	12 ½	Self-adjusting
20	3421	-54 or -73	-94	-1A	12	12 ½	Self-adjusting
24	3626	-54 or -73	-94	-1A	12	12 ½	Self-adjusting
26	3399	-54 or -73	-94	-1A	12	12 ½	Self-adjusting
30	3419	-54 or -73	-94	-1A	12	12 ½	Self-adjusting
34	3414	-54 or -73	-94	-1A	12	12 ½	Self-adjusting
36	9436	-54 or -73	-94	-1A	12	12 ½	Self-adjusting
40	3417	-54 or -73	-94	-9A	12	12 ½	Self-adjusting
44	9444	-54 or -73	-94	-9A	12	12 ½	Self-adjusting
50	3425	-54 or -73	-94	-9A	12	12 ½	Self-adjusting
60	3334	-54 or -73	-94	-9A	12	12 ½	Self-adjusting
64	7964	-54 or -73	-94	-9A	12	12 ½	Self-adjusting

*The 3443-94 Locator Plate was designed to assemble all socket connectors, and replaces plates 3443-54, 3443-60, and 3443-73.

Set-up procedures for sockets, cables and guides

Adjustments to plate

Various adjustments are required to the locator plate, depending on which socket connector or cable is being assembled. Locator Plate 3443-94 is the recommended assembly aid. (See Figure 1)

The 3443-94 Locator Plate can be used to assemble:

- .1" x .1" and .1" x .2" socket connectors with and without center bump feature
- Socket connectors with standard flat cable and with ground plane cable

End Guide set-up

To adjust the position of the **end guide** for the *connector length* position, lift the end guide up and move it left or right. The viewing port on each end guide must align with the appropriate connector conductor size. The connector conductor size is specified by the numbers on the respective labels.

To adjust the **end guide** position for the .1" x .1" or .1" x .2" connector, lift and rotate the end guide 180° so that the

viewing port points to the respective .1" x .1" or .1" x .2" label guide.

Standard flat cable

To assemble **standard flat cable**, the cable width is guided between:

- The narrow end guide area
- The side of the end guide with the viewing port feature

Ground plane cable

To assemble ground plane cable, the cable width is guided between:

- The wide end guide area
- The side of the end guide that does not have the viewing port feature

Center bump feature

The center bump connector does not require any special set-up procedure.

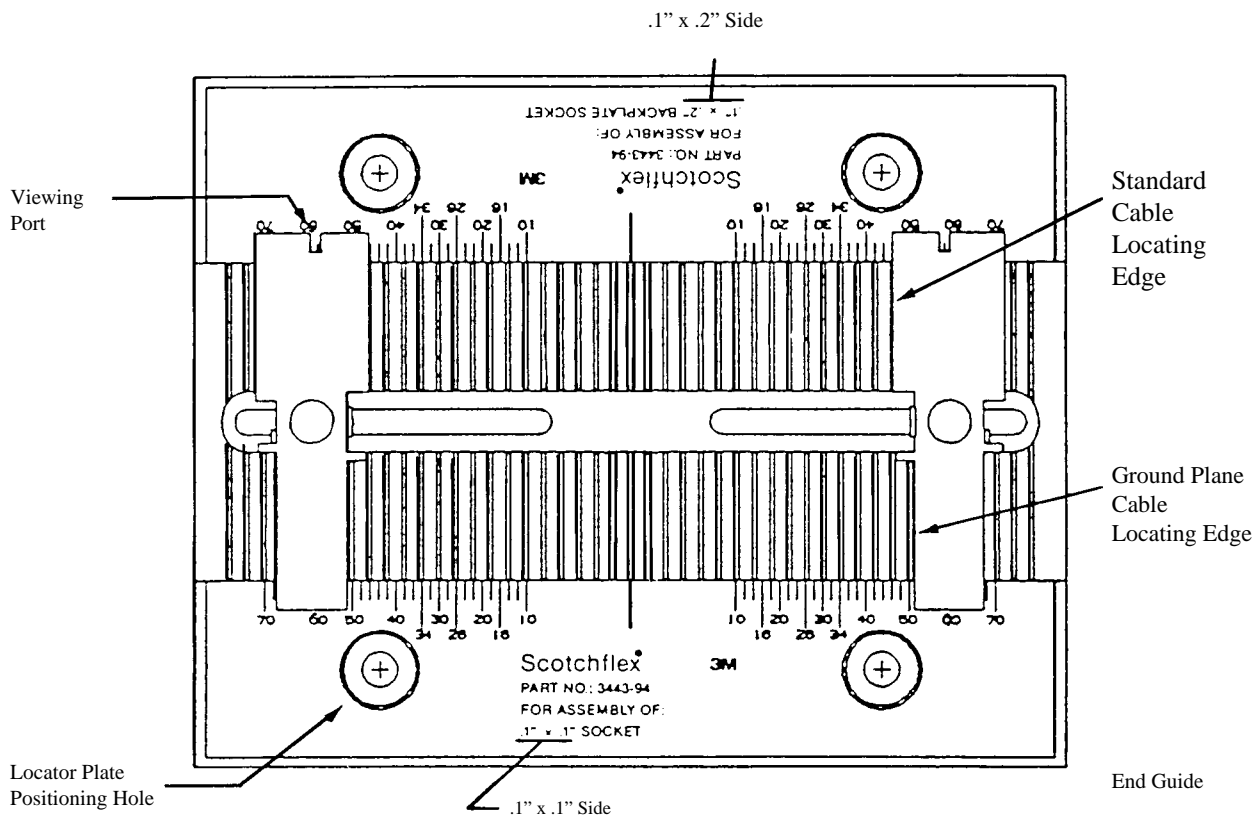

Figure 1.

Shut height adjustment procedures

The shut height setting is referenced in the **.100" x .200" Backplane System Chart and .100" x .100" Grid System Chart** on page 1. Shut height settings are guidelines for proper termination depth.

The shut height should be adjusted from the base before the locator plate is put into place. The 3316 and 3640 are adjusted with a knob at the top of the press. Press 3335 is adjusted with the collar on the press shaft, and Press 3830 is self-adjusting.

1. Place the shut height gauge, #3436-1A, across the base of the assembly press. Lower the handle of the press until the handle casting makes contact with the press casting. (See Figure 2)

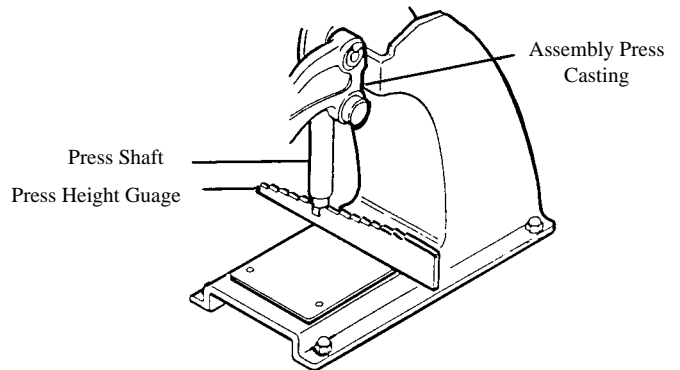

Figure 2.

2. Determine the type of assembly press you are using:

- With the **3335 Press**, lock the shut height adjustment collar toward the base of the press shaft. (See Figure 3a)
- With the **3316 and 3640 Presses**, turn the shut height adjustment knob until the bottom of the press shaft contacts the desired position on the shut height gauge. (See Figure 3b).

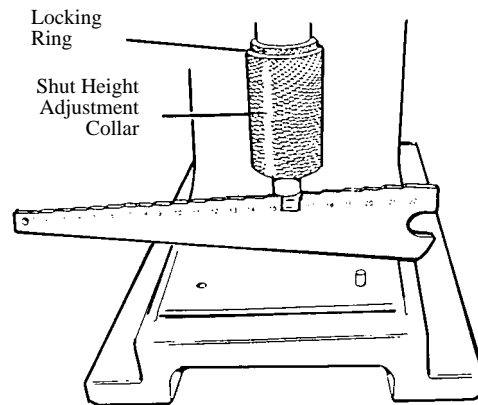

Figure 3a.

3335 Press Assembly

3. Install the locator plate and appropriate platen on the press. The platen should be positioned so that it is parallel with the connector body and cover.

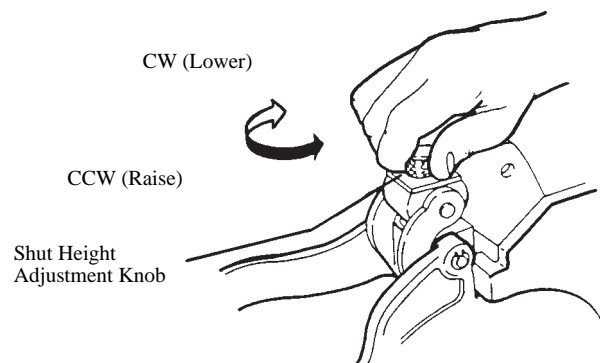

Figure 3b.

3316 & 3640 Press Assemblies

Connector/cable assembly procedures

1. Grasp a socket cover strip between thumb and forefinger of both hands, with the liner facing you. Rotate the outermost cover down against the adjacent cover on the strip, breaking it from the liner. Pull laterally away from the strip, leaving a clean adhesive edge on the removed cover. (See Figure 4)
2. Firmly press ribbed side of cable into alignment grooves on cover. The adhesive will help it stay in place. (See Figure 5)
3. Visually inspect to insure that:
 - Cable is properly aligned to cover grooves.
 - Cable end is flush with cover for end terminations, or perpendicular to cover for midspan terminations.
4. Place the cable/cover sub-assembly between the guides on the locator plate, cover side down. (See Figure 6)
5. Orient and position connector body — contacts down over the cable/cover sub-assembly, engaging cover retainer devices with body slots. (See Figure 6)
6. Lower the assembly press handle fully to complete the connection. (See Figure 7)
7. Raise press handle and remove completed assembly. Visually inspect to insure that:
 - Cover is fully seated and parallel with the body.
 - Cable is properly aligned with the cover grooves.
 - Cover retaining devices are completely engaged with the body.

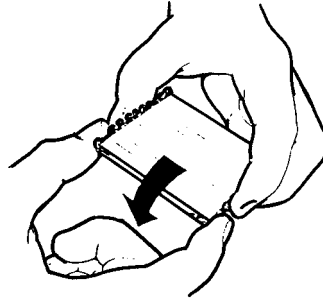

Figure 4.

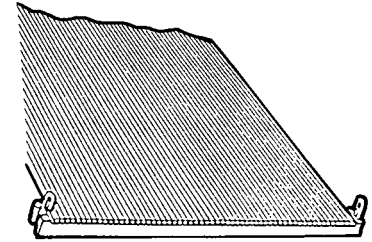

Figure 5.

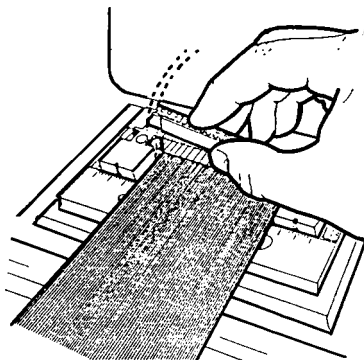

Figure 6.

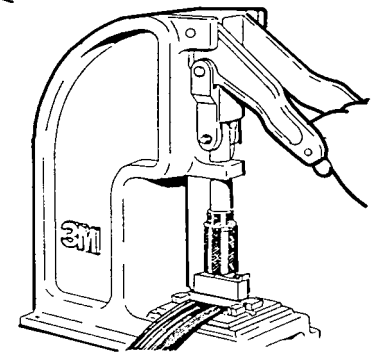

Figure 7.

Call 800-225-5373

for sales, ordering and technical product information

Important Notice

All statements, technical information and recommendations related to the Seller's products are based on information believed to be reliable, but the accuracy or completeness thereof is not guaranteed. Before utilizing the product, the user should determine the suitability of the product for its intended use. The user assumes all risks and liability whatsoever in connection with such use.

Any statements or recommendations of the Seller which are not contained in the Seller's current publications shall have no force or effect unless contained in an agreement signed by an authorized

officer of the Seller. The statements contained herein are made in lieu of all warranties, express or implied, including but not limited to the implied warranties of merchantability and fitness for a particular purpose which warranties are hereby expressly disclaimed.

Seller shall not be liable to the user or any other person under any legal theory, including but not limited to negligence or strict liability, for any injury or for any direct or consequential damages sustained or incurred by reason of the use of any of the seller's products that were defective.



Electronic Products Division
6801 River Place Blvd.
Austin, Texas 78726-9000



Printed on recycled paper.

Printed in the USA

© 3M 1993 34 7027 4814 5