

Type: **P1-25/I2/SVB**

Article No.: **207293**



### Ordering information

Design			Surface mounting
Description			Without auxiliary contacts
Main conducting paths No. of poles		M	3
Auxiliary contacts		N/O	0
Auxiliary contacts		B	0
Max. three-phase motor rating (per set of 3 contacts) 50–60 Hz AC–3 400/415 V 50–60 Hz	<i>P</i>	kW	13
Rated uninterrupted current	<i>I<sub>u</sub></i>	A	25
Note for table header			According to IEC/EN 60204–1, VDE 0113 Part 1; with red rotary handle and yellow locking collar, lockable in 0 position

### Contact sequence

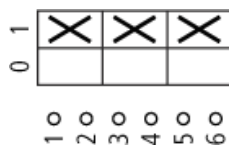

### General

Standards			IEC/EN 60947, VDE 0660, IEC/EN 60204, CSA, UL Switch-disconnectors to IEC/EN 60947–3
Lifespan, mechanical	Operations	$\times 10^6$	0,3

Maximum operating frequency	Operations/h		50
Climatic proofing			Damp heat, constant, to IEC 60068–2–78; Damp heat, cyclical, to IEC 60068–2–30
Ambient temperature			
Open		°C	–25/50
Enclosed		°C	–25/40
Mounting position			As required
Documentation			Main catalogue HPL
Mechanical shock resistance (shock duration 20 ms)		g	> 15

### Contacts

Rated operational voltage	$U_e$	V AC	690
Rated impulse withstand voltage	$U_{imp}$	V AC	6000
Overtoltage category/pollution degree			III/3
Rated uninterrupted current			
open	$I_u$	A	25
Enclosed	$I_u$	A	25
Load-carrying capacity in intermittent operation, Class 12			
AB 25 % DF		$\times I_e$	2
AB 40 % DF		$\times I_e$	1,6
AB 60 % DF		$\times I_e$	1,3
Short-circuit rating			
Fuse		A gG/gL	25
Rated short-time withstand current (1 s current)	$I_{cw}$	$A_{rms}$	640
Switching angles		°	90
Current heat loss per contact at $I_e$		W	1,1

### Terminal capacities

Solid or stranded		mm <sup>2</sup>	1 × (1.5 – 6) 2 × (1.5 – 6)
Flexible with ferrule to DIN 46228		mm <sup>2</sup>	1 × (1 – 4) 2 × (1 – 4)
Terminal screw			M4
Tightening torque		Nm	1.6

### Switching capacity

AC			
Rated making capacity $\cos \phi = 0.35$		A	240

Rated breaking capacity, motor load switch $\cos \phi = 0.35$			
230 V		A	190
400 V		A	150
500 V		A	170
690 V		A	150
Rated operational current 440 V load-break switch AC-21A	$I_e$	A	25
AC-3 motor load switch motor rating			
230 V	$P$	kW	5,5
400 V	$P$	kW	7,5
500 V	$P$	kW	7,5
690 V	$P$	kW	7,5
AC-23A Motor load switches (main switches maintenance switches)			
230 V	$P$	kW	7
400 V	$P$	kW	13
500 V	$P$	kW	11
690 V	$P$	kW	11
DC			
DC-1, Load-break switches L/R = 1 ms			
Rated operational current	$I_e$	A	25
Voltage per contact pair in series		V	60
DC-23A, Motor load switches L/R = 15 ms			
24 V			
Rated operational current	$I_e$	A	25
Contacts		Quantity	1
48 V			
Rated operational current	$I_e$	A	25
Contacts		Quantity	2
60 V			
Rated operational current	$I_e$	A	25
Contacts		Quantity	3
120 V			
Rated operational current	$I_e$	A	12
Contacts		Quantity	3

**Notes**

			<p>Main switch characteristics to IEC/EN 60204; positive opening of contacts, operator element positively located on shaft</p> <p>The rated uninterrupted current <math>I_u</math> is stated at max. connected cross-section. For terminal capacity solid, stranded and flexible: Max. 2 cross-section sizes difference admissible when using 2 conductors.</p>
--	--	--	---

**Dimensions**

			3 Padlocks
Explanation			<p>For utilisation category AC-4 (extreme load: 100 % inching, reversing or plugging)</p> <p>The blocked rotor current of the motor should not exceed the rated current of the switch for AC-21A to ensure a reasonable device lifespan.</p>

**Dimensions**

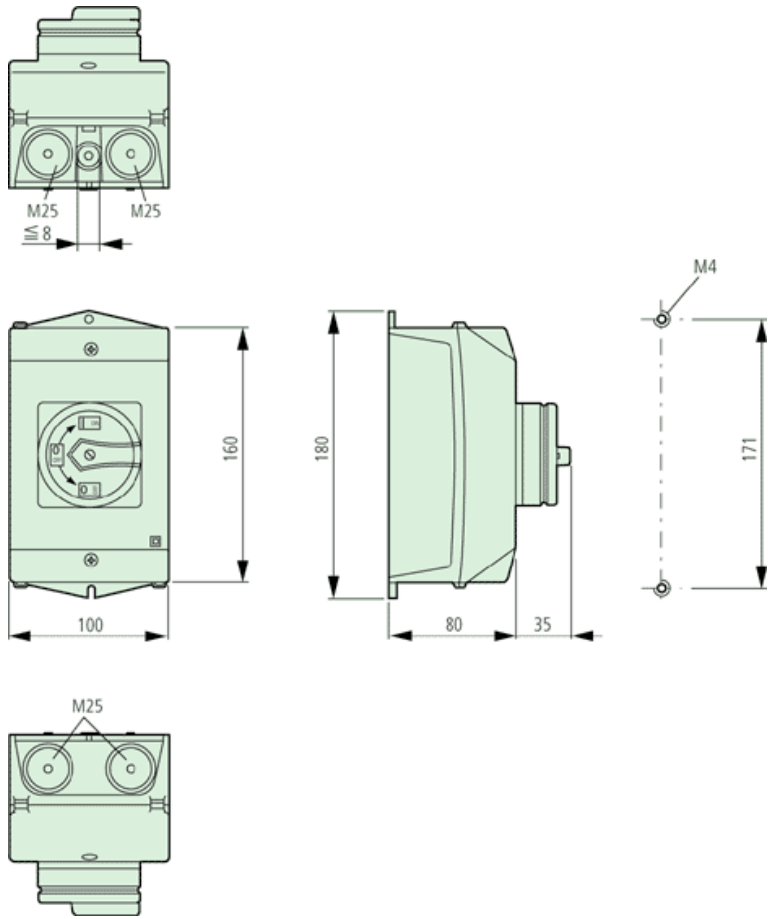

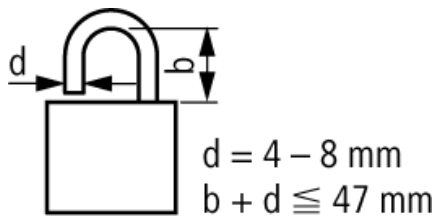

---

### Dimensions

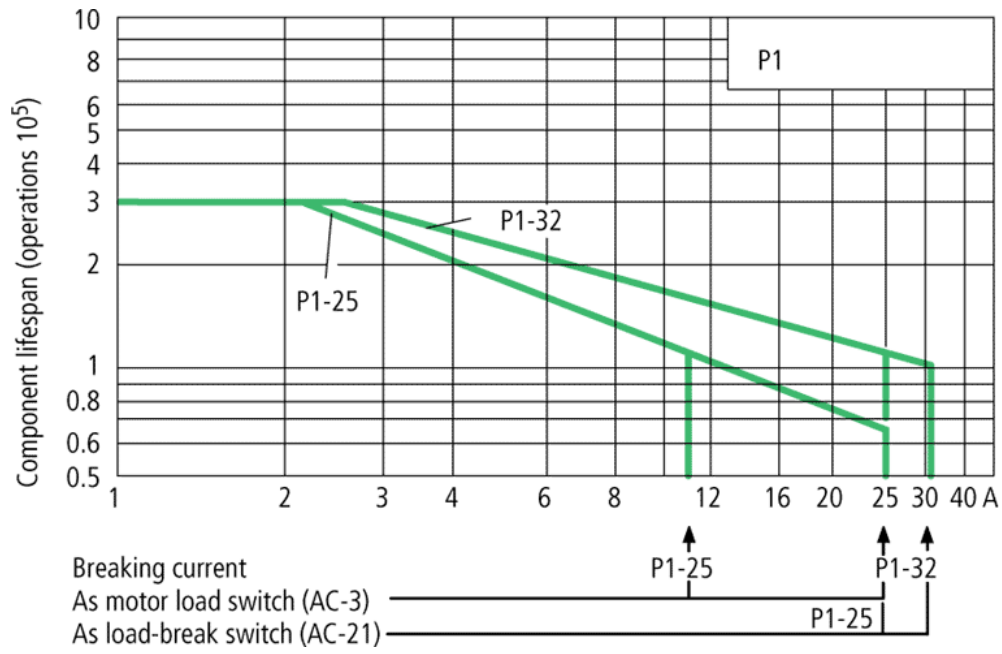

---

### Characteristic curve



Moeller GmbH, Hein-Moeller-Str. 7-11, D-53115 Bonn  
 E-Mail: [catalog@moeller.net](mailto:catalog@moeller.net), Internet: [www.moeller.net](http://www.moeller.net), <http://catalog.moeller.net>  
 Copyright 2006 by Moeller GmbH. Subject to modifications. HPL-C2006GB-INT V2.3