

LOC	DIST	REV	DESCRIPTION	DATE	OWN	APPD
E	B	P	LTR			
A			RELEASE FOR PRODUCTION	5-9-01	RG	FWK

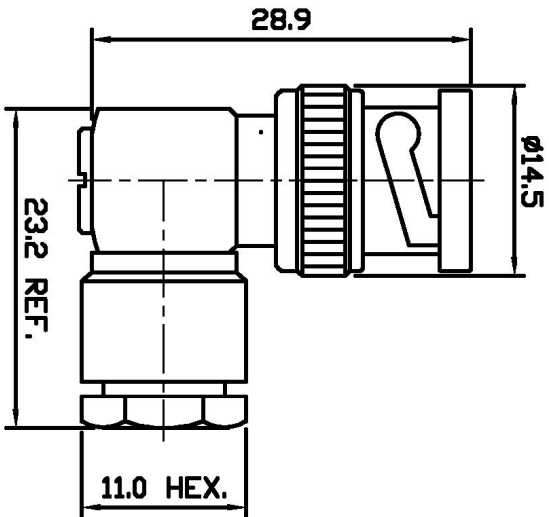

△ SUPPLIED SEMI-ASSEMBLED (PACK CONTAINS LOOSE PIECES)
 VIEW SHOWS ASSEMBLED CONNECTOR (CABLE OMITTED)
 FOR CABLE TO CONNECTOR ASSEMBLY GUIDANCE
 REFER TO TYCO INSTRUCTION SHEET IS 411 - 3266

ALL DIMENSIONS ARE NOMINAL. FOR REFERENCE ONLY.

DIE SET PART NUMBER	N/A
HANDTOOL PART NUMBER	N/A
FOR USE ON CABLES	RG59B/U, 62A/U, RG140/U
CONNECTOR PLATING DETAIL	SILVER
CONTACT PLATING DETAIL	SILVER
DIELECTRIC MATERIAL	PTFE
GASKET MATERIAL	WHITE SILICONE RUBBER

THIS DRAWING IS A CONTROLLED DOCUMENT.

DIMENSIONS:	MM
TOLERANCES UNLESS OTHERWISE SPECIFIED:	± .1
0 PLG	± .1
1 PLG	± .1
2 PLG	± .1
3 PLG	± .1
4 PLG	± .1
ANGLES	± .1
FINISH	-

DMN	R GOODALL	5-9-01	
CHK	F W-KING	5-9-01	
APPD	F W-KING	5-9-01	
PRODUCT SPEC	108-3435		
APPLICATION SPEC			
WEIGHT			
CUSTOMER DRAWING			

BAG	SINGLE ITEM	1-1478129-0
PACK TYPE	DESCRIPTION	PART NUMBER

tyco
 Tyco Electronics Corporation
 Stamford, Middlesex, HA7 4RS

BNC ELB PLUG SOLDER RG59 75 OHM

SIZE	A3	CAGE CODE	00779	DRAWING NO	1478129	RESTRICTED TO
SCALE	NTS	SHEET	1	OF	1	REV
						A