

## Fractional-N Clock Multiplier

### Features

- ◆ Clock Multiplier / Jitter Reduction
  - Generates a Low Jitter 6 - 75 MHz Clock from a Jittery or Intermittent 50 Hz to 30 MHz Clock Source
- ◆ Highly Accurate PLL Multiplication Factor
  - Maximum Error Less Than 1 PPM in High-Resolution Mode
- ◆ I<sup>2</sup>C<sup>®</sup> / SPI<sup>™</sup> Control Port
- ◆ Configurable Auxiliary Output
- ◆ Flexible Sourcing of Reference Clock
  - External Oscillator or Clock Source
  - Supports Inexpensive Local Crystal
- ◆ Minimal Board Space Required
  - No External Analog Loop-filter Components

### General Description

The CS2100-CP is an extremely versatile system clocking device that utilizes a programmable phase lock loop. The CS2100-CP is based on a hybrid analog-digital PLL architecture comprised of a unique combination of a Delta-Sigma Fractional-N Frequency Synthesizer and a Digital PLL. This architecture allows for generation of a low-jitter clock relative to an external noisy synchronization clock at frequencies as low as 50 Hz. The CS2100-CP supports both I<sup>2</sup>C and SPI for full software control.

The CS2100-CP is available in a 10-pin MSOP package in Commercial (-10°C to +70°C) grade. Customer development kits are also available for device evaluation. Please see ["Ordering Information" on page 32](#) for complete details.

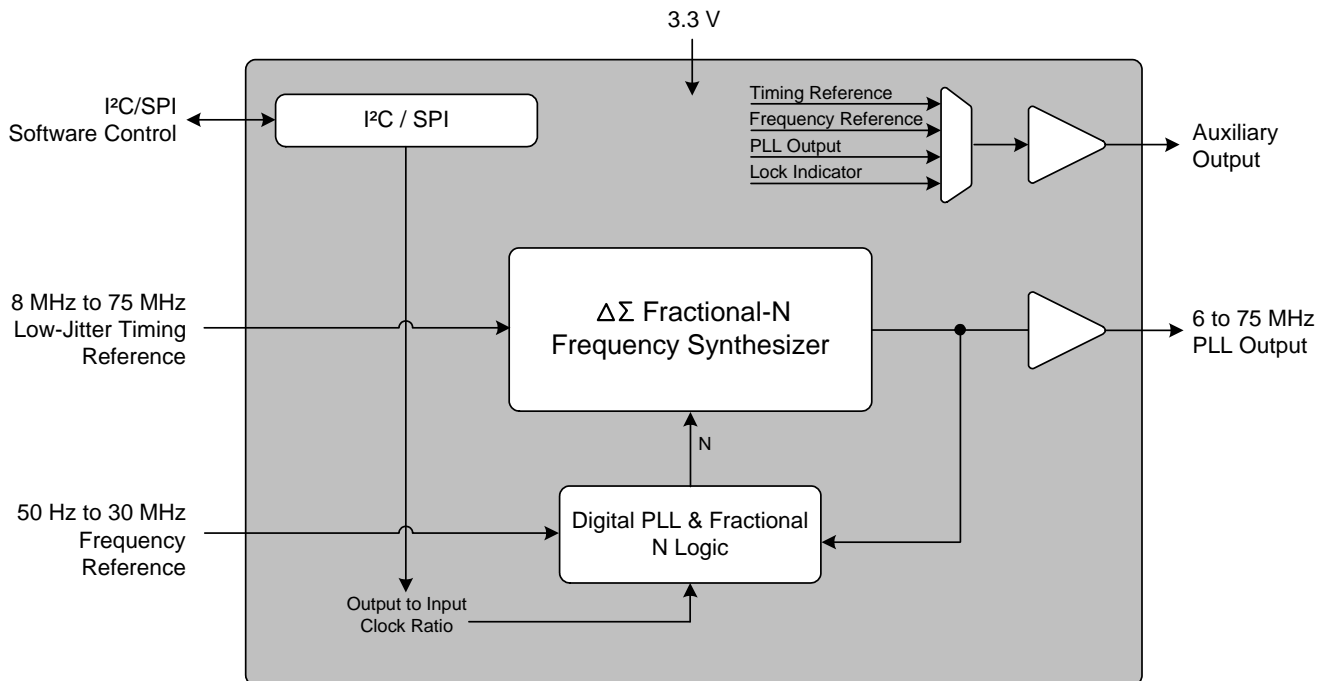

---

**TABLE OF CONTENTS**

<b>1. PIN DESCRIPTION .....</b>	<b>4</b>
<b>2. TYPICAL CONNECTION DIAGRAM .....</b>	<b>5</b>
<b>3. CHARACTERISTICS AND SPECIFICATIONS .....</b>	<b>6</b>
RECOMMENDED OPERATING CONDITIONS .....	6
ABSOLUTE MAXIMUM RATINGS .....	6
DC ELECTRICAL CHARACTERISTICS .....	6
AC ELECTRICAL CHARACTERISTICS .....	7
CONTROL PORT SWITCHING CHARACTERISTICS- I <sup>2</sup> C FORMAT .....	8
CONTROL PORT SWITCHING CHARACTERISTICS - SPI FORMAT .....	9
<b>4. ARCHITECTURE OVERVIEW .....</b>	<b>10</b>
4.1 Delta-Sigma Fractional-N Frequency Synthesizer .....	10
4.2 Hybrid Analog-Digital Phase Locked Loop .....	10
<b>5. APPLICATIONS .....</b>	<b>12</b>
5.1 Timing Reference Clock Input .....	12
5.1.1 Internal Timing Reference Clock Divider .....	12
5.1.2 Crystal Connections (XTI and XTO) .....	12
5.1.3 External Reference Clock (REF_CLK) .....	13
5.2 Frequency Reference Clock Input, CLK_IN .....	13
5.2.1 CLK_IN Frequency Detector .....	13
5.2.2 CLK_IN Skipping Mode .....	13
5.2.3 Adjusting the Minimum Loop Bandwidth for CLK_IN .....	15
5.3 Output to Input Frequency Ratio Configuration .....	16
5.3.1 User Defined Ratio (RUD) .....	16
5.3.2 Manual Ratio Modifier (R-Mod) .....	17
5.3.3 Automatic Ratio Modifier (Auto R-Mod) .....	17
5.3.4 Effective Ratio (REFF) .....	18
5.3.5 Ratio Configuration Summary .....	19
5.4 PLL Clock Output .....	20
5.5 Auxiliary Output .....	20
5.6 Clock Output Stability Considerations .....	21
5.6.1 Output Switching .....	21
5.6.2 PLL Unlock Conditions .....	21
<b>6. SPI / I<sup>2</sup>C CONTROL PORT .....</b>	<b>22</b>
6.1 SPI Control .....	22
6.2 I <sup>2</sup> C Control .....	22
6.3 Memory Address Pointer .....	24
6.3.1 Map Auto Increment .....	24
<b>7. REGISTER QUICK REFERENCE .....</b>	<b>24</b>
<b>8. REGISTER DESCRIPTIONS .....</b>	<b>25</b>
8.1 Device I.D. and Revision (Address 01h) .....	25
8.1.1 Device Identification (Device[4:0]) - Read Only .....	25
8.1.2 Device Revision (Revision[2:0]) - Read Only .....	25
8.2 Device Control (Address 02h) .....	25
8.2.1 Unlock Indicator (Unlock) - Read Only .....	25
8.2.2 PLL Input Sample Rate Indicator (FsDet[1:0]) - Read Only .....	25
8.2.3 Auto R-Modifier Enable (AutoRMod) .....	26
8.2.4 Auxiliary Output Disable (AuxOutDis) .....	26
8.2.5 PLL Clock Output Disable (ClkOutDis) .....	26
8.3 Device Configuration 1 (Address 03h) .....	26
8.3.1 R-Mod Selection (RModSel[2:0]) .....	26
8.3.2 Auxiliary Output Source Selection (AuxOutSrc[1:0]) .....	27
8.3.3 Enable Device Configuration Registers 1 (EnDevCfg1) .....	27

8.4 Global Configuration (Address 05h) .....	27
8.4.1 Device Configuration Freeze (Freeze) .....	27
8.4.2 Enable Device Configuration Registers 2 (EnDevCfg2) .....	27
8.5 Ratio (Address 06h - 09h) .....	28
8.6 Function Configuration 1 (Address 16h) .....	28
8.6.1 Clock Skip Enable (ClkSkipEn) .....	28
8.6.2 AUX PLL Lock Output Configuration (AuxLockCfg) .....	28
8.6.3 Reference Clock Input Divider (RefClkDiv[1:0]) .....	28
8.7 Function Configuration 2 (Address 17h) .....	29
8.7.1 Enable PLL Clock Output on Unlock (ClkOutUnl) .....	29
8.7.2 Low-Frequency Ratio Configuration (LFRatioCfg) .....	29
8.8 Function Configuration 3 (Address 1Eh) .....	29
8.8.1 Clock Input Bandwidth (ClkIn_BW[2:0]) .....	29
<b>9. CALCULATING THE USER DEFINED RATIO .....</b>	<b>30</b>
9.1 High Resolution 12.20 Format .....	30
9.2 High Multiplication 20.12 Format .....	30
<b>10. PACKAGE DIMENSIONS .....</b>	<b>31</b>
THERMAL CHARACTERISTICS .....	31
<b>11. ORDERING INFORMATION .....</b>	<b>32</b>
<b>12. REFERENCES .....</b>	<b>32</b>
<b>13. REVISION HISTORY .....</b>	<b>32</b>

## LIST OF FIGURES

Figure 1. Typical Connection Diagram .....	5
Figure 2. Control Port Timing - I <sup>2</sup> C Format .....	8
Figure 3. Control Port Timing - SPI Format (Write Only) .....	9
Figure 4. Delta-Sigma Fractional-N Frequency Synthesizer .....	10
Figure 5. Hybrid Analog-Digital PLL .....	11
Figure 6. Internal Timing Reference Clock Divider .....	12
Figure 7. External Component Requirements for Crystal Circuit .....	12
Figure 8. CLK_IN removed for > 2 <sup>23</sup> SysClk cycles .....	14
Figure 9. CLK_IN removed for < 2 <sup>23</sup> SysClk cycles but > t <sub>CS</sub> .....	14
Figure 10. CLK_IN removed for < t <sub>CS</sub> .....	14
Figure 11. Low bandwidth and new clock domain .....	15
Figure 12. High bandwidth with CLK_IN domain re-use .....	15
Figure 13. Ratio Feature Summary .....	19
Figure 14. PLL Clock Output Options .....	20
Figure 15. Auxiliary Output Selection .....	20
Figure 16. Control Port Timing in SPI Mode .....	22
Figure 17. Control Port Timing, I <sup>2</sup> C Write .....	23
Figure 18. Control Port Timing, I <sup>2</sup> C Aborted Write + Read .....	23

## LIST OF TABLES

Table 1. PLL Input Clock Range Indicator .....	13
Table 2. Ratio Modifier .....	17
Table 3. Automatic Ratio Modifier .....	17
Table 4. Example Audio Oversampling Clock Generation from CLK_IN .....	18
Table 5. Example 12.20 R-Values .....	30
Table 6. Example 20.12 R-Values .....	30

## 1. PIN DESCRIPTION

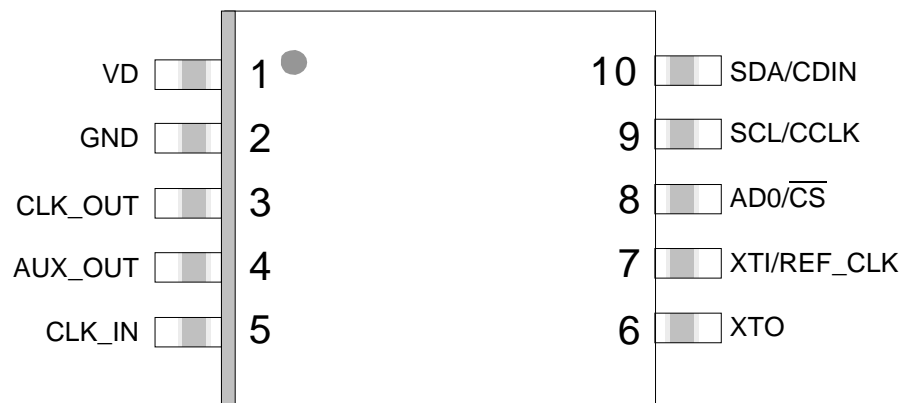

Pin Name	#	Pin Description
VD	1	<b>Digital Power (Input)</b> - Positive power supply for the digital and analog sections.
GND	2	<b>Ground (Input)</b> - Ground reference.
CLK_OUT	3	<b>PLL Clock Output (Output)</b> - PLL clock output.
AUX_OUT	4	<b>Auxiliary Output (Output)</b> - This pin outputs a buffered version of one of the input or output clocks, or a status signal, depending on register configuration.
CLK_IN	5	<b>Frequency Reference Clock Input (Input)</b> - Clock input for the Digital PLL frequency reference.
XTO XTI/REF_CLK	6 7	<b>Crystal Connections (XTI/XTO) / Timing Reference Clock Input (REF_CLK) (Input/Output)</b> - XTI/XTO are I/O pins for an external crystal which may be used to generate the low-jitter PLL input clock. REF_CLK is an input for an externally generated low-jitter reference clock.
AD0/CS	8	<b>Address Bit 0 (I<sup>2</sup>C) / Control Port Chip Select (SPI) (Input)</b> - AD0 is a chip address pin in I <sup>2</sup> C Mode. CS is the chip select signal in SPI Mode.
SCL/CCLK	9	<b>Control Port Clock (Input)</b> - SCL/CCLK is the serial clock for the serial control port in I <sup>2</sup> C and SPI mode.
SDA/CDIN	10	<b>Serial Control Data (Input/Output)</b> - SDA is the data I/O line in I <sup>2</sup> C Mode. CDIN is the input data line for the control port interface in SPI Mode.

## 2. TYPICAL CONNECTION DIAGRAM

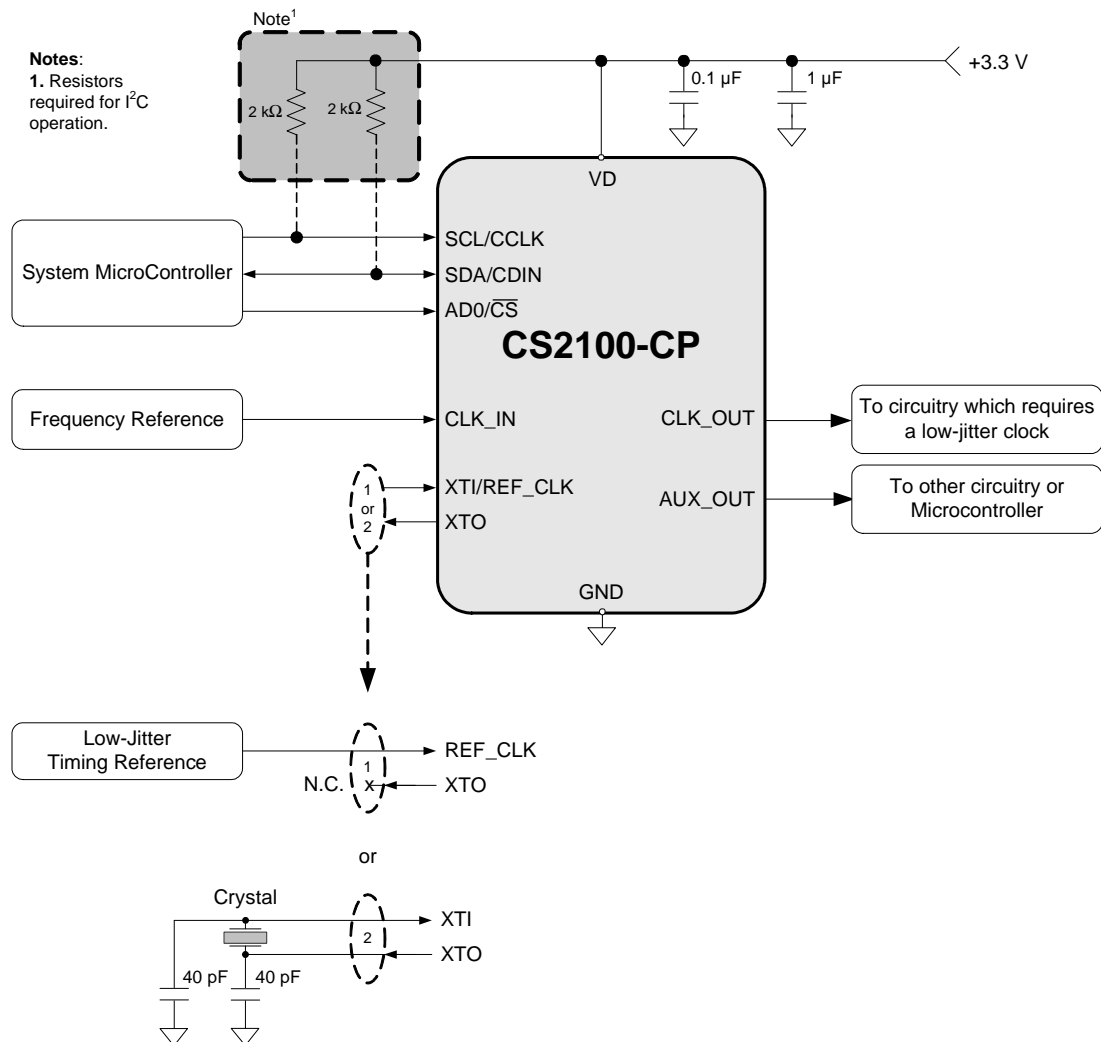

**Figure 1. Typical Connection Diagram**

### 3. CHARACTERISTICS AND SPECIFICATIONS

#### RECOMMENDED OPERATING CONDITIONS

GND = 0 V; all voltages with respect to ground. (Note 1)

Parameters	Symbol	Min	Typ	Max	Units
DC Power Supply	VD	3.1	3.3	3.5	V
Ambient Operating Temperature (Power Applied) Commercial Grade	T <sub>AC</sub>	-10	-	+70	°C

**Notes:** 1. Device functional operation is guaranteed within these limits. Functionality is not guaranteed or implied outside of these limits. Operation outside of these limits may adversely affect device reliability.

#### ABSOLUTE MAXIMUM RATINGS

GND = 0 V; all voltages with respect to ground.

Parameters	Symbol	Min	Max	Units
DC Power Supply	VD	-0.3	6.0	V
Input Current	I <sub>IN</sub>	-	±10	mA
Digital Input Voltage (Note 1)	V <sub>IN</sub>	-0.3	VD + 0.4	V
Ambient Operating Temperature (Power Applied)	T <sub>A</sub>	-55	125	°C
Storage Temperature	T <sub>stg</sub>	-65	150	°C

**WARNING:** Operation at or beyond these limits may result in permanent damage to the device.

**Notes:** 1. The maximum over/under voltage is limited by the input current except on the power supply pin.

#### DC ELECTRICAL CHARACTERISTICS

Test Conditions (unless otherwise specified): VD = 3.1 V to 3.5 V; T<sub>A</sub> = -10°C to +70°C (Commercial Grade).

Parameters	Symbol	Min	Typ	Max	Units
Power Supply Current - Unloaded (Note 2)	I <sub>D</sub>	-	12	18	mA
Power Dissipation - Unloaded (Note 2)	P <sub>D</sub>	-	40	60	mW
Input Leakage Current	I <sub>IN</sub>	-	-	±10	µA
Input Capacitance	I <sub>C</sub>	-	8	-	pF
High-Level Input Voltage	V <sub>IH</sub>	70%	-	-	VD
Low-Level Input Voltage	V <sub>IL</sub>	-	-	30%	VD
High-Level Output Voltage (I <sub>OH</sub> = -1.2 mA)	V <sub>OH</sub>	80%	-	-	VD
Low-Level Output Voltage (I <sub>OH</sub> = 1.2 mA)	V <sub>OL</sub>	-	-	20%	VD

**Notes:** 2. To calculate the additional current consumption due to loading (per output pin), multiply clock output frequency by load capacitance and power supply voltage.  
For example, f<sub>CLK\_OUT</sub> (49.152 MHz) \* C<sub>L</sub> (15 pF) \* VD (3.3 V) = 2.4 mA of additional current due to these loading conditions on CLK\_OUT.

## AC ELECTRICAL CHARACTERISTICS

Test Conditions (unless otherwise specified):  $V_D = 3.1\text{ V to }3.5\text{ V}$ ;  $T_A = -10^\circ\text{C to }+70^\circ\text{C}$  (Commercial Grade);  $C_L = 15\text{ pF}$ .

Parameters	Symbol	Conditions	Min	Typ	Max	Units
Crystal Frequency	$f_{XTAL}$	Fundamental Mode	8	-	50	MHz
Reference Clock Input Frequency	$f_{REF\_CLK}$		8	-	75	MHz
Reference Clock Input Duty Cycle	$D_{REF\_CLK}$		45	-	55	%
Internal System Clock Frequency	$f_{SYS\_CLK}$		8		18.75	MHz
Clock Input Frequency (Auto R-Mod Disabled)	$f_{CLK\_IN}$		50 Hz	-	30	MHz
Clock Input Frequency (Auto R-mod Enabled)	$f_{CLK\_IN}$	Auto R Modifier = 1 Auto R Modifier = 0.5 Auto R Modifier = 0.25	4 72 168	- - -	59 138 256	kHz kHz kHz
Clock Input Pulse Width (Note 3)	$PW_{CLK\_IN}$	$f_{CLK\_IN} < f_{SYS\_CLK}/96$ $f_{CLK\_IN} > f_{SYS\_CLK}/96$	2 10	- -	- -	UI ns
Clock Skipping Timeout	$t_{CS}$	(Notes 4, 5)	20	-	-	ms
Clock Skipping Input Frequency	$f_{CLK\_SKIP}$	(Note 5)	50 Hz	-	80	kHz
PLL Clock Output Frequency	$f_{CLK\_OUT}$		6	-	75	MHz
PLL Clock Output Duty Cycle	$t_{OD}$	Measured at $V_D/2$	48	50	52	%
Clock Output Rise Time	$t_{OR}$	20% to 80% of $V_D$	-	1.7	3.0	ns
Clock Output Fall Time	$t_{OF}$	80% to 20% of $V_D$	-	1.7	3.0	ns
Period Jitter	$t_{JIT}$	(Note 6)	-	70	150	ps rms
Base Band Jitter (100 Hz to 40 kHz)		(Notes 6, 7)	-	50	-	ps rms
Wide Band Jitter (100 Hz Corner)		(Notes 6, 8)	-	175	-	ps rms
PLL Lock Time - CLK_IN (Note 9)	$t_{LC}$	$f_{CLK\_IN} < 200\text{ kHz}$ $f_{CLK\_IN} > 200\text{ kHz}$	- -	100 1	200 3	UI ms
PLL Lock Time - REF_CLK	$t_{LR}$	$f_{REF\_CLK} = 8\text{ to }75\text{ MHz}$	-	1	2	ms
Output Frequency Synthesis Resolution (Note 10)	$f_{err}$	High Resolution High Multiplication	0 0	- -	$\pm 0.5$ $\pm 112$	ppm ppm

- Notes:**
- 1 UI (unit interval) corresponds to  $t_{SYS\_CLK}$  or  $1/f_{SYS\_CLK}$ .
  - $t_{CS}$  represents the time from the removal of  $CLK\_IN$  by which  $CLK\_IN$  must be re-applied to ensure that  $PLL\_OUT$  continues while the PLL re-acquires lock. This timeout is based on the internal VCO frequency, with the minimum timeout occurring at the maximum VCO frequency. Lower VCO frequencies will result in larger values of  $t_{CS}$ .
  - Only valid in clock skipping mode; See "[CLK\\_IN Skipping Mode](#)" on page 13 for more information.
  - $f_{CLK\_OUT} = 24.576\text{ MHz}$ ; Sample size = 10,000 points;  $AuxOutSrc[1:0] = 11$ .
  - In accordance with AES-12id-2006 section 3.4.2. Measurements are Time Interval Error taken with 3rd order 100 Hz to 40 kHz bandpass filter.
  - In accordance with AES-12id-2006 section 3.4.1. Measurements are Time Interval Error taken with 3rd order 100 Hz Highpass filter.
  - 1 UI (unit interval) corresponds to  $t_{CLK\_IN}$  or  $1/f_{CLK\_IN}$ .
  - The frequency accuracy of the PLL clock output is directly proportional to the frequency accuracy of the reference clock.

## CONTROL PORT SWITCHING CHARACTERISTICS- I<sup>2</sup>C FORMAT

Inputs: Logic 0 = GND; Logic 1 = VD; C<sub>L</sub> = 20 pF.

Parameter	Symbol	Min	Max	Unit
SCL Clock Frequency	f <sub>scl</sub>	-	100	kHz
Bus Free-Time Between Transmissions	t <sub>buf</sub>	4.7	-	μs
Start Condition Hold Time (prior to first clock pulse)	t <sub>hdst</sub>	4.0	-	μs
Clock Low Time	t <sub>low</sub>	4.7	-	μs
Clock High Time	t <sub>high</sub>	4.0	-	μs
Setup Time for Repeated Start Condition	t <sub>sust</sub>	4.7	-	μs
SDA Hold Time from SCL Falling (Note 11)	t <sub>hdd</sub>	0	-	μs
SDA Setup Time to SCL Rising	t <sub>sud</sub>	250	-	ns
Rise Time of SCL and SDA	t <sub>r</sub>	-	1	μs
Fall Time SCL and SDA	t <sub>f</sub>	-	300	ns
Setup Time for Stop Condition	t <sub>susp</sub>	4.7	-	μs
Acknowledge Delay from SCL Falling	t <sub>ack</sub>	300	1000	ns
Delay from Supply Voltage Stable to Control Port Ready	t <sub>dpor</sub>	100	-	μs

**Notes:** 11. Data must be held for sufficient time to bridge the transition time, t<sub>f</sub>, of SCL.

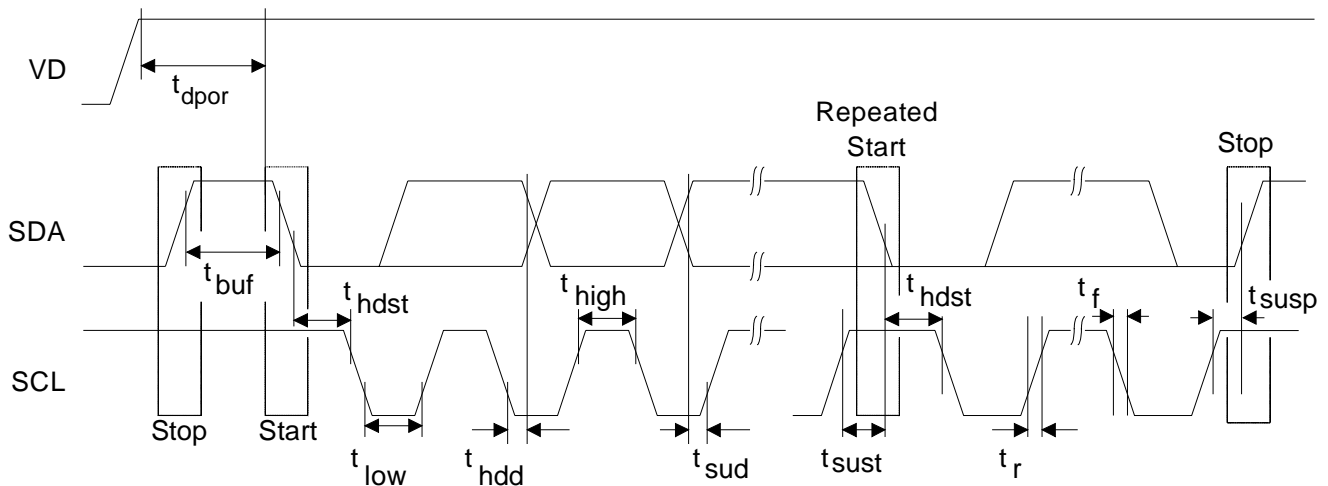

**Figure 2. Control Port Timing - I<sup>2</sup>C Format**



## CONTROL PORT SWITCHING CHARACTERISTICS - SPI FORMAT

Inputs: Logic 0 = GND; Logic 1 = VD;  $C_L = 20$  pF.

Parameter	Symbol	Min	Max	Unit
CCLK Clock Frequency	$f_{cclk}$	-	6	MHz
CCLK Edge to $\overline{CS}$ Falling (Note 12)	$t_{spi}$	500	-	ns
CS High Time Between Transmissions	$t_{csh}$	1.0	-	$\mu$ s
CS Falling to CCLK Edge	$t_{css}$	20	-	ns
CCLK Low Time	$t_{scl}$	66	-	ns
CCLK High Time	$t_{sch}$	66	-	ns
CDIN to CCLK Rising Setup Time	$t_{dsu}$	40	-	ns
CCLK Rising to DATA Hold Time (Note 13)	$t_{dh}$	15	-	ns
Rise Time of CCLK and CDIN (Note 14)	$t_{r2}$	-	100	ns
Fall Time of CCLK and CDIN (Note 14)	$t_{f2}$	-	100	ns
Delay from Supply Voltage Stable to Control Port Ready	$t_{dpor}$	100	-	$\mu$ s

- Notes:** 12.  $t_{spi}$  is only needed before first falling edge of  $\overline{CS}$  after power is applied.  $t_{spi} = 0$  at all other times.  
 13. Data must be held for sufficient time to bridge the transition time of CCLK.  
 14. For  $f_{cclk} < 1$  MHz.

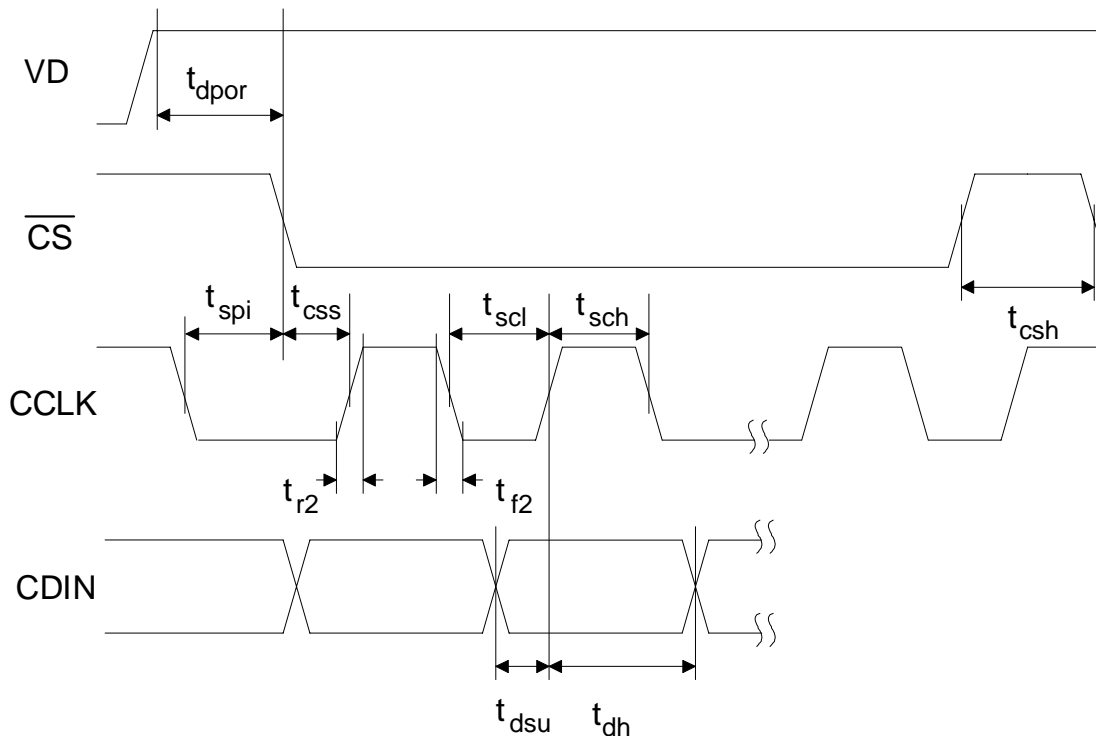

Figure 3. Control Port Timing - SPI Format (Write Only)

## 4. ARCHITECTURE OVERVIEW

### 4.1 Delta-Sigma Fractional-N Frequency Synthesizer

The core of the CS2100 is a Delta-Sigma Fractional-N Frequency Synthesizer which has very high-resolution for Input/Output clock ratios, low phase noise, very wide range of output frequencies and the ability to quickly tune to a new frequency. In very simplistic terms, the Fractional-N Frequency Synthesizer multiplies the Timing Reference Clock by the value of N to generate the PLL output clock. The desired output to input clock ratio is the value of N that is applied to the delta-sigma modulator (see [Figure 4](#)).

The analog PLL based frequency synthesizer uses a low-jitter timing reference clock as a time and phase reference for the internal voltage controlled oscillator (VCO). The phase comparator compares the fractional-N divided clock with the original timing reference and generates a control signal. The control signal is filtered by the internal loop filter to generate the VCO's control voltage which sets its output frequency. The delta-sigma modulator modulates the loop integer divide ratio to get the desired fractional ratio between the reference clock and the VCO output (thus the one's density of the modulator sets the fractional value). This allows the design to be optimized for very fast lock times for a wide range of output frequencies without the need for external filter components. As with any Fractional-N Frequency Synthesizer the timing reference clock should be stable and jitter-free.

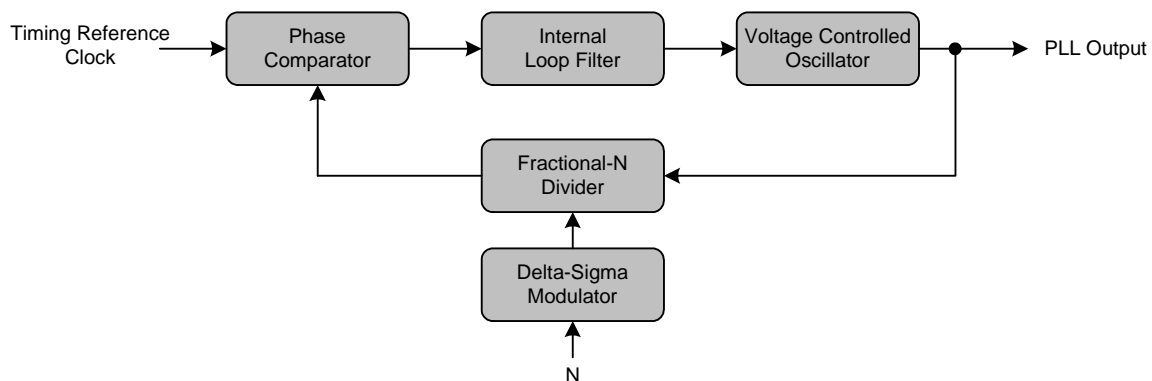

**Figure 4. Delta-Sigma Fractional-N Frequency Synthesizer**

### 4.2 Hybrid Analog-Digital Phase Locked Loop

The addition of the Digital PLL and Fractional-N Logic (shown in [Figure 5](#)) to the Fractional-N Frequency Synthesizer creates the Hybrid Analog-Digital Phase Locked Loop with many advantages over classical analog PLL techniques. These advantages include the ability to operate over extremely wide frequency ranges without the need to change external loop filter components while maintaining impressive jitter reduction performance. In the Hybrid architecture, the Digital PLL calculates the ratio of the PLL output clock to the frequency reference and compares that to the desired ratio. The digital logic generates a value of N which is then applied to the Fractional-N frequency synthesizer to generate the desired PLL output frequency. Notice that the frequency and phase of the timing reference signal do not affect the output of the PLL since the digital control loop will correct for the PLL output. A major advantage of the Digital PLL is the ease with which the loop filter bandwidth can be altered. The PLL bandwidth is automatically set to a wide-bandwidth mode to quickly achieve lock and then reduced for optimal jitter rejection.

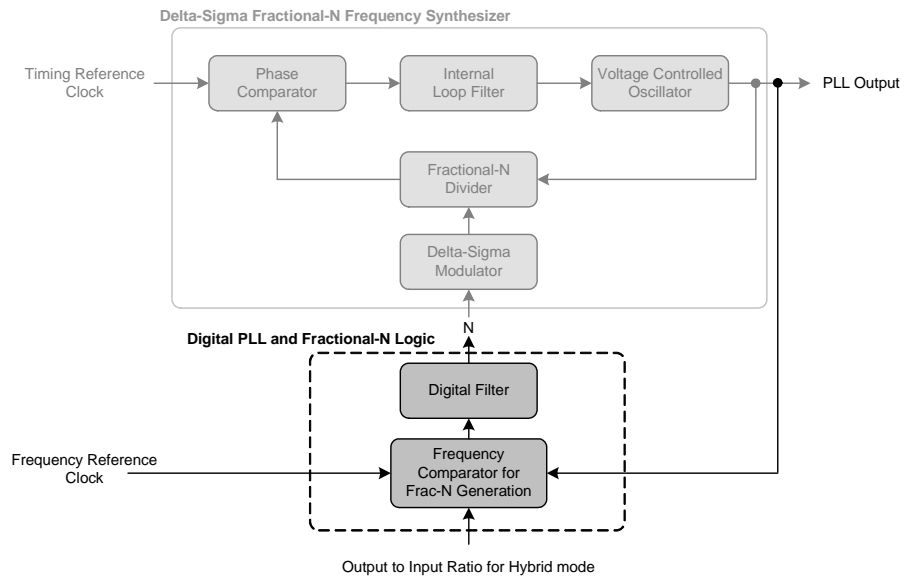

**Figure 5. Hybrid Analog-Digital PLL**

## 5. APPLICATIONS

### 5.1 Timing Reference Clock Input

The low jitter timing reference clock (RefClk) can be provided by either an external reference clock or an external crystal in conjunction with the internal oscillator. In order to maintain a stable and low-jitter PLL output the timing reference clock must also be stable and low-jitter; the quality of the timing reference clock directly affects the performance of the PLL and hence the quality of the PLL output.

#### 5.1.1 Internal Timing Reference Clock Divider

The Internal Timing Reference Clock (SysClk) has a smaller maximum frequency than what is allowed on the XTI/REF\_CLK pin. The CS2100 supports the wider external frequency range by offering an internal divider for RefClk. The *RefClkDiv[1:0]* bits should be set such that SysClk, the divided RefClk, then falls within the valid range as indicated in [Figure 6](#).

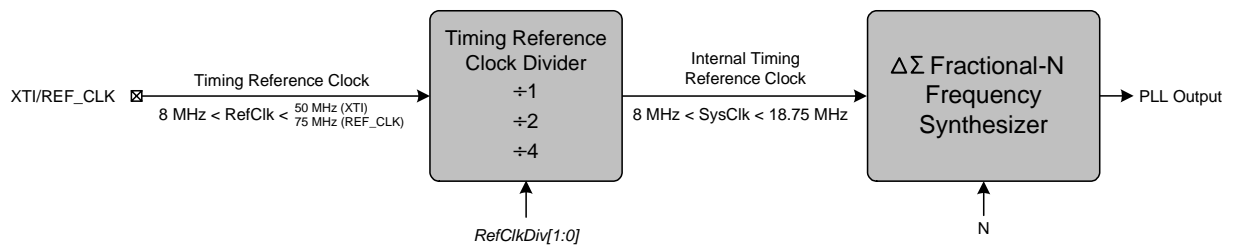

**Figure 6. Internal Timing Reference Clock Divider**

It should be noted that the maximum allowable input frequency of the XTI/REF\_CLK pin is dependent upon its configuration as either a crystal connection or external clock input. See the [“AC Electrical Characteristics” on page 7](#) for more details.

Referenced Control	Register Location
RefClkDiv[1:0] .....	“Reference Clock Input Divider (RefClkDiv[1:0])” on page 28

#### 5.1.2 Crystal Connections (XTI and XTO)

An external crystal may be used to generate RefClk. To accomplish this, a 20 pF fundamental mode parallel resonant crystal must be connected between the XTI and XTO pins as shown in [Figure 7](#). As shown, nothing other than the crystal and its load capacitors should be connected to XTI and XTO. Please refer to the [“AC Electrical Characteristics” on page 7](#) for the allowed crystal frequency range.

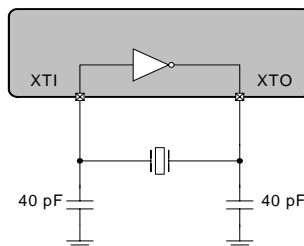

**Figure 7. External Component Requirements for Crystal Circuit**

### 5.1.3 External Reference Clock (REF\_CLK)

For operation with an externally generated REF\_CLK signal, XT1/REF\_CLK should be connected to the reference clock source and XTO should be left unconnected or pulled low through a 47 kΩ resistor to GND.

## 5.2 Frequency Reference Clock Input, CLK\_IN

The frequency reference clock input (CLK\_IN) is used by the Digital PLL and Fractional-N Logic block to dynamically generate a fractional-N value for the Frequency Synthesizer (see “Hybrid Analog-Digital PLL” on page 11). The Digital PLL first compares the CLK\_IN frequency to the PLL output. The Fractional-N logic block then translates the desired ratio based off of CLK\_IN to one based off of the internal timing reference clock (SysClk). This allows the low-jitter timing reference clock to be used as the clock which the Frequency Synthesizer multiplies while maintaining synchronicity with the frequency reference clock through the Digital PLL. The allowable frequency range for CLK\_IN is found in the “AC Electrical Characteristics” on page 7.

### 5.2.1 CLK\_IN Frequency Detector

The CLK\_IN frequency range detector determines and indicates the ratio between the frequency of the internal SysClk and the CLK\_IN input signal.

The result of the ratio measurement is available in the read-only *FsDet[1:0]* bits and is also used by the device to determine the Auto R-Mod value.

<b>FsDetect[1:0]</b>	<b>f<sub>SysClk</sub> / f<sub>CLK_IN</sub> Ratio</b>
00	> 224
01	96 - 224
10	< 96
11	Reserved

**Table 1. PLL Input Clock Range Indicator**

Because  $f_{\text{SysClk}}$  is known, *FsDet[1:0]* can then be interpreted as a range for  $f_{\text{CLK\_IN}}$ . This feature is particularly useful when used in conjunction with the Auto R-Mod feature (see section 5.3.3 on page 17).

<b>Referenced Control</b>	<b>Register Location</b>
FsDet[1:0].....	“PLL Input Sample Rate Indicator (FsDet[1:0]) - Read Only” section on page 25

### 5.2.2 CLK\_IN Skipping Mode

CLK\_IN skipping mode allows the PLL to maintain lock even when the CLK\_IN signal has missing pulses for up to 20 ms ( $t_{\text{CS}}$ ) at a time (see “AC Electrical Characteristics” on page 7 for specifications). CLK\_IN skipping mode can only be used when the CLK\_IN frequency is below 80 kHz. The *ClkSkipEn* bit enables this function.

Regardless of the setting of the *ClkSkipEn* bit the PLL output will continue for  $2^{23}$  SysClk cycles (466 ms to 1048 ms) after CLK\_IN is removed (see Figure 8). This is true as long as CLK\_IN does not glitch or have an effective change in period as the clock source is removed, otherwise the PLL will interpret this as a change in frequency causing clock skipping and the  $2^{23}$  SysClk cycle time-out to be bypassed and the PLL to immediately unlock. If the prior conditions are met while CLK\_IN is removed and  $2^{23}$  SysClk cycles pass, the PLL will unlock and the PLL\_OUT state will be determined by the *ClkOutUnl* bit; See “PLL Clock Output” on page 20. If CLK\_IN is re-applied after such time, the PLL will remain unlocked for the specified

time listed in the “AC Electrical Characteristics” on page 7 after which lock will be acquired and the PLL output will resume.

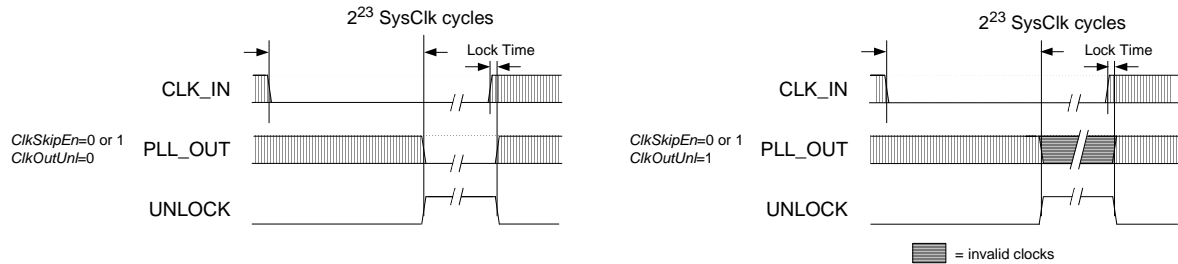

**Figure 8. CLK\_IN removed for > 2<sup>23</sup> SysClk cycles**

If CLK\_IN is removed and then reapplied within 2<sup>23</sup> SysClk cycles but later than  $t_{CS}$ , the *ClkSkipEn* bit will have no effect and the PLL output will continue until CLK\_IN is re-applied (see Figure 9). Once CLK\_IN is re-applied, the PLL will go unlocked only for the time it takes to acquire lock; the PLL\_OUT state will be determined by the *ClkOutUnl* bit during this time.

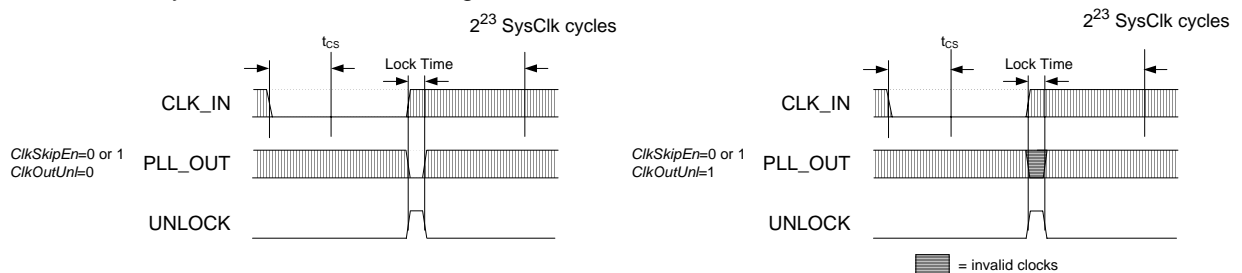

**Figure 9. CLK\_IN removed for < 2<sup>23</sup> SysClk cycles but >  $t_{CS}$**

If CLK\_IN is removed and then re-applied within  $t_{CS}$ , the *ClkSkipEn* bit determines whether PLL\_OUT continues while the PLL re-acquires lock (see Figure 10). When *ClkSkipEn* is disabled and CLK\_IN is removed the PLL output will continue until CLK\_IN is re-applied at which point the PLL will go unlocked only for the time it takes to acquire lock; the PLL\_OUT state will be determined by the *ClkOutUnl* bit during this time. When *ClkSkipEn* is enabled and CLK\_IN is removed the PLL output clock will remain continuous throughout the missing CLK\_IN period including the time while the PLL re-acquires lock.

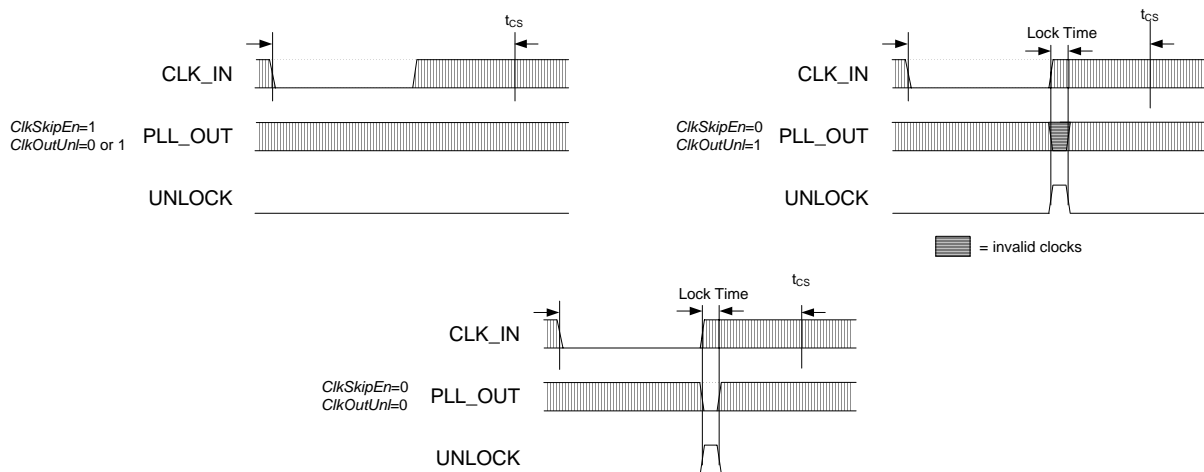

**Figure 10. CLK\_IN removed for <  $t_{CS}$**

Referenced Control	Register Location
ClkSkipEn.....	“Clock Skip Enable (ClkSkipEn)” on page 28
ClkOutUnl.....	“Enable PLL Clock Output on Unlock (ClkOutUnl)” on page 29

### 5.2.3 Adjusting the Minimum Loop Bandwidth for CLK\_IN

The CS2000 allows the minimum loop bandwidth of the Digital PLL to be adjusted between 1 Hz and 128 Hz using the *ClkIn\_BW[2:0]* bits. The minimum loop bandwidth of the Digital PLL directly affects the jitter transfer function; specifically, jitter frequencies below the loop bandwidth corner are passed from the PLL input directly to the PLL output without attenuation. In some applications it is desirable to have a very low minimum loop bandwidth to reject very low jitter frequencies, commonly referred to as wander. In others it may be preferable to remove only higher frequency jitter, allowing the input wander to pass through the PLL without attenuation.

Typically, applications in which the PLL\_OUT signal creates a new clock domain from which all other system clocks and associated data are derived will benefit from the maximum jitter and wander rejection of the lowest PLL bandwidth setting. See [Figure 11](#).

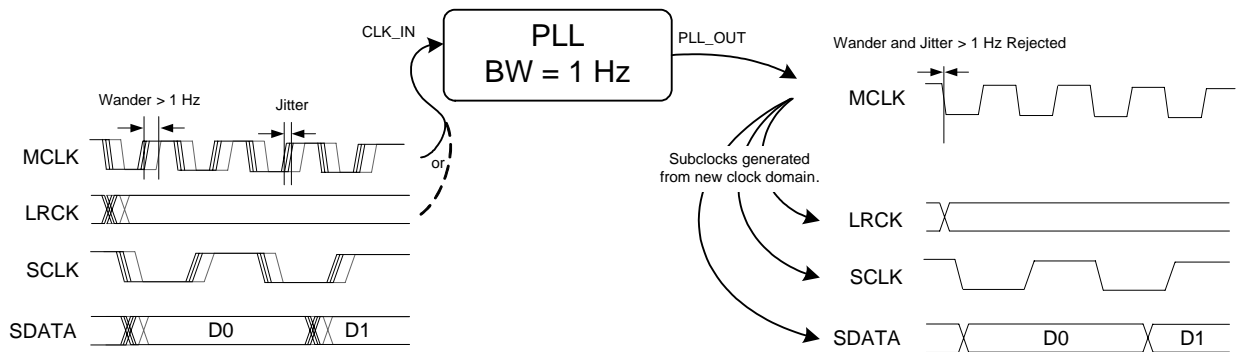

**Figure 11. Low bandwidth and new clock domain**

Systems in which some clocks and data are derived from the PLL\_OUT signal while other clocks and data are derived from the CLK\_IN signal will often require phase alignment of all the clocks and data in the system. See [Figure 12](#). If there is substantial wander on the CLK\_IN signal in these applications, it may be necessary to increase the minimum loop bandwidth allowing this wander to pass through to the CLK\_OUT signal in order to maintain phase alignment. For these applications, it is advised to experiment with the loop bandwidth settings and choose the lowest bandwidth setting that does not produce system timing errors due to wandering between the clocks and data synchronous to the CLK\_IN domain and those synchronous to the PLL\_OUT domain.

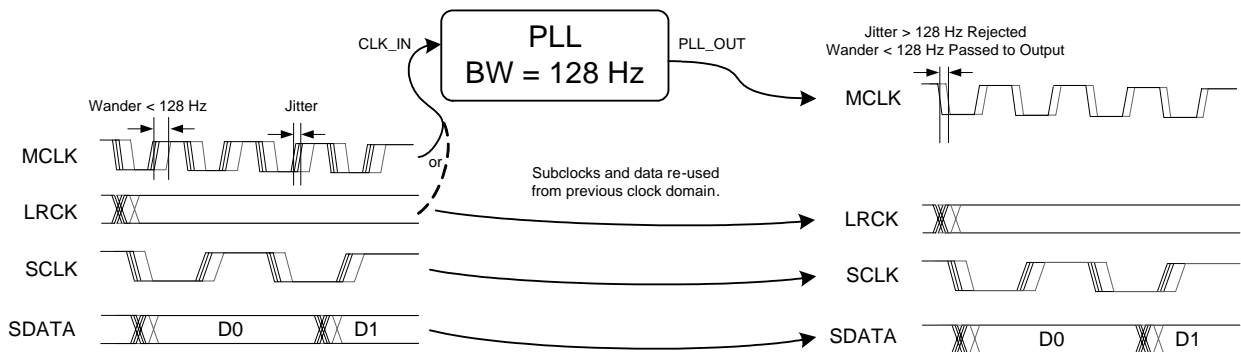

**Figure 12. High bandwidth with CLK\_IN domain re-use**

It should be noted that manual adjustment of the minimum loop bandwidth is not necessary to acquire lock; this adjustment is made automatically by the Digital PLL. While acquiring lock, the digital loop bandwidth is automatically set to a large value. Once lock is achieved, the digital loop bandwidth will settle to the minimum value selected by the *ClkIn\_BW[2:0]* bits.

Referenced Control	Register Location
<i>ClkIn_BW[2:0]</i> .....	"Clock Input Bandwidth ( <i>ClkIn_BW[2:0]</i> )" on page 29

### 5.3 Output to Input Frequency Ratio Configuration

#### 5.3.1 User Defined Ratio ( $R_{UD}$ )

The User Defined Ratio,  $R_{UD}$ , is a 32-bit un-signed fixed-point number, stored in the *Ratio* register set, which determines the basis for the desired input to output clock ratio. The 32-bit  $R_{UD}$  can be expressed in either a high resolution (12.20) or high multiplication (20.12) format selectable by the *LFRatioCfg* bit, with 20.12 being the default.

The  $R_{UD}$  for high resolution (12.20) format is encoded with 12 MSBs representing the integer binary portion with the remaining 20 LSBs representing the fractional binary portion. The maximum multiplication factor is approximately 4096 with a resolution of 0.954 PPM in this configuration. See [“Calculating the User Defined Ratio” on page 30](#) for more information.

The  $R_{UD}$  for high multiplication (20.12) format is encoded with 20 MSBs representing the integer binary portion with the remaining 12 LSBs representing the fractional binary portion. In this configuration, the maximum multiplication factor is approximately 1,048,575 with a resolution of 244 PPM. It is recommended that the 12.20 High-Resolution format be utilized whenever the desired ratio is less than 4096 since the output frequency accuracy of the PLL is directly proportional to the accuracy of the timing reference clock and the resolution of the  $R_{UD}$ .

The status of internal dividers, such as the internal timing reference clock divider, are automatically taken into account. Therefore  $R_{UD}$  is simply the desired ratio of the output to input clock frequencies.

Referenced Control	Register Location
Ratio.....	<a href="#">“Ratio (Address 06h - 09h)” on page 28</a>
LFRatioCfg.....	<a href="#">“Low-Frequency Ratio Configuration (LFRatioCfg)” on page 29</a>



### 5.3.2 Manual Ratio Modifier (R-Mod)

The manual Ratio Modifier is used to internally multiply/divide the  $R_{UD}$  (the *Ratio* stored in the register space remains unchanged). The available options for  $R_{MOD}$  are summarized in [Table 2 on page 17](#).

The R-Mod value selected by  $RModSel[2:0]$  is always used in the calculation for the Effective Ratio ( $R_{EFF}$ ), see [“Effective Ratio \(REFF\)” on page 18](#). If R-Mod is not desired,  $RModSel[2:0]$  should be left at its default value of ‘000’, which corresponds to an R-Mod value of 1, thereby effectively disabling the ratio modifier.

<b>RModSel[2:0]</b>	<b>Ratio Modifier</b>
000	1
001	2
010	4
011	8
100	0.5
101	0.25
110	0.125
111	0.0625

**Table 2. Ratio Modifier**

<b>Referenced Control</b>	<b>Register Location</b>
Ratio.....	“Ratio (Address 06h - 09h)” on page 28
RModSel[2:0] .....	“R-Mod Selection (RModSel[2:0])” section on page 26

### 5.3.3 Automatic Ratio Modifier (Auto R-Mod)

The Automatic R-Modifier uses the status of the CLK\_IN Frequency Range Indicator (see [section 5.2.1 on page 13](#)) to implement a frequency dependent multiply of the currently addressed  $R_{UD}$  as shown in [Table 3](#).

Like with R-Mod, the *Ratio* stored in the register space remain unchanged. The Automatic Ratio-Modifier is enabled by the *AutoRMod* bit.

<b>FsDetect[1:0]</b>	<b><math>f_{SysClk} / f_{CLK\_IN}</math></b>	<b>Auto R Modifier</b>
00	> 224	1
01	96 - 224	0.5
10	< 96	0.25

**Table 3. Automatic Ratio Modifier**

It is important to note that Auto R-Mod (if enabled) is applied in addition to any R-Mod already selected by the  $RModSel[2:0]$  bits and is used to calculate the Effective Ratio (see [Section 5.3.4 on page 18](#)).

Auto R-Mod can be used to generate the appropriate oversampling clock (MCLK) for audio A/D and D/A converters. For example, if the clock applied to CLK\_IN is the audio sample rate,  $F_s$  (also known as the word, frame or Left/Right clock), and SysClk is 12.288 MHz ( $REF\_CLK = 12.288$  MHz with  $RefClkDiv[1:0]$ )

set to 10), the Frequency Range Indicator would then reflect the frequency range of the audio sample rate. An  $R_{UD}$  of 512 would then generate the audio oversampling clocks as shown in [Table 4](#).

<b>FsDetect[1:0]</b>	<b>Inferred Audio Sample Rate when SysClk=12.288 MHz</b>	<b>Speed Mode (used for audio converters)</b>	<b>Audio Oversampling Clock</b>
00	< 54.8 kHz	Single Speed	512 x
01	54.8 kHz to 128 kHz	Double Speed	256 x
10	> 128 kHz	Quad Speed	128 x

**Table 4. Example Audio Oversampling Clock Generation from CLK\_IN**

<b>Referenced Control</b>	<b>Register Location</b>
Ratio.....	"Ratio (Address 06h - 09h)" on page 28
RModSel[2:0] .....	"R-Mod Selection (RModSel[2:0])" section on page 26
AutoRMod .....	"Auto R-Modifier Enable (AutoRMod)" on page 26

### 5.3.4 Effective Ratio ( $R_{EFF}$ )

The Effective Ratio ( $R_{EFF}$ ) is an internal calculation comprised of  $R_{UD}$  and the appropriate modifiers, as previously described.  $R_{EFF}$  is calculated as follows:

$$R_{EFF} = R_{UD} \cdot R_{MOD} \cdot \text{Auto R-Mod}$$

To simplify operation the device handles some of the ratio calculation functions automatically (such as when the internal timing reference clock divider is set). For this reason, the Effective Ratio does not need to be altered to account for internal dividers.

Ratio modifiers which would produce an overflow or truncation of  $R_{EFF}$  should not be used; For example if  $R_{UD}$  is 1024 an  $R_{MOD}$  of 8 would produce an  $R_{EFF}$  value of 8192 which exceeds the 4096 limit of the 12.20 format. In all cases, the maximum and minimum allowable values for  $R_{EFF}$  are dictated by the frequency limits for both the input and output clocks as shown in the ["AC Electrical Characteristics"](#) on [page 7](#).

### 5.3.5 Ratio Configuration Summary

The  $R_{UD}$  is the user defined ratio stored in the register space. The resolution for the  $R_{UD}$  is selectable by setting *LFRatioCfg*. R-Mod is applied if selected. The user defined ratio, ratio modifier, and automatic ratio modifier make up the effective ratio  $R_{EFF}$ , the final calculation used to determine the output to input clock ratio. The effective ratio is then corrected for the internal dividers. The conceptual diagram in [Figure 13](#) summarizes the features involved in the calculation of the ratio values used to generate the fractional-N value which controls the Frequency Synthesizer.

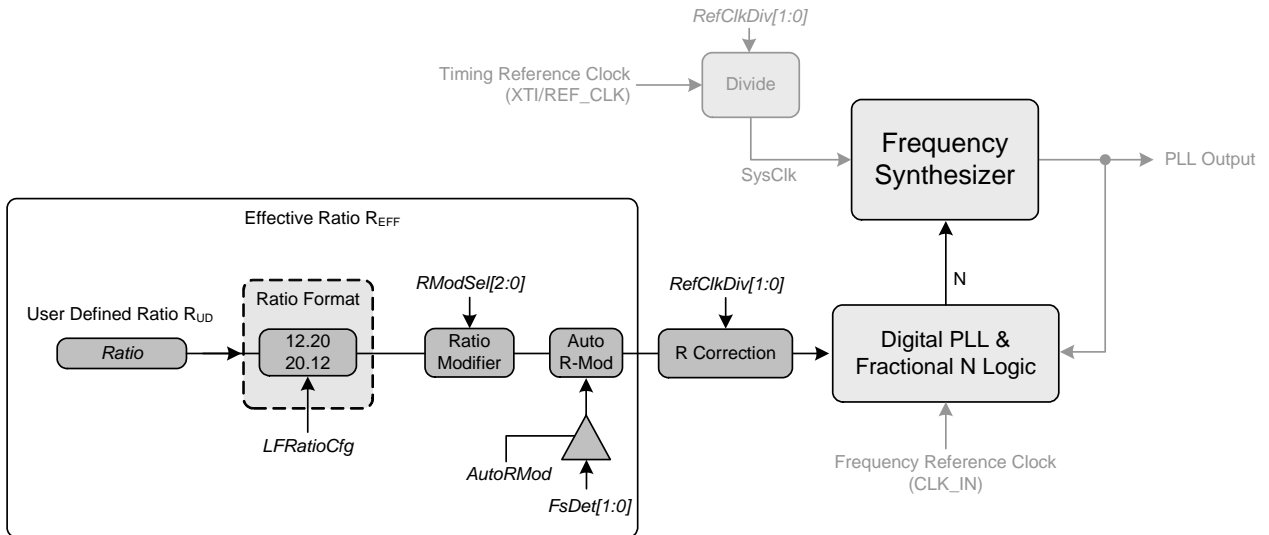

**Figure 13. Ratio Feature Summary**

Referenced Control	Register Location
Ratio	"Ratio (Address 06h - 09h)" on page 28
LFRatioCfg	"Low-Frequency Ratio Configuration (LFRatioCfg)" on page 29
RModSel[2:0]	"R-Mod Selection (RModSel[2:0])" section on page 26
AutoRMod	"Auto R-Modifier Enable (AutoRMod)" on page 26
FsDet[1:0]	"PLL Input Sample Rate Indicator (FsDet[1:0]) - Read Only" section on page 25
RefClkDiv[1:0]	"Reference Clock Input Divider (RefClkDiv[1:0])" on page 28

## 5.4 PLL Clock Output

The PLL clock output pin (CLK\_OUT) provides a buffered version of the output of the frequency synthesizer. The driver can be set to high-impedance with the *ClkOutDis* bit.

The output from the PLL automatically drives a static low condition while the PLL is un-locked (when the clock may be unreliable). This feature can be disabled by setting the *ClkOutUnl* bit, however the state CLK\_OUT may then be unreliable during an unlock condition.

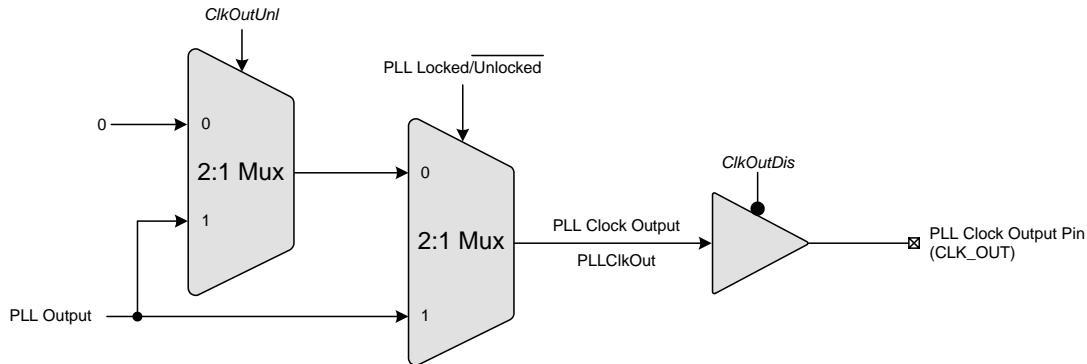
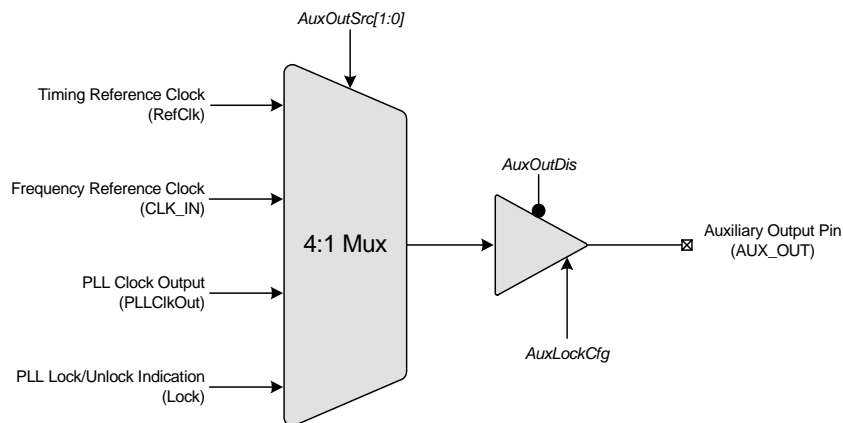

**Figure 14. PLL Clock Output Options**

Referenced Control	Register Location
ClkOutUnl.....	“Enable PLL Clock Output on Unlock (ClkOutUnl)” on page 29
ClkOutDis.....	“PLL Clock Output Disable (ClkOutDis)” on page 26

## 5.5 Auxiliary Output

The auxiliary output pin (AUX\_OUT) can be mapped, as shown in [Figure 15](#), to one of four signals: reference clock (RefClk), input clock (CLK\_IN), additional PLL clock output (CLK\_OUT), or a PLL lock indicator (Lock). The mux is controlled via the *AuxOutSrc[1:0]* bits. If AUX\_OUT is set to Lock, the *AuxLockCfg* bit is then used to control the output driver type and polarity of the LOCK signal (see [section 8.6.2 on page 28](#)). If AUX\_OUT is set to CLK\_OUT the phase of the PLL Clock Output signal on AUX\_OUT may differ from the CLK\_OUT pin. The driver for the pin can be set to high-impedance using the *AuxOutDis* bit.



**Figure 15. Auxiliary Output Selection**

Referenced Control	Register Location
AuxOutSrc[1:0].....	“Auxiliary Output Source Selection (AuxOutSrc[1:0])” on page 27
AuxOutDis.....	“Auxiliary Output Disable (AuxOutDis)” on page 26
AuxLockCfg.....	“AUX PLL Lock Output Configuration (AuxLockCfg)” section on page 28

## 5.6 Clock Output Stability Considerations

### 5.6.1 Output Switching

CS2100 is designed such that re-configuration of the clock routing functions do not result in a partial clock period on any of the active outputs (CLK\_OUT and/or AUX\_OUT). In particular, enabling or disabling an output, changing the auxiliary output source between REF\_CLK and CLK\_OUT, and the automatic disabling of the output(s) during unlock will not cause a runt or partial clock period.

The following exceptions/limitations exist:

- Enabling/disabling AUX\_OUT when AuxOutSrc = 11 (unlock indicator).
- Switching AuxOutSrc[1:0] to or from 01 (PLL clock input) and to or from 11 (unlock indicator) (Transitions between AuxOutSrc[1:0] = [00,10] will not produce a glitch).
- Changing the *ClkOutUnl* bit while the PLL is in operation.

When any of these exceptions occur, a partial clock period on the output may result.

### 5.6.2 PLL Unlock Conditions

Certain changes to the clock inputs and registers can cause the PLL to lose lock which will affect the presence the clock signal on CLK\_OUT. The following outlines which conditions cause the PLL to go unlocked:

- Changes made to the registers which affect the Fraction-N value that is used by the Frequency Synthesizer. This includes all the bits shown in [Figure 13 on page 19](#).
- Any discontinuities on the Timing Reference Clock, REF\_CLK.
- Discontinuities on the Frequency Reference Clock, CLK\_IN, except when the Clock Skipping feature is enabled and the requirements of Clock Skipping are satisfied (see "[CLK\\_IN Skipping Mode](#)" on [page 13](#)).
- Gradual changes in CLK\_IN frequency greater than  $\pm 30\%$  from the starting frequency.
- Step changes in CLK\_IN frequency.

## 6. SPI / I<sup>2</sup>C CONTROL PORT

The control port is used to access the registers and allows the device to be configured for the desired operational modes and formats. The operation of the control port may be completely asynchronous with respect to device inputs and outputs. However, to avoid potential interference problems, the control port pins should remain static if no operation is required.

The control port operates with either the SPI or I<sup>2</sup>C interface, with the CS2100 acting as a slave device. SPI Mode is selected if there is a high-to-low transition on the AD0/ $\overline{CS}$  pin after power-up. I<sup>2</sup>C Mode is selected by connecting the AD0/ $\overline{CS}$  pin through a resistor to VD or GND, thereby permanently selecting the desired AD0 bit address state. In both modes the *EnDevCfg1* and *EnDevCfg2* bits must be set to 1 for normal operation.

**WARNING:** All “Reserved” registers must maintain their default state to ensure proper functional operation.

Referenced Control	Register Location
EnDevCfg1 .....	“Enable Device Configuration Registers 1 (EnDevCfg1)” on page 27
EnDevCfg2 .....	“Enable Device Configuration Registers 2 (EnDevCfg2)” section on page 27

### 6.1 SPI Control

In SPI Mode,  $\overline{CS}$  is the chip select signal; CCLK is the control port bit clock (sourced from a microcontroller), and CDIN is the input data line from the microcontroller. Data is clocked in on the rising edge of CCLK. The device only supports write operations.

Figure 16 shows the operation of the control port in SPI Mode. To write to a register, bring  $\overline{CS}$  low. The first eight bits on CDIN form the chip address and must be 10011110. The next eight bits form the Memory Address Pointer (MAP), which is set to the address of the register that is to be updated. The next eight bits are the data which will be placed into the register designated by the MAP.

There is MAP auto increment capability, enabled by the INCR bit in the MAP register. If INCR is a zero, the MAP will stay constant for successive read or writes. If INCR is set to a 1, the MAP will automatically increment after each byte is read or written, allowing block writes of successive registers.

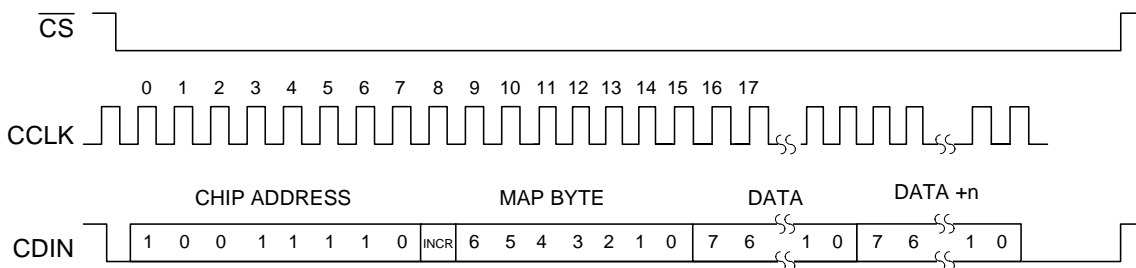

Figure 16. Control Port Timing in SPI Mode

### 6.2 I<sup>2</sup>C Control

In I<sup>2</sup>C Mode, SDA is a bidirectional data line. Data is clocked into and out of the device by the clock, SCL. There is no  $\overline{CS}$  pin. The AD0 pin forms the least-significant bit of the chip address and should be connected to VD or GND as appropriate. The state of the AD0 pin should be maintained throughout operation of the device.

The signal timings for a read and write cycle are shown in Figure 17 and Figure 18. A Start condition is defined as a falling transition of SDA while the clock is high. A Stop condition is a rising transition while the clock is high. All other transitions of SDA occur while the clock is low. The first byte sent to the CS2100 after a Start condition consists of the 7-bit chip address field and a R/W bit (high for a read, low for a write). The upper 6 bits of the 7-bit address field are fixed at 100111 followed by the logic state of the AD0 pin. The

eighth bit of the address is the R/W bit. If the operation is a write, the next byte is the Memory Address Pointer (MAP) which selects the register to be read or written. If the operation is a read, the contents of the register pointed to by the MAP will be output. Setting the auto increment bit in MAP allows successive reads or writes of consecutive registers. Each byte is separated by an acknowledge bit. The ACK bit is output from the CS2100 after each input byte is read and is input from the microcontroller after each transmitted byte.

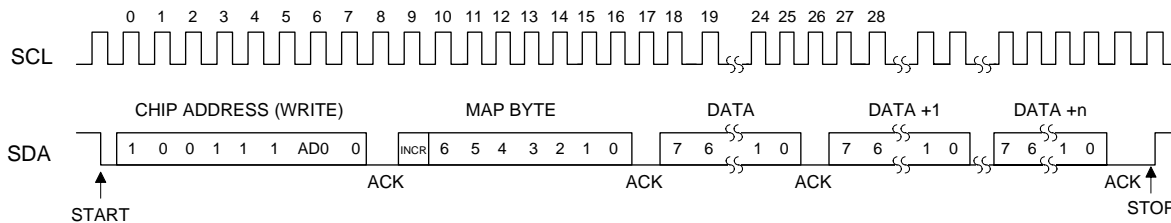

**Figure 17. Control Port Timing, I<sup>2</sup>C Write**

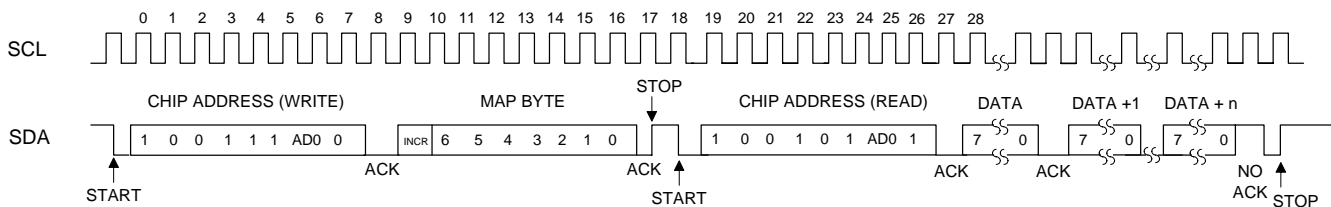

**Figure 18. Control Port Timing, I<sup>2</sup>C Aborted Write + Read**

Since the read operation cannot set the MAP, an aborted write operation is used as a preamble. As shown in [Figure 17](#), the write operation is aborted after the acknowledge for the MAP byte by sending a stop condition. The following pseudocode illustrates an aborted write operation followed by a read operation.

- Send start condition.
- Send 100111x0 (chip address & write operation).
- Receive acknowledge bit.
- Send MAP byte, auto increment off.
- Receive acknowledge bit.
- Send stop condition, aborting write.
- Send start condition.
- Send 100111x1(chip address & read operation).
- Receive acknowledge bit.
- Receive byte, contents of selected register.
- Send acknowledge bit.
- Send stop condition.

Setting the auto increment bit in the MAP allows successive reads or writes of consecutive registers. Each byte is separated by an acknowledge bit.

### 6.3 Memory Address Pointer

The Memory Address Pointer (MAP) byte comes after the address byte and selects the register to be read or written. Refer to the pseudocode above for implementation details.

#### 6.3.1 Map Auto Increment

The device has MAP auto increment capability enabled by the INCR bit (the MSB) of the MAP. If INCR is set to 0, MAP will stay constant for successive I<sup>2</sup>C writes or reads and SPI writes. If INCR is set to 1, MAP will auto increment after each byte is read or written, allowing block reads or writes of successive registers.

## 7. REGISTER QUICK REFERENCE

This table shows the register and bit names with their associated default values. *EnDevCfg1* and *EnDevCfg2* bits must be set to 1 for normal operation.

**WARNING:** All “Reserved” registers must maintain their default state to ensure proper functional operation.

Adr	Name	7	6	5	4	3	2	1	0
01h p 25	Device ID	Device4 0	Device3 0	Device2 0	Device1 0	Device0 0	Revision2 x	Revision1 x	Revision0 x
02h p 25	Device Ctrl	Unlock x	FsDet1 x	FsDet0 x	Reserved 0	AutoRMod 0	Reserved 0	AuxOutDis 0	ClkOutDis 0
03h p 26	Device Cfg 1	RModSel2 0	RModSel1 0	RModSel0 0	Reserved 0	Reserved 0	AuxOutSrc1 0	AuxOutSrc0 0	EnDevCfg1 0
05h p 27	Global Cfg	Reserved 0	Reserved 0	Reserved 0	Reserved 0	Freeze 0	Reserved 0	Reserved 0	EnDevCfg2 0
06h - 09h	32-Bit Ratio	MSB ..... MSB-8 ..... LSB+15 ..... LSB+7 .....							MSB-7 MSB-15 LSB+8 LSB
16h p 28	Funct Cfg 1	ClkSkipEn 0	AuxLockCfg 0	Reserved 0	RefClkDiv1 0	RefClkDiv0 0	Reserved 0	Reserved 0	Reserved 0
17h p 29	Funct Cfg 2	Reserved 0	Reserved 0	Reserved 0	ClkOutUnl 0	LFRatioCfg 0	Reserved 0	Reserved 0	Reserved 0
1Eh p 29	Funct Cfg 3	Reserved 0	ClkIn_BW2 0	ClkIn_BW1 0	ClkIn_BW0 0	Reserved 0	Reserved 0	Reserved 0	Reserved 0



## 8. REGISTER DESCRIPTIONS

In I<sup>2</sup>C Mode all registers are read/write unless otherwise stated. In SPI mode all registers are write only. All “Reserved” registers must maintain their default state to ensure proper functional operation. The default state of each bit after a power-up sequence or reset is indicated by the shaded row in the bit decode table and in the [“Register Quick Reference” on page 24](#).

Control port mode is entered when the device recognizes a valid chip address input on its I<sup>2</sup>C/SPI serial control pins and the *EnDevCfg1* and *EnDevCfg2* bits are set to 1.

### 8.1 Device I.D. and Revision (Address 01h)

7	6	5	4	3	2	1	0
Device4	Device3	Device2	Device1	Device0	Revision2	Revision1	Revision0

#### 8.1.1 Device Identification (Device[4:0]) - Read Only

I.D. code for the CS2100.

Device[4:0]	Device
00000	CS2100.

#### 8.1.2 Device Revision (Revision[2:0]) - Read Only

CS2100 revision level.

REVID[2:0]	Revision Level
100	B2.

### 8.2 Device Control (Address 02h)

7	6	5	4	3	2	1	0
Unlock	FsDet1	FsDet0	Reserved	AutoRMod	Reserved	AuxOutDis	ClkOutDis

#### 8.2.1 Unlock Indicator (Unlock) - Read Only

Indicates the lock state of the PLL.

Unlock	PLL Lock State
0	PLL is Locked.
1	PLL is Unlocked.

#### 8.2.2 PLL Input Sample Rate Indicator (FsDet[1:0]) - Read Only

Indicates the range of the frequency of CLK\_IN relative to the frequency of SysClk. For audio applications, this can be used to distinguish single-, double-, and quad-speed modes.

FsDet[1:0]	$f_{\text{SysClk}} / f_{\text{CLK\_IN}}$
00	> 224.
01	96 to 224.
10	< 96.
11	Reserved.
<b>Application:</b>	<a href="#">“CLK_IN Frequency Detector” on page 13</a>

### 8.2.3 *Auto R-Modifier Enable (AutoRMod)*

Controls the automatic ratio modifier function.

AutoRMod	Automatic R-Mod State
0	Disabled.
1	Enabled.
<b>Application:</b>	<a href="#">“Automatic Ratio Modifier (Auto R-Mod)” on page 17</a>

### 8.2.4 *Auxiliary Output Disable (AuxOutDis)*

This bit controls the output driver for the AUX\_OUT pin.

AuxOutDis	Output Driver State
0	AUX_OUT output driver enabled.
1	AUX_OUT output driver set to high-impedance.
<b>Application:</b>	<a href="#">“Auxiliary Output” on page 20</a>

### 8.2.5 *PLL Clock Output Disable (ClkOutDis)*

This bit controls the output driver for the CLK\_OUT pin.

ClkOutDis	Output Driver State
0	CLK_OUT output driver enabled.
1	CLK_OUT output driver set to high-impedance.
<b>Application:</b>	<a href="#">“PLL Clock Output” on page 20</a>

## 8.3 *Device Configuration 1 (Address 03h)*

7	6	5	4	3	2	1	0
RModSel2	RModSel1	RModSel0	Reserved	Reserved	AuxOutSrc1	AuxOutSrc0	EnDevCfg1

### 8.3.1 *R-Mod Selection (RModSel[2:0])*

Selects the R-Mod value, which is used as a factor in determining the PLL's Fractional N.

RModSel[2:0]	R-Mod Selection
000	Left-shift R-value by 0 (x 1).
001	Left-shift R-value by 1 (x 2).
010	Left-shift R-value by 2 (x 4).
011	Left-shift R-value by 3 (x 8).
100	Right-shift R-value by 1 ( $\div 2$ ).
101	Right-shift R-value by 2 ( $\div 4$ ).
110	Right-shift R-value by 3 ( $\div 8$ ).
111	Right-shift R-value by 4 ( $\div 16$ ).
<b>Application:</b>	<a href="#">“Manual Ratio Modifier (R-Mod)” on page 17</a>

### 8.3.2 Auxiliary Output Source Selection (*AuxOutSrc[1:0]*)

Selects the source of the AUX\_OUT signal.

<i>AuxOutSrc[1:0]</i>	Auxiliary Output Source
00	RefClk.
01	CLK_IN.
10	CLK_OUT.
11	PLL Lock Status Indicator.
<b>Application:</b>	<a href="#">"Auxiliary Output" on page 20</a>

**Note:** When set to 11, *AuxLckCfg* sets the polarity and driver type ("[AUX PLL Lock Output Configuration \(AuxLockCfg\)](#)" on page 28).

### 8.3.3 Enable Device Configuration Registers 1 (*EnDevCfg1*)

This bit, in conjunction with *EnDevCfg2*, enables control port mode. Both bits must be set to 1 during initialization.

<i>EnDevCfg1</i>	Register State
0	Disabled.
1	Enabled.
<b>Application:</b>	<a href="#">"SPI / I<sup>2</sup>C Control Port" on page 22</a>

**Note:** *EnDevCfg2* must also be set to enable control port mode ("[SPI / I<sup>2</sup>C Control Port" on page 22](#)).

## 8.4 Global Configuration (Address 05h)

7	6	5	4	3	2	1	0
Reserved	Reserved	Reserved	Reserved	Freeze	Reserved	Reserved	<i>EnDevCfg2</i>

### 8.4.1 Device Configuration Freeze (*Freeze*)

Setting this bit allows writes to the Device Control and Device Configuration registers (address 02h - 04h) but keeps them from taking effect until this bit is cleared.

<i>FREEZE</i>	Device Control and Configuration Registers
0	Register changes take effect immediately.
1	Modifications may be made to Device Control and Device Configuration registers (registers 02h-04h) without the changes taking effect until after the <i>FREEZE</i> bit is cleared.

### 8.4.2 Enable Device Configuration Registers 2 (*EnDevCfg2*)

This bit, in conjunction with *EnDevCfg1*, enables control port mode. Both bits must be set to 1 during initialization.

<i>EnDevCfg2</i>	Register State
0	Disabled.
1	Enabled.
<b>Application:</b>	<a href="#">"SPI / I<sup>2</sup>C Control Port" on page 22</a>

**Note:** *EnDevCfg1* must also be set to enable control port mode ("[SPI / I<sup>2</sup>C Control Port" on page 22](#)).

## 8.5 Ratio (Address 06h - 09h)

	7	6	5	4	3	2	1	0
MSB	.....							MSB-7
MSB-8	.....							MSB-15
LSB+15	.....							LSB+8
LSB+7	.....							LSB

These registers contain the User Defined Ratio as shown in the “[Register Quick Reference](#)” section on [page 24](#). These 4 registers form a single 32-bit ratio value as shown above. See “[Output to Input Frequency Ratio Configuration](#)” on [page 16](#) and “[Calculating the User Defined Ratio](#)” on [page 30](#) for more details.

## 8.6 Function Configuration 1 (Address 16h)

	7	6	5	4	3	2	1	0
ClkSkipEn	AuxLockCfg	Reserved	RefClkDiv1	RefClkDiv0	Reserved	Reserved	Reserved	Reserved

### 8.6.1 Clock Skip Enable (ClkSkipEn)

This bit enables clock skipping mode for the PLL and allows the PLL to maintain lock even when the CLK\_IN has missing pulses.

ClkSkipEn	PLL Clock Skipping Mode
0	Disabled.
1	Enabled.
<b>Application:</b>	“ <a href="#">CLK_IN Skipping Mode</a> ” on <a href="#">page 13</a>

**Note:**  $f_{CLK\_IN}$  must be < 80 kHz to use this feature.

### 8.6.2 AUX PLL Lock Output Configuration (AuxLockCfg)

When the AUX\_OUT pin is configured as a lock indicator ( $AuxOutSrc[1:0] = 11$ ), this bit configures the AUX\_OUT driver to either push-pull or open drain. It also determines the polarity of the lock signal. If AUX\_OUT is configured as a clock output, the state of this bit is disregarded.

AuxLockCfg	AUX_OUT Driver Configuration
0	Push-Pull, Active High (output ‘high’ for unlocked condition, ‘low’ for locked condition).
1	Open Drain, Active Low (output ‘low’ for unlocked condition, high-Z for locked condition).
<b>Application:</b>	“ <a href="#">Auxiliary Output</a> ” on <a href="#">page 20</a>

**Note:** AUX\_OUT is an **unlock** indicator, signalling an error condition when the PLL is unlocked. Therefore, the pin polarity is defined relative to the **unlock** condition.

### 8.6.3 Reference Clock Input Divider (RefClkDiv[1:0])

Selects the input divider for the timing reference clock.

RefClkDiv[1:0]	Reference Clock Input Divider	REF_CLK Frequency Range
00	÷ 4.	32 MHz to 75 MHz (50 MHz with XTI)
01	÷ 2.	16 MHz to 37.5 MHz
10	÷ 1.	8 MHz to 18.75 MHz
11	Reserved.	
<b>Application:</b>	“ <a href="#">Internal Timing Reference Clock Divider</a> ” on <a href="#">page 12</a>	

## 8.7 Function Configuration 2 (Address 17h)

7	6	5	4	3	2	1	0
Reserved	Reserved	Reserved	ClkOutUnl	LFRatioCfg	Reserved	Reserved	Reserved

### 8.7.1 Enable PLL Clock Output on Unlock (ClkOutUnl)

Defines the state of the PLL output during the PLL unlock condition.

ClkOutUnl	Clock Output Enable Status
0	Clock outputs are driven 'low' when PLL is unlocked.
1	Clock outputs are always enabled (results in unpredictable output when PLL is unlocked).
<b>Application:</b>	<a href="#">"PLL Clock Output" on page 20</a>

### 8.7.2 Low-Frequency Ratio Configuration (LFRatioCfg)

Determines how to interpret the 32-bit User Defined Ratio.

LFRatioCfg	Ratio Bit Encoding Interpretation
0	20.12 - High Multiplier.
1	12.20 - High Accuracy.
<b>Application:</b>	<a href="#">"User Defined Ratio (RUD)" on page 16</a>

## 8.8 Function Configuration 3 (Address 1Eh)

7	6	5	4	3	2	1	0
Reserved	ClkIn_BW2	ClkIn_BW1	ClkIn_BW0	Reserved	Reserved	Reserved	Reserved

### 8.8.1 Clock Input Bandwidth (ClkIn\_BW[2:0])

Sets the minimum loop bandwidth when locked to CLK\_IN.

ClkIn_BW[2:0]	Minimum Loop Bandwidth
000	1 Hz
001	2 Hz
010	4 Hz
011	8 Hz
100	16 Hz
101	32 Hz
110	64 Hz
111	128 Hz
<b>Application:</b>	<a href="#">"Adjusting the Minimum Loop Bandwidth for CLK_IN" on page 15</a>

**Note:** In order to guarantee that a change in minimum bandwidth takes effect, these bits must be set prior to acquiring lock (removing and re-applying CLK\_IN can provide the unlock condition necessary to initiate the setting change). In production systems these bits should be configured with the desired values prior to setting the *EnDevCfg* bits; this guarantees that the setting takes effect prior to acquiring lock.

## 9. CALCULATING THE USER DEFINED RATIO

**Note:** The software for use with the evaluation kit has built in tools to aid in calculating and converting the User Defined Ratio. This section is for those who are not interested in the software or who are developing their systems without the aid of the evaluation kit.

Most calculators do not interpret the fixed point binary representation which the CS2100 uses to define the output to input clock ratio (see [Section 5.3.1 on page 16](#)); However, with a simple conversion we can use these tools to generate a binary or hex value which can be written to the *Ratio* register.

### 9.1 High Resolution 12.20 Format

To calculate the User Defined Ratio ( $R_{UD}$ ) to store in the register(s), divide the desired output clock frequency by the given input clock (CLK\_IN). Then multiply the desired ratio by the scaling factor of  $2^{20}$  to get the scaled decimal representation; then use the decimal to binary/hex conversion function on a calculator and write to the register. A few examples have been provided in [Table 5](#).

Desired Output to Input Clock Ratio (output clock/input clock)	Scaled Decimal Representation = (output clock/input clock) • $2^{20}$	Hex Representation of Binary $R_{UD}$
12.288 MHz/10 MHz=1.2288	1288490	00 13 A9 2A
11.2896 MHz/44.1 kHz=256	268435456	10 00 00 00

**Table 5. Example 12.20 R-Values**

### 9.2 High Multiplication 20.12 Format

To calculate the User Defined Ratio ( $R_{UD}$ ) to store in the register(s), divide the desired output clock frequency by the given input clock (CLK\_IN). Then multiply the desired ratio by the scaling factor of  $2^{12}$  to get the scaled decimal representation; then use the decimal to binary/hex conversion function on a calculator and write to the register. A few examples have been provided in [Table 6](#).

Desired Output to Input Clock Ratio (output clock/input clock)	Scaled Decimal Representation = (output clock/input clock) • $2^{12}$	Hex Representation of Binary $R_{UD}$
12.288 MHz/60 Hz=204,800	838860800	32 00 00 00
11.2896 MHz/59.97 Hz =188254.127...	771088904	2D F5 E2 08

**Table 6. Example 20.12 R-Values**

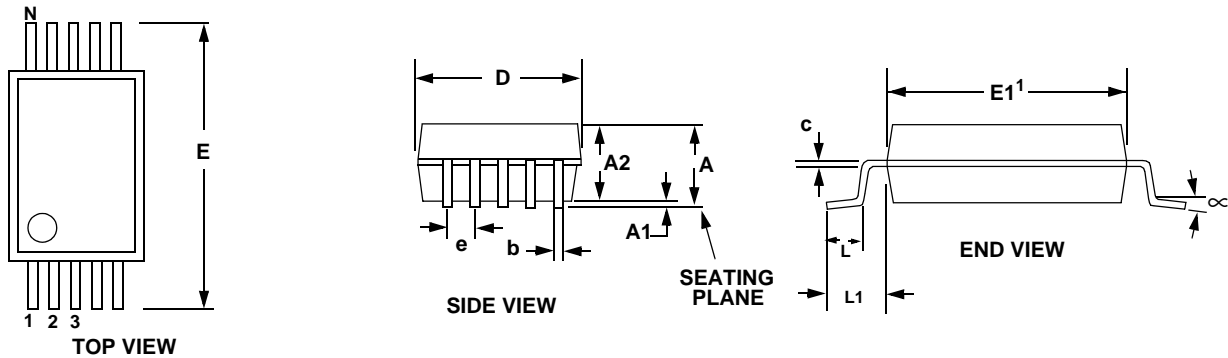
**10.PACKAGE DIMENSIONS**
**10L MSOP (3 mm BODY) PACKAGE DRAWING (Note 1)**

DIM	INCHES			MILLIMETERS			NOTE
	MIN	NOM	MAX	MIN	NOM	MAX	
A	--	--	0.0433	--	--	1.10	
A1	0	--	0.0059	0	--	0.15	
A2	0.0295	--	0.0374	0.75	--	0.95	
b	0.0059	--	0.0118	0.15	--	0.30	4, 5
c	0.0031	--	0.0091	0.08	--	0.23	
D	--	0.1181 BSC	--	--	3.00 BSC	--	2
E	--	0.1929 BSC	--	--	4.90 BSC	--	
E1	--	0.1181 BSC	--	--	3.00 BSC	--	3
e	--	0.0197 BSC	--	--	0.50 BSC	--	
L	0.0157	0.0236	0.0315	0.40	0.60	0.80	
L1	--	0.0374 REF	--	--	0.95 REF	--	

- Notes:**
- Reference document: JEDEC MO-187
  - D does not include mold flash or protrusions which is 0.15 mm max. per side.
  - E1 does not include inter-lead flash or protrusions which is 0.15 mm max per side.
  - Dimension b does not include a total allowable dambar protrusion of 0.08 mm max.
  - Exceptions to JEDEC dimension.

**THERMAL CHARACTERISTICS**

Parameter		Symbol	Min	Typ	Max	Units
Junction to Ambient Thermal Impedance	JEDEC 2-Layer	$\theta_{JA}$	-	170	-	°C/W
	JEDEC 4-Layer	$\theta_{JA}$	-	100	-	°C/W

## 11. ORDERING INFORMATION

Product	Description	Package	Pb-Free	Grade	Temp Range	Container	Order#
CS2100-CP	Clocking Device	10L-MSOP	Yes	Commercial	-10° to +70°C	Rail	CS2100-CP-CZZ
CS2100-CP	Clocking Device	10L-MSOP	Yes		-10° to +70°C	Tape and Reel	CS2100-CP-CZZR
CDK2000	Evaluation Platform	-	Yes	-	-	-	CDK-2000-CLK

## 12. REFERENCES

1. Audio Engineering Society AES-12id-2006: "AES Information Document for digital audio measurements - Jitter performance specifications," May 2007.
2. Philips Semiconductor, "The I<sup>2</sup>C-Bus Specification: Version 2," Dec. 1998.  
<http://www.semiconductors.philips.com>

## 13. REVISION HISTORY

Release	Changes
A1	Initial Release
PP1	Updated "AC Electrical Characteristics" on page 7

## Contacting Cirrus Logic Support

For all product questions and inquiries, contact a Cirrus Logic Sales Representative.  
To find one nearest you, go to [www.cirrus.com](http://www.cirrus.com)

### IMPORTANT NOTICE

"Preliminary" product information describes products that are in production, but for which full characterization data is not yet available.

Cirrus Logic, Inc. and its subsidiaries ("Cirrus") believe that the information contained in this document is accurate and reliable. However, the information is subject to change without notice and is provided "AS IS" without warranty of any kind (express or implied). Customers are advised to obtain the latest version of relevant information to verify, before placing orders, that information being relied on is current and complete. All products are sold subject to the terms and conditions of sale supplied at the time of order acknowledgment, including those pertaining to warranty, indemnification, and limitation of liability. No responsibility is assumed by Cirrus for the use of this information, including use of this information as the basis for manufacture or sale of any items, or for infringement of patents or other rights of third parties. This document is the property of Cirrus and by furnishing this information, Cirrus grants no license, express or implied under any patents, mask work rights, copyrights, trademarks, trade secrets or other intellectual property rights. Cirrus owns the copyrights associated with the information contained herein and gives consent for copies to be made of the information only for use within your organization with respect to Cirrus integrated circuits or other products of Cirrus. This consent does not extend to other copying such as copying for general distribution, advertising or promotional purposes, or for creating any work for resale.

CERTAIN APPLICATIONS USING SEMICONDUCTOR PRODUCTS MAY INVOLVE POTENTIAL RISKS OF DEATH, PERSONAL INJURY, OR SEVERE PROPERTY OR ENVIRONMENTAL DAMAGE ("CRITICAL APPLICATIONS"). CIRRUS PRODUCTS ARE NOT DESIGNED, AUTHORIZED OR WARRANTED FOR USE IN PRODUCTS SURGICALLY IMPLANTED INTO THE BODY, AUTOMOTIVE SAFETY OR SECURITY DEVICES, LIFE SUPPORT PRODUCTS OR OTHER CRITICAL APPLICATIONS. INCLUSION OF CIRRUS PRODUCTS IN SUCH APPLICATIONS IS UNDERSTOOD TO BE FULLY AT THE CUSTOMER'S RISK AND CIRRUS DISCLAIMS AND MAKES NO WARRANTY, EXPRESS, STATUTORY OR IMPLIED, INCLUDING THE IMPLIED WARRANTIES OF MERCHANTABILITY AND FITNESS FOR PARTICULAR PURPOSE, WITH REGARD TO ANY CIRRUS PRODUCT THAT IS USED IN SUCH A MANNER. IF THE CUSTOMER OR CUSTOMER'S CUSTOMER USES OR PERMITS THE USE OF CIRRUS PRODUCTS IN CRITICAL APPLICATIONS, CUSTOMER AGREES, BY SUCH USE, TO FULLY INDEMNIFY CIRRUS, ITS OFFICERS, DIRECTORS, EMPLOYEES, DISTRIBUTORS AND OTHER AGENTS FROM ANY AND ALL LIABILITY, INCLUDING ATTORNEYS' FEES AND COSTS, THAT MAY RESULT FROM OR ARISE IN CONNECTION WITH THESE USES.

Cirrus Logic, Cirrus, and the Cirrus Logic logo designs are trademarks of Cirrus Logic, Inc. All other brand and product names in this document may be trademarks or service marks of their respective owners.

I<sup>2</sup>C is a registered trademark of Philips Semiconductor.

SPI is a trademark of Motorola, Inc.