

Adding Pneumatic Preset Counter Type 497



VARIABLE PILOT SIGNAL

TECHNICAL DATA

- Continuously visible preset
- Integrated pneumatic reset
- 3 or 5-digit display
- Convenient button setting

Using two pneumatic preset counters it is possible to implement pilot signals with values ranging from 1 to 99.999. These counters are especially suitable as controlling elements for semi-automatic or fully automated processes. This applies both to varying preset/setting values and to values which remain the same for a long period.

Display	3 or 5-digit indication of count and preset value, depending on version
Digit height	4 mm
Service pressure	2 ... 8 bar
Air quality	oilfree
Filter pore width	< 40 µm
Operating temperature	0 ... + 60 °C
Connection	hose coupler M5 or rapid-fit connection (depending on version)
Mounting	front panel
Mounting position	horizontal roller axis
Protection class (IEC 144)	IP 40 with hoses connected; for higher degree of protection we recommend clear covers
Count input	adding
Min. pulse length	8 ms
Max. counting frequency	20 Hz
Pulse duty factor	1:1
Reset	- manual with button - by external pneumatic signal, Min. pulse length 180 ms - automatic reset after preset has been reached (only in version with automatic reset)
Reset frequency	max. 1 per 2 s
Signal duration	from when preset has been reached until reset; at 3 bar, counter with automatic reset 300 ... 340 ms

Attention! Minimum time period between last count pulse and pneumatic reset is 50 ms.

Type 497

Technical data

DIMENSIONED DRAWINGS

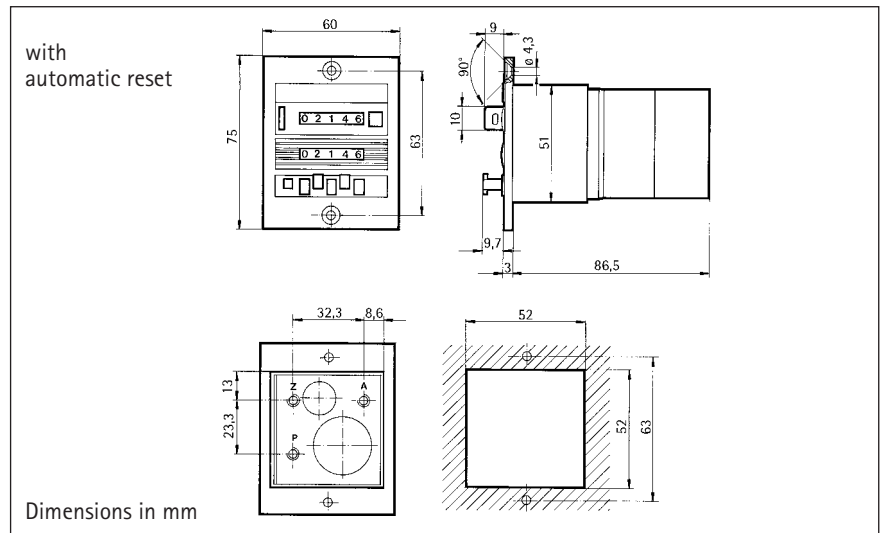
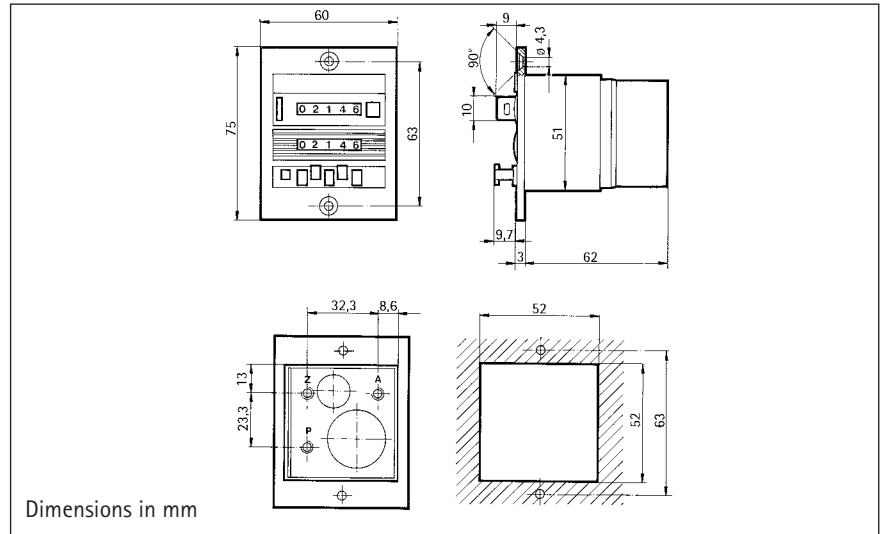

CONNECTION DIAGRAMS

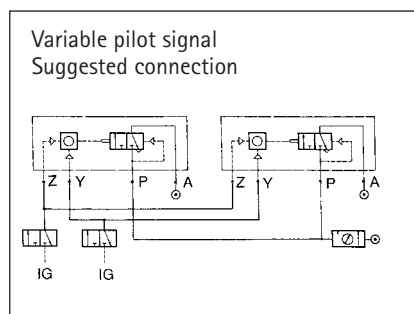
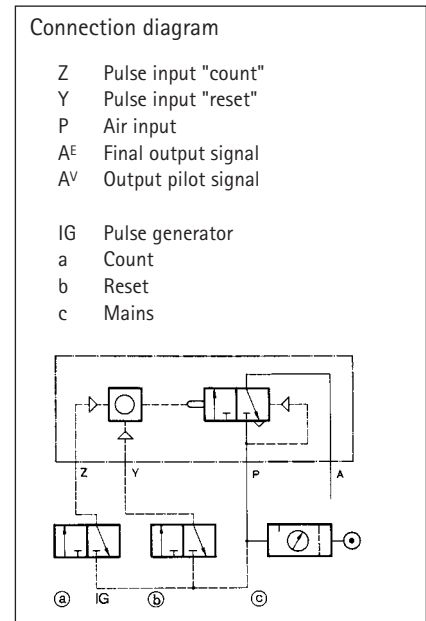
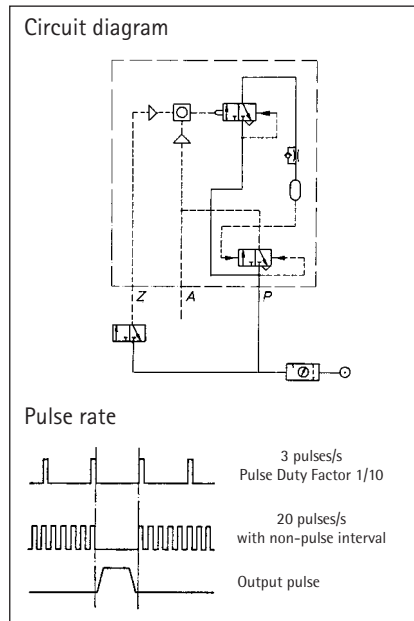

ORDER INFORMATION Counter

Connection	Button and pneum. reset		with automatic reset	
	3-digit	5-digit	3-digit	5-digit
Hose coupler M5	0 497 619	0 497 486	0 497 493	0 497 472
Rapid-fit connector	0 497 618	0 497 487	0 497 479	0 497 473

Standard accessories

Transparent cover (description see "Accessories")				
	with knob			1 405 613
	with lock			1 405 614
Fittings M5 for hose M 5 x 1				3 641 733
Connection kit M5/R 1/8 "				1 495 089*

* on request

Type 497



Subtracting Pneumatic Preset Counter

- Integrated pneumatic reset
- 3 or 5-digit display
- Convenient button setting

TECHNICAL DATA

Display	3 or 5-digit count indication, depending on version
Digit height	4 mm
Service pressure	2 ... 8 bar
Air quality	oilfree
Filter pore width	< 40 µm
Operating temperature	0 ... +60 °C
Connection	hose coupler M5 or rapid-fit connection (depending on version)
Mounting	front panel
Mounting position	horizontal roller axis
Protection class (IEC 144)	IP 40 with hoses connected; for higher degree of protection we recommend clear covers
Count input	subtracting
Min. pulse length	8 ms
Max. counting frequency	20 Hz
Pulse duty factor	1:1
Reset	- manual with button - by external pneumatic signal, Min. pulse length 180 ms
Reset frequency	max. 1 per 2 s
Signal duration	from when preset has been reached until reset; at 6 bar, counter with automatic reset 300 ... 340 ms (depending on connected volume and service pressure)

Attention! Minimum time period between last count pulse and pneumatic reset is 50 ms.

DIMENSIONED DRAWING

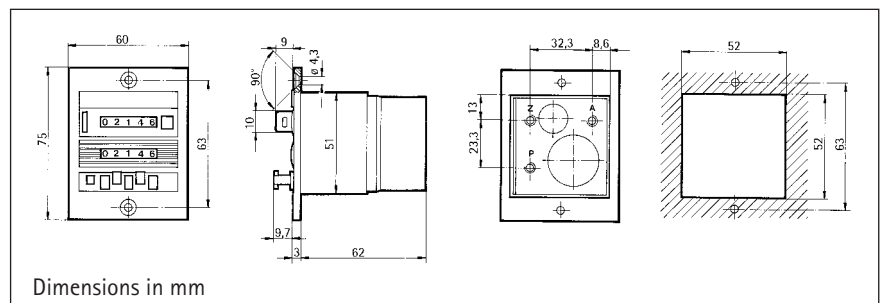

CONNECTION DIAGRAMS

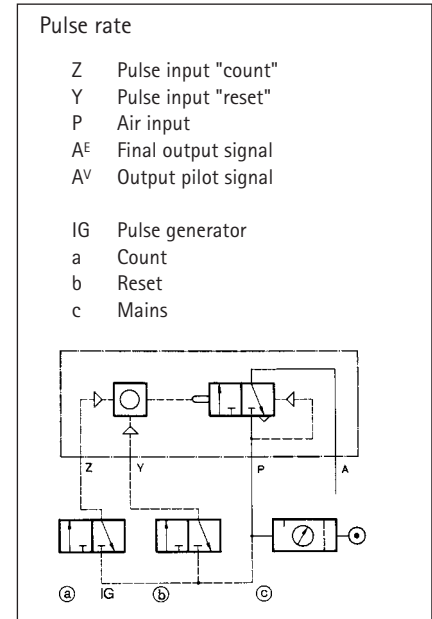
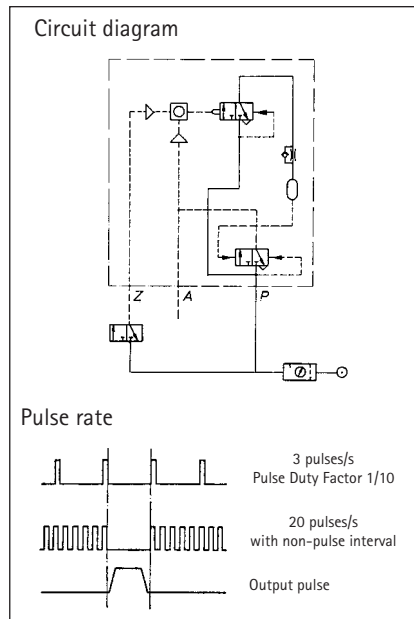

Order information

Counter

Standard accessories

Connection	Button and pneum. reset	
	3-digit	5-digit
Hose coupler M5	0 497 530	0 497 550
Rapid-fit connector	0 497 532	0 497 552
Transparent cover (description see "Accessories")		
with knob		1 405 613
with lock		1 405 614
Fittings M5 for hose M 5 x 1		3 641 733
Connection kit M5/R 1/8"		1 495 089*

* on request