

THIS DRAWING IS UNPUBLISHED. RELEASED FOR PUBLICATION
 © COPYRIGHT BY TYCO ELECTRONICS CORPORATION. ALL RIGHTS RESERVED.

LOC	DIST	REVISIONS					
CM	00	P	LTR	DESCRIPTION	DATE	DWN	APVD
		R		REVISED PER 0G3B-0007-04	13-JAN-04	KW	SR

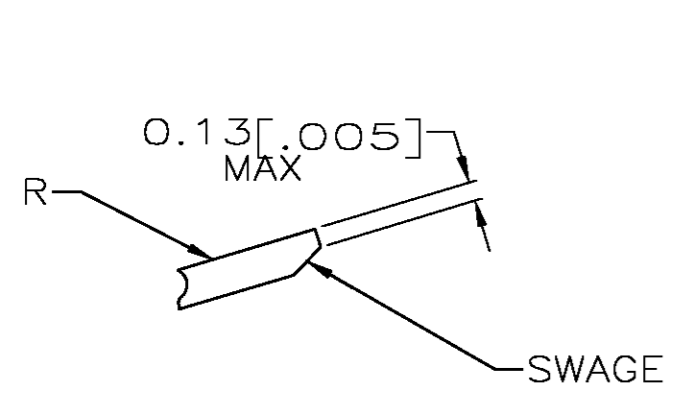

DETAIL D
SCALE 20:1

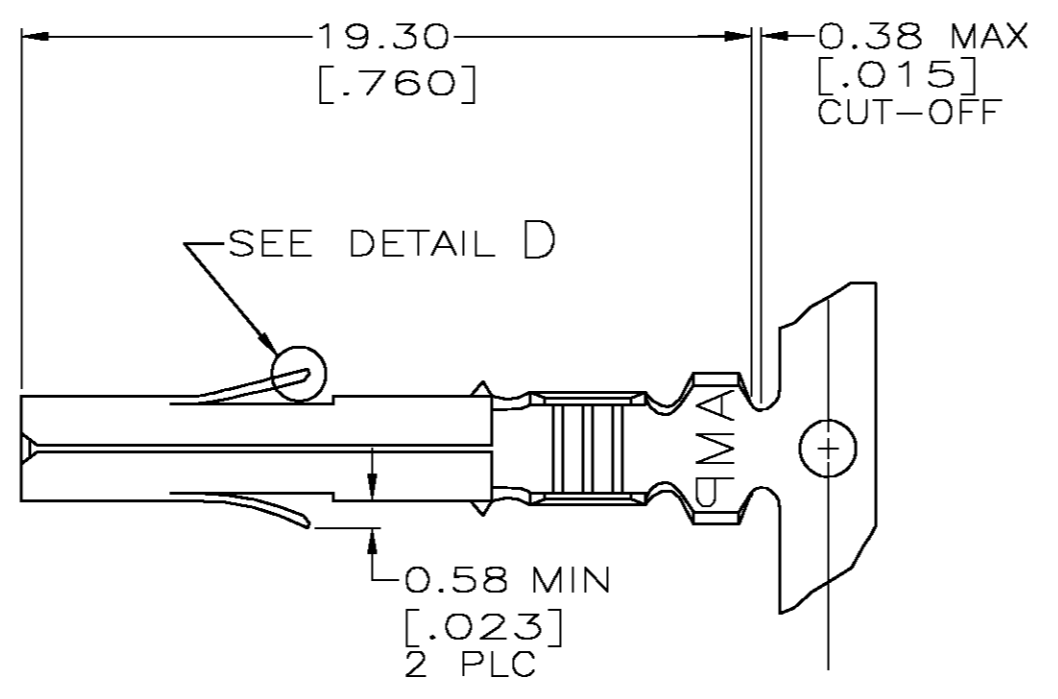

- 1 0.00076 [.000030] THICK GOLD OVER NICKEL ON INSIDE OF RECEPTACLE; REMAINDER OF CONTACT IS NICKEL PLATED.
- 2 0.00076 [.000030] THICK GOLD OVER NICKEL ON INSIDE OF RECEPTACLE AND WIRE BARREL; REMAINDER OF CONTACT IS NICKEL PLATED.
- 3 NOT MANUFACTURED UN USA.
- 4. DIMENSIONS IN BRACKETS ARE IN INCHES.

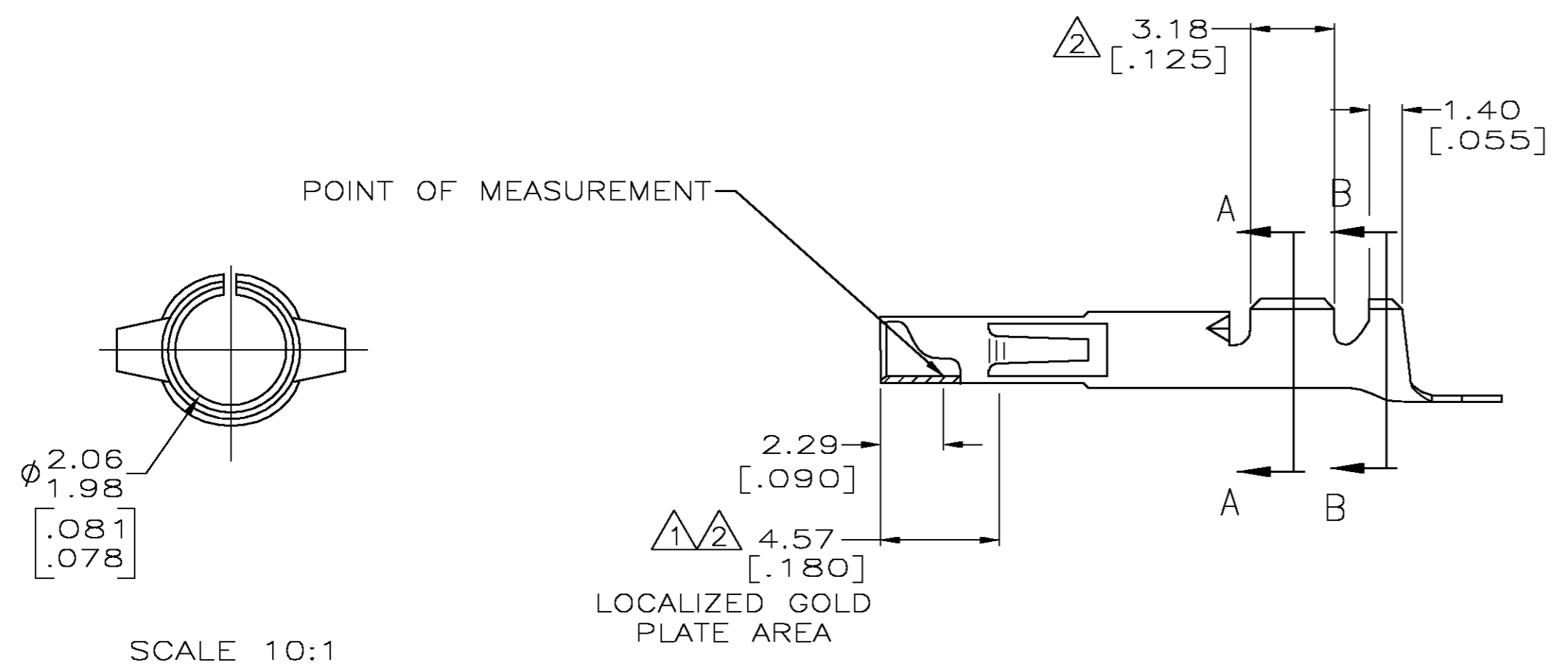

LOCALIZED GOLD PLATE AREA

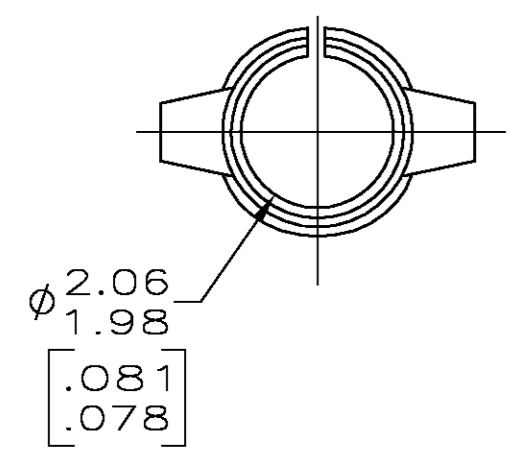

SCALE 10:1

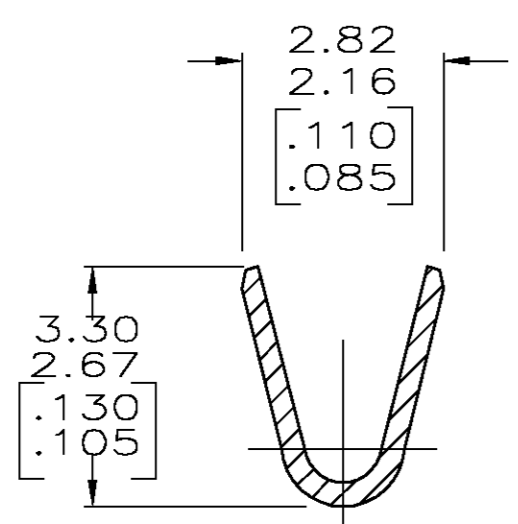

SECTION A-A
SCALE 10:1

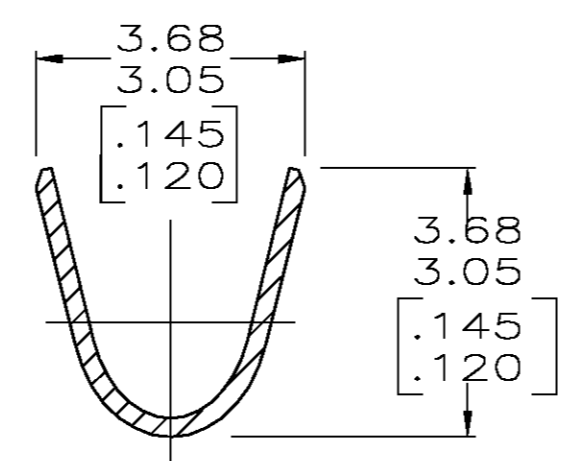

SECTION B-B
SCALE 10:1

MATERIAL	FINISH	PART NUMBER
0.25 [.010] BRASS	GOLD 1	350689-7
0.25 [.010] PH BRZ	GOLD 1 3	350689-6
0.25 [.010] PH BRZ	PRE-TIN	350689-3
0.25 [.010] BRASS	GOLD 2	350689-2
0.25 [.010] BRASS	PRE-TIN	350689-1

THIS DRAWING IS A CONTROLLED DOCUMENT.

DWN K. WHITAKER 13-JAN-04	Tyco Electronics Corporation Harrisburg, PA 17105-3608	SIZE	CAGE CODE	DRAWING NO	RESTRICTED TO	
CHK S. RIDGILL 13-JAN-04		A2	00779	C=350689	-	
APVD S. RIDGILL 13-JAN-04		SCALE	5:1	SHEET	1 OF 1	REV
PRODUCT SPEC		CUSTOMER DRAWING				

NAME: SOCKET,(LOOSE PIECE) UNIVERSAL MATE-N-LOK™

MATERIAL: 18-24 AWG
FINISH: 2.54 [.100] DIA MAX

TOLERANCES UNLESS OTHERWISE SPECIFIED:
 0 PLC ± -
 1 PLC ± -
 2 PLC ± 0.13 [.005]
 3 PLC ± -
 4 PLC ± -
 ANGLES ± 0°30'

