

PAGE #	PAGE TITLE	PAGE DESCRIPTION
1	TITLE	TITLE OF THE SCHEMATICS
2	TABLE OF CONTENTS	TABLE OF CONTENTS
3	BLOCK DIAGRAM	TOP LEVEL BLOCK DIAGRAM OF THE SCHEMATICS
4	POWER & RESET	COMPLETE POWER SUPPLY CIRCUITRY ON BOARD AND REST CKT
5	DSP POWER AND RS232 IF	DSP POWER PART AND RS232 INTERFACE
6	DSP MEMORY IF & JTAG	DDR-2, FLASH INTERFACE TO THE DSP & JTAG CIRCUITARY
7	DSP PHERIPHERALS & VIDO DAC	DSP PHERIPHERALS & VIDO DAC CIRCUITARY
8	DDR-2 & FLASH	DDR-2 & FLASH DEVICES FOR DSP
9	VIDEO DIGITAL DECODER	VIDEO DIGITAL DECODER CIRCUITARY
10	AUDIO	AUDIO INTERFACE CIRCUITARY
11	ETHERNET	ETHERNET MII INTERFACE
12	EXPANSION CONNECTORS	EXPANSION CONNECTORS FOR PROVIDING EXTERNAL INTERFACE

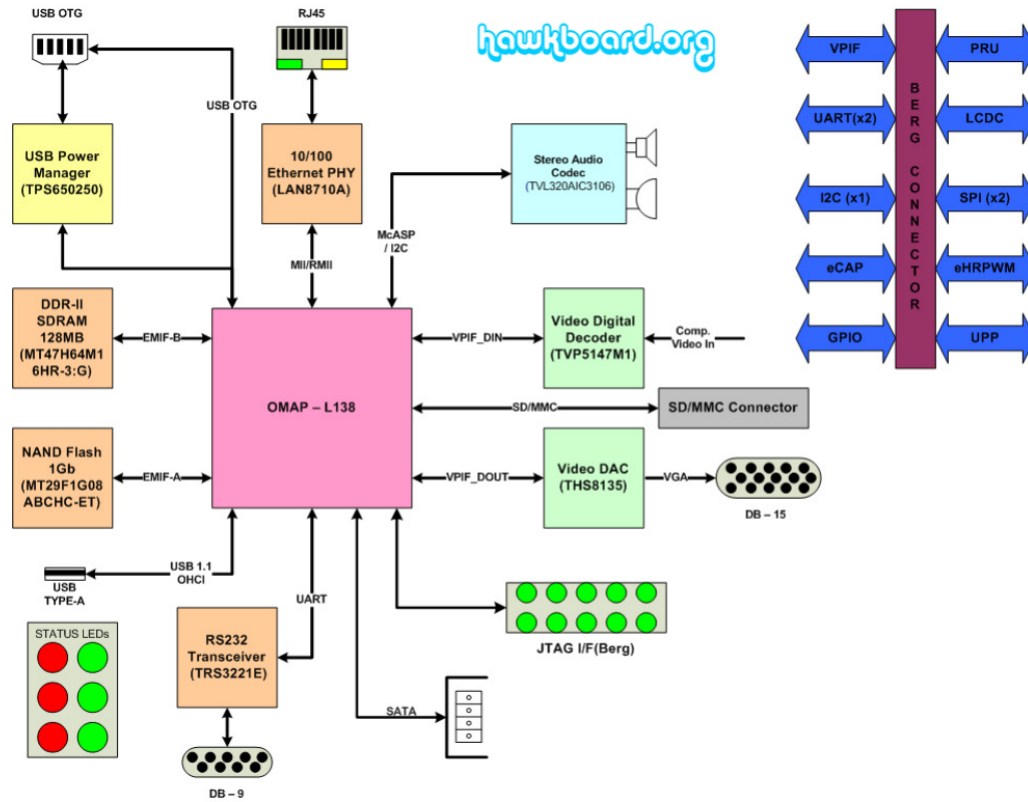

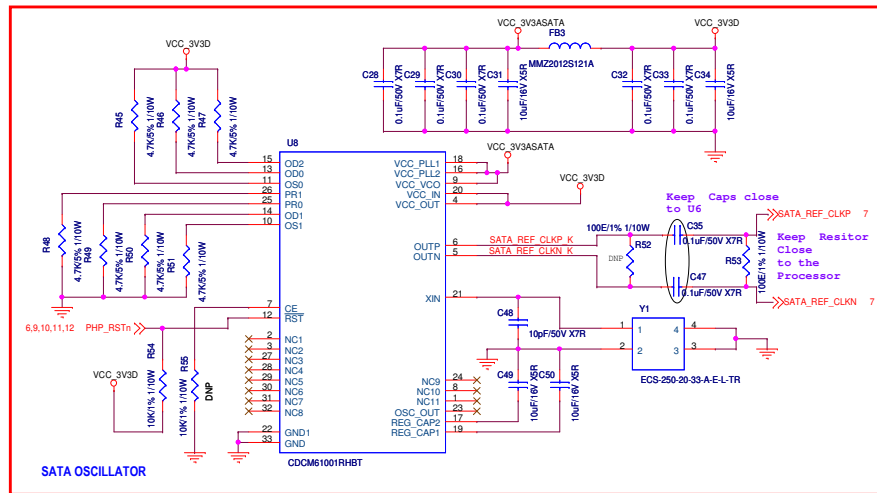

NOTE - 001 ALL DECAPS SHOULD BE PLACE WITHIN 1cm FROM EACH PIN

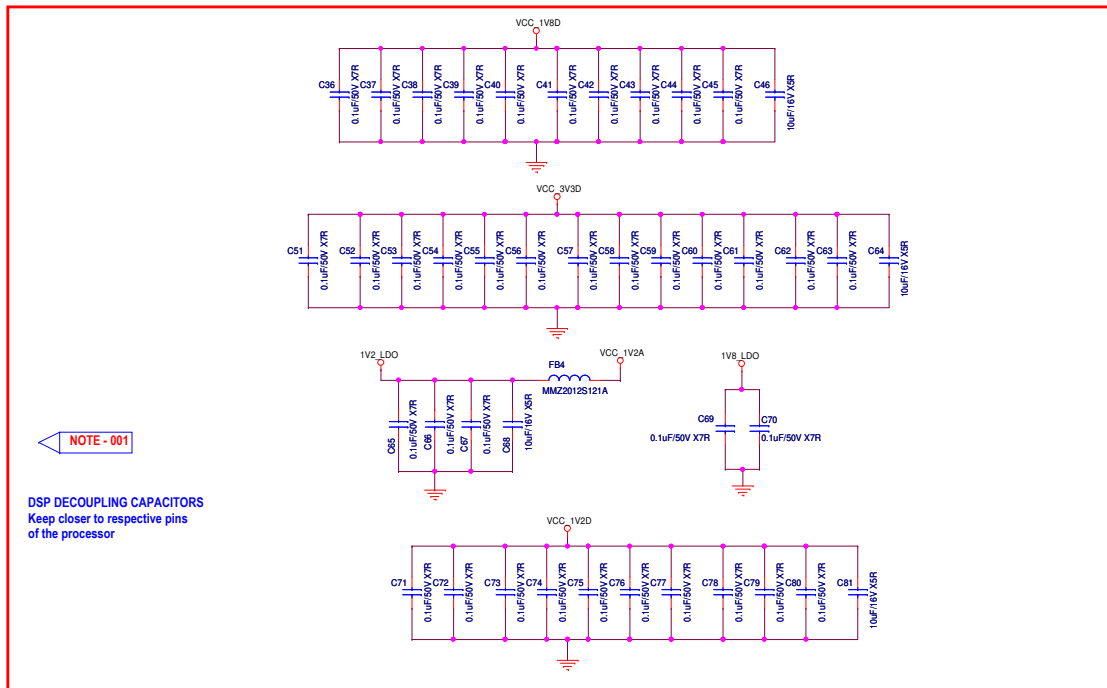
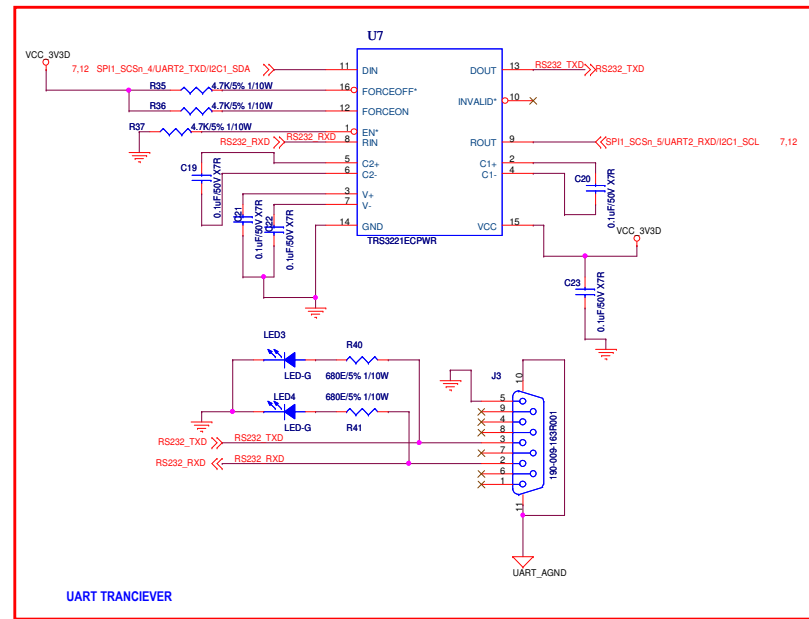
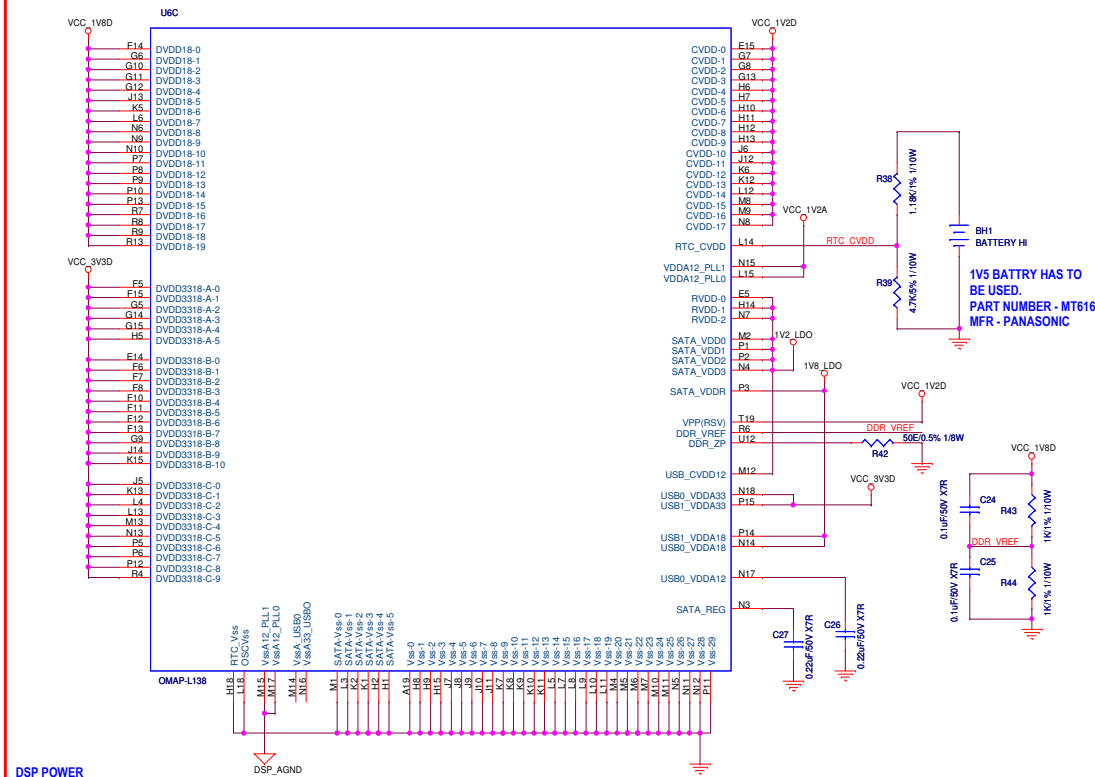
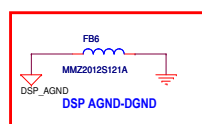
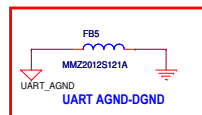

www.innovatesolutions.net

Title of Schematics : **hawkboard.org**

Title of Page : DSP POWER & RS232 IF

Page Size : C	Document Number :	Ver / Rev : 22
Date : Friday, December 11, 2009	<Document Number>	Page Number : 5 of 12

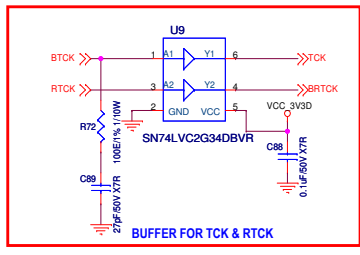
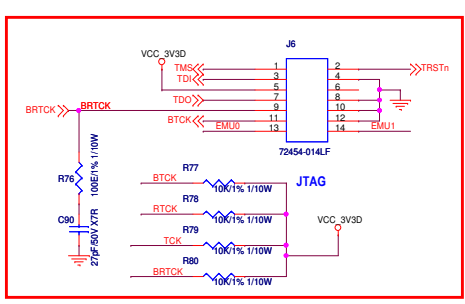
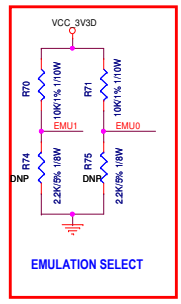
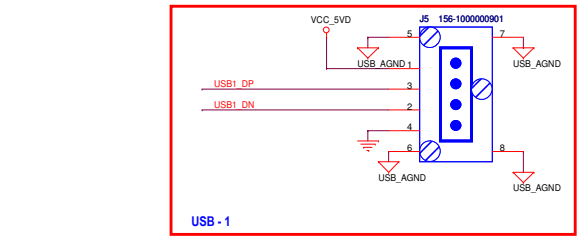
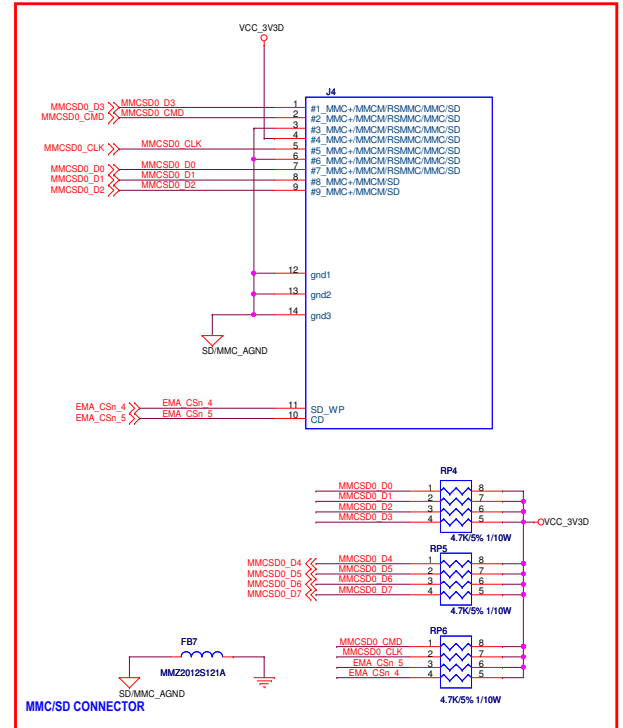
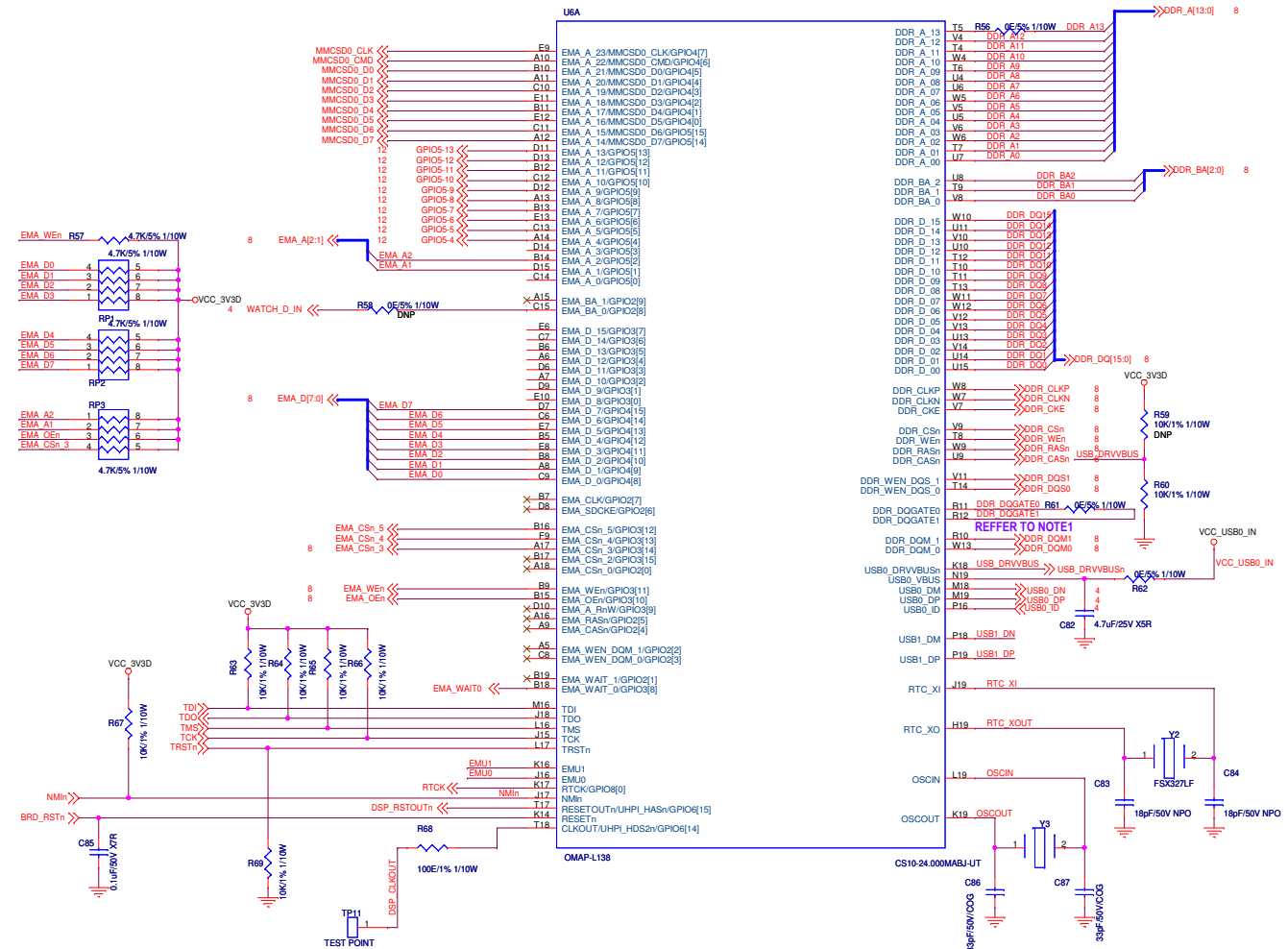

NOTE 1
 LAYOUT NOTE: ROUTE THIS PAIR OF SIGNALS PHYSICALLY CLOSE TO THE DATA BUS. KEEP BOTH SIGNALS CLOSE TO EACH OTHER. THERE IS NO IMPEDANCE REQUIREMENT FOR THESE SIGNALS.

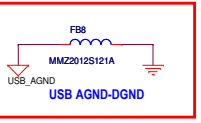
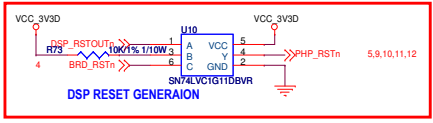

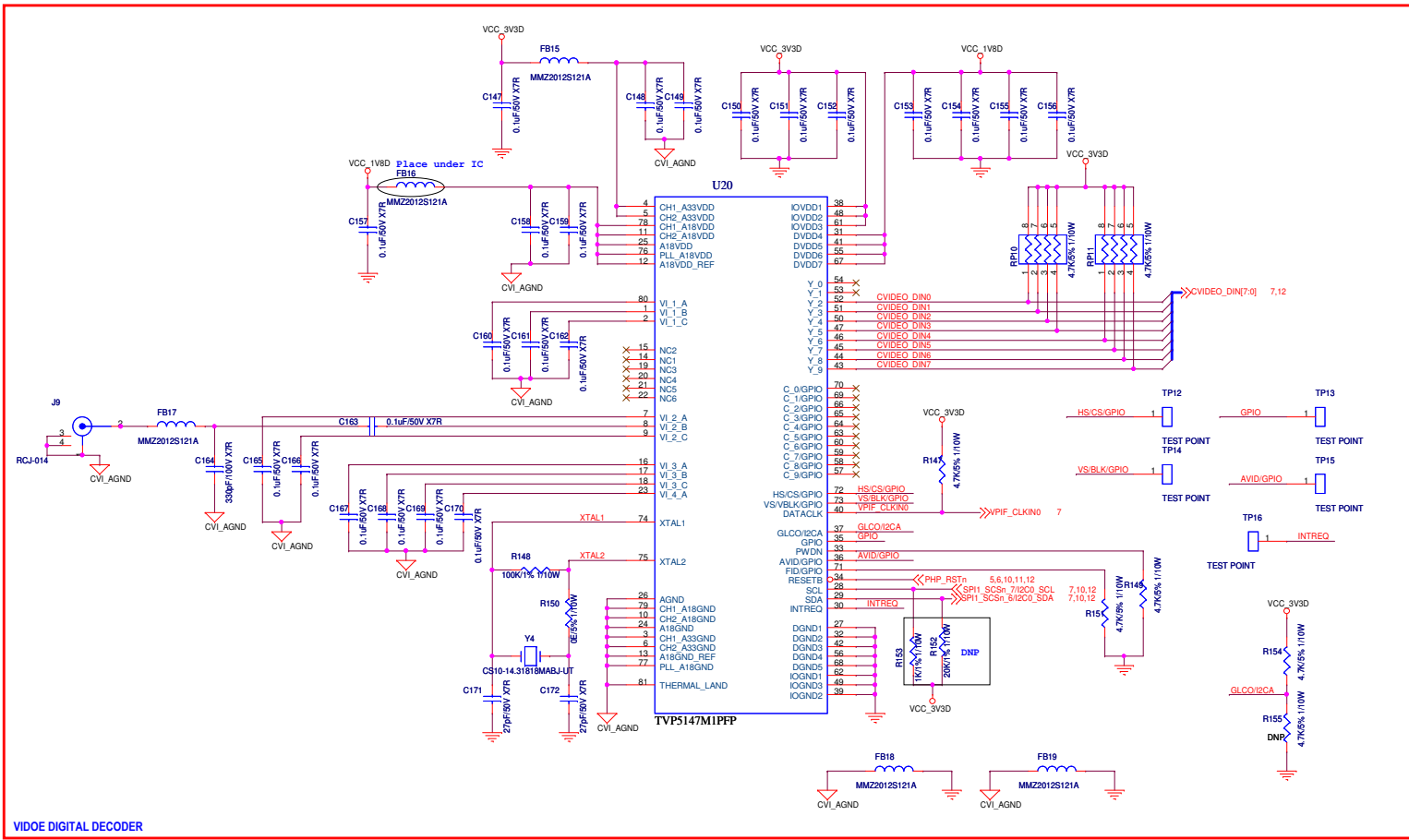

VIDEO DIGITAL DECODER

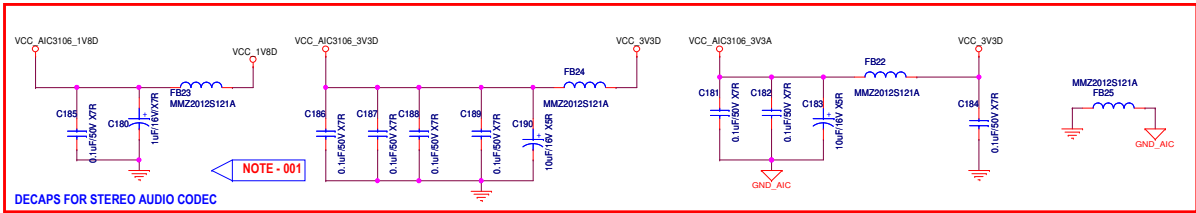
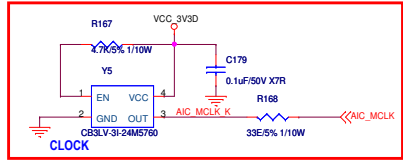
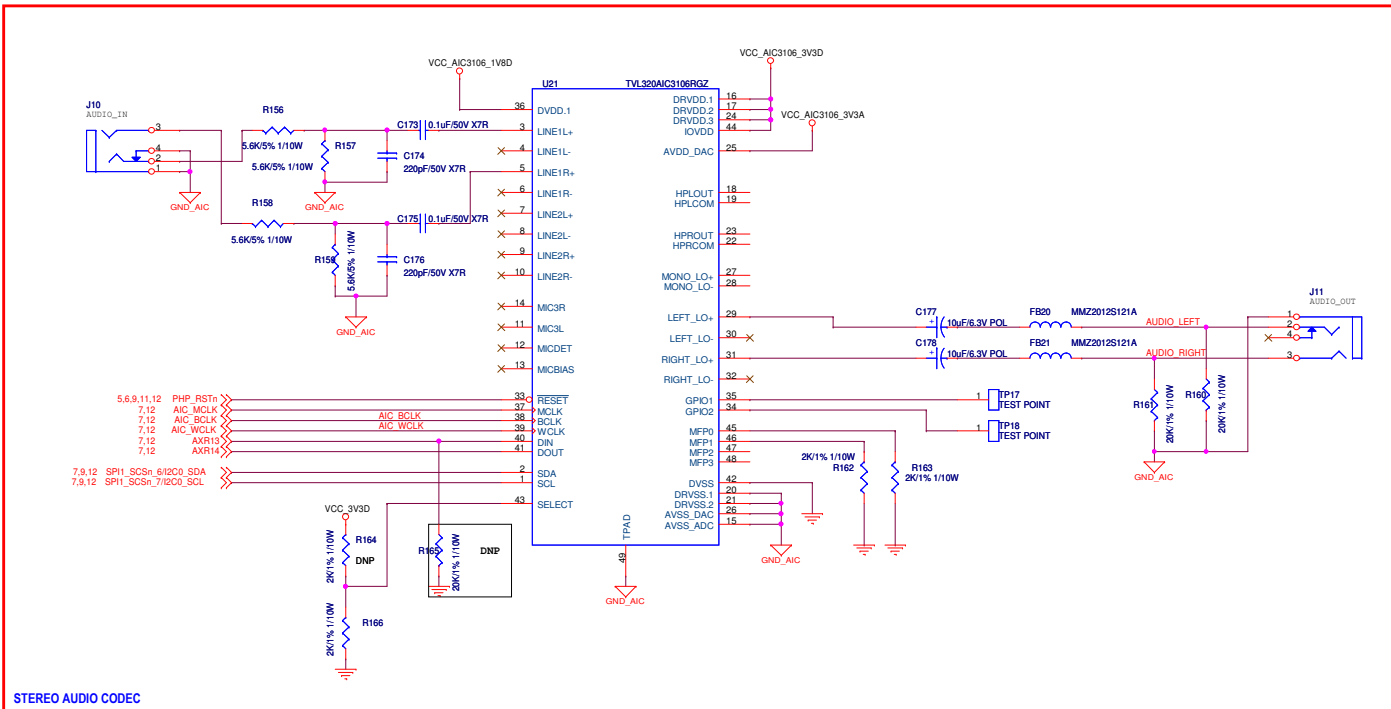

NOTE - 001 ALL DECAPS SHOULD BE PLACE WITHIN 1cm FROM EACH PIN

