

Ceramic Disc DC Capacitors

Class 2, Low Loss 500 V, 1 kV, 2 kV and 3 kV

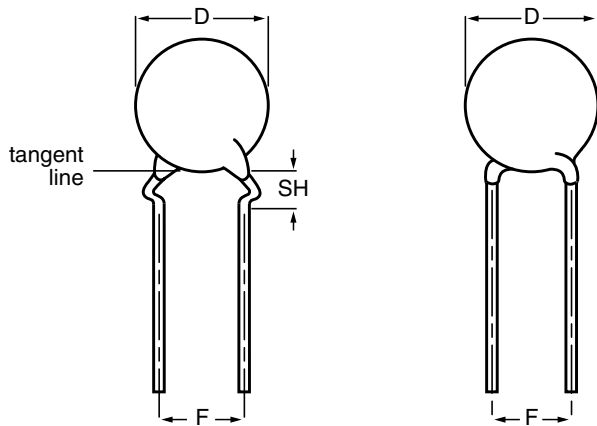

Capacitors with 5 mm (0.20"), 7.5 mm (0.30") and 10 mm (0.40") lead spacing

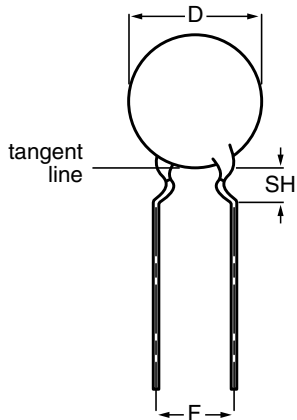

Capacitors with 5 mm (0.20") and 7.5 mm (0.30") lead spacing

MARKING

Marking indicates capacitance value and tolerance in accordance with "EIA 198" and voltage marks

EXAMPLES OF MARKING CODE

Disc size ($D_{max.}$) \leq 6.5 mm:	Disc size ($D_{max.}$) \geq 7.5 mm:
	BC
RP = low loss with T.C. Y5P	RP
101 K	102 K
2 kV	3 kV

FEATURES

- High reliability
- Low losses
- High capacitance in small size
- Kinked (preferred) or straight leads
- Compliant to RoHS directive 2002/95/EC



RoHS
COMPLIANT

APPLICATIONS

In electronic circuits where low losses and high capacitance per volume are essential, for example:

- SMPS
- HF ballast
- Snubber and high voltage circuits

DESIGN

The capacitors consist of a ceramic disc both sides of which are silver-plated. Connection leads are made of tinned copper having a diameter of 0.6 mm or 0.8 mm.

The capacitors may be supplied with kinked or straight leads with a lead spacing of 5 mm (0.200"), 7.5 mm (0.300") or 10 mm (0.400") and a lead length from 4 mm to 30 mm. The standard tolerance on capacitance is $\pm 10\%$. Encapsulation is made of gold coloured epoxy-resin, flammable resistant in accordance with "UL94V-0".

CAPACITANCE RANGE

100 pF to 4700 pF

RATED DC VOLTAGE

500 V; 1 kV; 2 kV; 3 kV

DIELECTRIC STRENGTH

200 % of rated voltage

INSULATION RESISTANCE AT 500 V (DC)

$\geq 10\,000\text{ M}\Omega$

TOLERANCE ON CAPACITANCE

$\pm 10\%$, other tolerances available on request

DISSIPATION FACTOR

0.5 % max.

TEMPERATURE COEFFICIENT

Y5P

OPERATING TEMPERATURE RANGE

- 30 °C to + 125 °C

SECTIONAL SPECIFICATIONS

Class 2 IEC 60384-9, EIA 198

CLIMATIC CATEGORY

30/85/21

The capacitors meet the essential requirements of "IEC 60384-9 and EIA 198". Unless stated otherwise all electrical values apply at an ambient temperature of $25 \pm 3\text{ }^\circ\text{C}$, at normal atmospheric conditions



ORDERING INFORMATION								
C (pF)	TOL. (%)	D _{max.} (mm)	LEAD SPACING F (mm)	SH ⁽²⁾ (mm)	CLEAR TEXT CODE			
					13 th DIGIT: T = REEL; U = AMMO; 3 = BULK 16 th DIGIT: R = RoHS COMPLIANT			
500 V								
100	± 10	5.0	5.0	4.0	F101K25Y5PL6.J5.			
120					F121K25Y5PL6.J5.			
150					F151K25Y5PL6.J5.			
180					F181K25Y5PL6.J5.			
220					F221K25Y5PL6.J5.			
270					F271K25Y5PL6.J5.			
330					F331K25Y5PL6.J5.			
390					F391K25Y5PL6.J5.			
470					F471K25Y5PL6.J5.			
560					F561K25Y5PL6.J5.			
680		6.5	5.0	4.0	F681K25Y5PL6.J5.			
820					F821K25Y5PL6.J5.			
1000					F102K29Y5PL6.J5.			
1200					F122K33Y5PL6.J5.			
1500					F152K33Y5PL6.J5.			
1800					F182K39Y5PL6.J5.			
2200					F222K39Y5PL6.J5.			
2700					F272K43Y5PL6.J5.			
3300					7.5	7.5	4.0	F332K47Y5PL6J7.
3900								F392K53Y5PL6J7.
1 kV								
100	± 10	6.5	5.0	4.0	F101K25Y5PN6.J5.			
120					F121K25Y5PN6.J5.			
150					F151K25Y5PN6.J5.			
180					F181K25Y5PN6.J5.			
220					F221K25Y5PN6.J5.			
270					F271K25Y5PN6.J5.			
330					F331K25Y5PN6.J5.			
390					F391K25Y5PN6.J5.			
470					F471K25Y5PN6.J5.			
560					F561K29Y5PN6.J5.			
680		7.5	5.0	4.0	F681K29Y5PN6.J5.			
820					F821K33Y5PN6.J5.			
1000					F102K33Y5PN6.J5.			
1200					F122K39Y5PN6.J5.			
1500					F152K39Y5PN6.J5.			
1800					F182K39Y5PN6.J5.			
2200					F222K43Y5PN6.J5.			
2700					13.5	7.5	4.8	F272K53Y5PN6J7.
3300								F332K59Y5PN6J7.
3900					15.0	7.5	4.8	F392K59Y5PN6J7



Ceramic Disc DC Capacitors
Class 2, Low Loss 500 V, 1 kV, 2 kV and 3 kV

Vishay BCcomponents

ORDERING INFORMATION					
C (pF)	TOL. (%)	D _{max.} (mm)	LEAD SPACING F (mm)	SH ⁽²⁾ (mm)	CLEAR TEXT CODE
					13 th DIGIT: T = REEL; U = AMMO; 3 = BULK 16 th DIGIT: R = RoHS COMPLIANT
2 kV					
100	± 10	6.5	5.0	4.0	F101K25Y5PP6.K5.
120					F121K25Y5PP6.K5.
150					F151K25Y5PP6.K5.
180					F181K25Y5PP6.K5.
220					F221K25Y5PP6.K5.
270					F271K29Y5PP6.K5.
330		7.5	5.0	4.0	F331K29Y5PP6.K5.
390					F391K29Y5PP6.K5.
470					F471K29Y5PP6.K5.
560					F561K33Y5PP6.K5.
680		8.5	5.0	4.0	F681K33Y5PP6.K5.
820					F821K43Y5PP6.K5.
1000		11.0	5.0	4.0	F102K43Y5PP6.K5.
1200					F122K43Y5PP6.K5.
1500		12.0	7.5	4.8	F152K47Y5PP63K7.
1800					F182K59Y5PP63K7.
2200		15.0	7.5	4.8	F222K59Y5PP63K7.
2700					F272K69Y5PP63K7.
3300		17.5	7.5	4.8	F332K69Y5PP63K7.
3900					F392K75Y5PP83K0.
4700	19.0	10.0	4.8	F472K75Y5PP83K0.	
3 kV					
100	± 10	8.5	7.5	4.0	F101K33Y5PR6.K7.
120					F121K33Y5PR6.K7.
150					F151K33Y5PR6.K7.
180					F181K33Y5PR6.K7.
220					F221K33Y5PR6.K7.
270					F271K33Y5PR6.K7.
330		11.0	7.5	4.0	F331K33Y5PR6.K7.
390					F391K33Y5PR6.K7.
470					F471K33Y5PR6.K7.
560					F561K33Y5PR6.K7.
680		11.0	7.5	4.0	F681K43Y5PR6.K7.
820					F821K43Y5PR6.K7.
1000		13.5	7.5	4.8	F102K43Y5PR63K7.
1200					F122K53Y5PR63K7.
1500		15.0	7.5	4.8	F152K59Y5PR63K7.
1800					F182K59Y5PR63K7.
2200		19.0	10.0	4.8	F222K59Y5PR63K7.
2700					F272K75Y5PR83K0.

Notes

- (1) Maximum thickness: 500 V = 3.5 mm; 1 kV = 4.5 mm; 2 kV = 5.0 mm; 3 kV = 6.0 mm.
- (2) SH = seated height.
- (3) Lead style codes refer to kinked leads. Other styles available on request.

PACKAGING					
PACKAGING TYPE	SIZE CODE	LEAD SPACE (mm)	VOLTAGE (VDC)	SPQ	BOX DIMENSIONS L x W x H (mm)
Bulk (long lead $L \geq 25.4$ mm)	20 to 47	all	all	1000	245 x 120 x 65
				1000	
	53 to 75			500	
	84 to 96			250	
Tape and reel	≤ 47	≤ 6.4	$500 \leq WV \leq 2000$	2500	370 x 370 x 60
			3000	2000	
	≥ 53	≥ 7.5	all	1000	
			all	500	
Ammopack	≤ 47	≤ 6.4	$500 \leq WV < 2000$	2000	335 x 240 x 50
			2000 and 3000	2000	335 x 290 x 50
			all	1500	360 x 330 x 55
	≥ 53	≥ 7.5	all	1500	360 x 330 x 55
		≥ 53	≥ 7.5	all	500

Note

The capacitors are supplied in bulk packaging (cardboard boxes), in tape on reel or in ammpack.

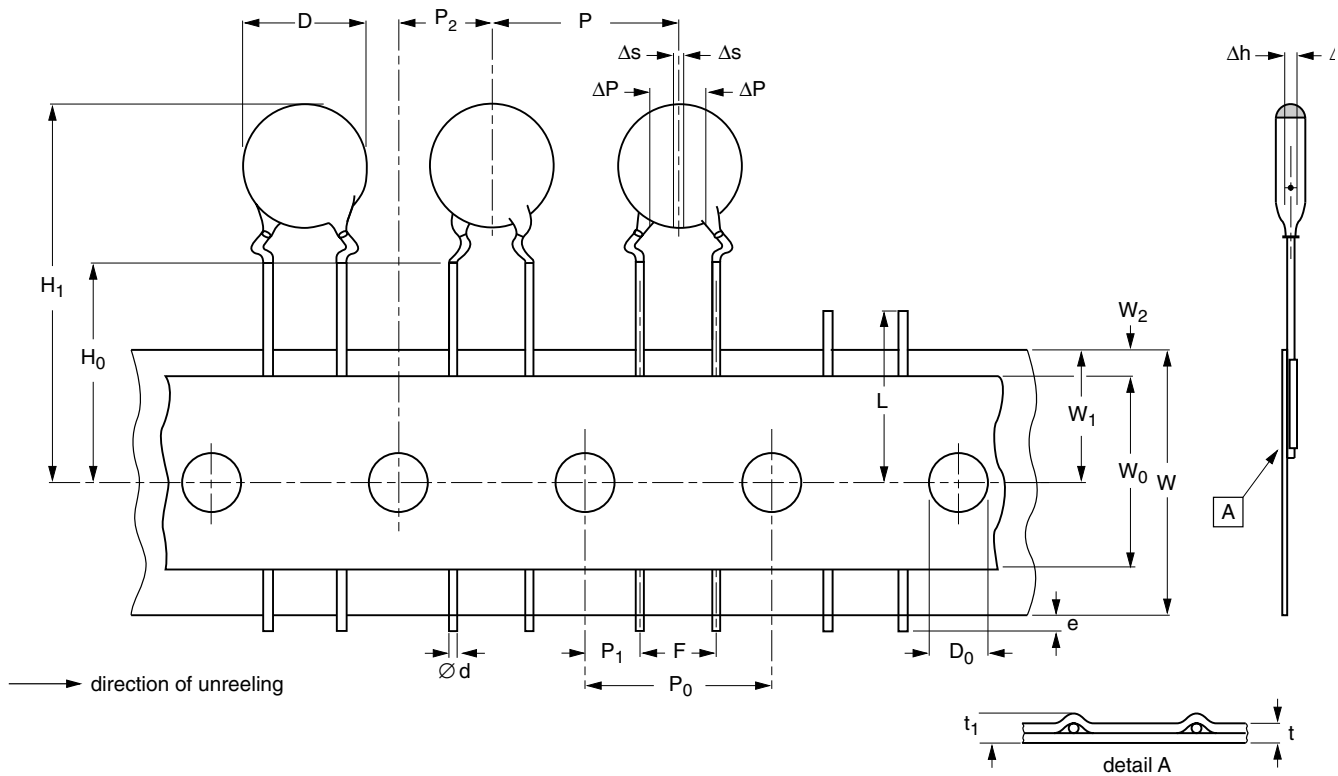

DIMENSIONS OF TAPE			
SYMBOL	PARAMETER	DIMENSIONS (mm)	
		FEED-HOLE PITCH $P_0 = 12.7$	FEED-HOLE PITCH $P_0 = 15.0$
D	body diameter	11.0 max.	14.0 max.
d	lead diameter	0.6 ± 0.05	0.6 ± 0.05
P	pitch between capacitors	12.7 ± 1.0	15.0 ± 1.0
P0	feed-hole pitch	12.7 ± 0.3 ; ⁽¹⁾	15.0 ± 0.3 ; ⁽¹⁾
ΔP	plane deviation	1.0 max.	1.0 max.
P1	feed-hole centre to lead centre	3.85 ± 0.7 ; ⁽²⁾	3.75 ± 0.7 ; ⁽²⁾
P2	feed-hole centre to component centre	6.35 ± 1.3 ; ⁽²⁾	7.5 ± 1.5 ; ⁽²⁾
F	lead spacing	$5.0 + 0.6/- 0.4$	$7.5 + 0.6/- 0.4$
Δh	component alignment	0 ± 1.0	0 ± 1.0
W	tape width	$18.0 + 1.0/- 0.5$	$18.0 + 1.0/- 0.5$
W0	hold-down tape width	5.0 min.	5.0 min.
W1	hole position	$9.0 + 0.75/- 0.5$	$9.0 + 0.75/- 0.5$
W2	hold-down tape margin	3.0 max.	3.0 max.
H0	height to seating plane	16.0 ± 0.5	16.0 ± 0.5
H1	maximum component height	32.0	40.0
e	lead end protrusion	1.0 max.	1.0 max.
L	maximum length of snapped lead	11.0	11.0
D0	feed-hole diameter	4.0 ± 0.2	4.0 ± 0.2
t	total tape thickness	0.9 max.	0.9 max.
t1	maximum thickness of tape and wires	1.5 max.	1.5 max.

Notes
⁽¹⁾ Cumulative pitch error: $\pm \leq 1$ mm/20 pitches.

⁽²⁾ Obliquity maximum 3°.

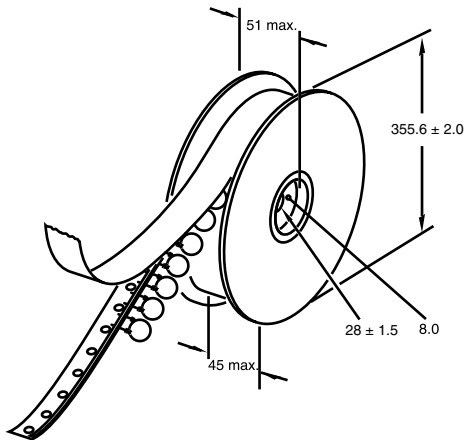
REEL AND TAPE DATA in millimeters

Reel with capacitors on tape

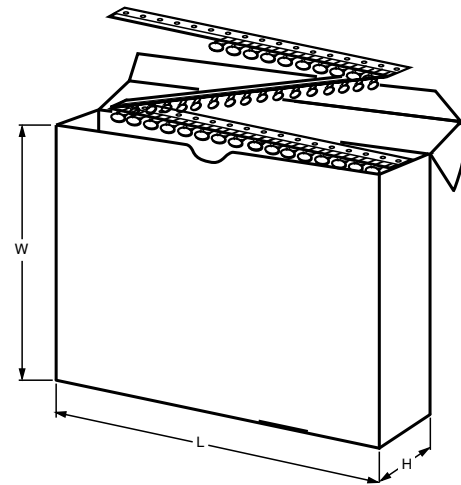

Ammpack with capacitors on tape

DIMENSIONS OF AMMOPACK			
PARAMETER	DISC SIZE ($D_{max.}$)		UNIT
	6.5 mm to 11.0 mm	12.0 mm to 13.5 mm	
Taping pitch	12.7	15.0	mm
L	335	360	mm
W	290	330	mm
H	50	55	mm



Disclaimer

All product specifications and data are subject to change without notice.

Vishay Intertechnology, Inc., its affiliates, agents, and employees, and all persons acting on its or their behalf (collectively, "Vishay"), disclaim any and all liability for any errors, inaccuracies or incompleteness contained herein or in any other disclosure relating to any product.

Vishay disclaims any and all liability arising out of the use or application of any product described herein or of any information provided herein to the maximum extent permitted by law. The product specifications do not expand or otherwise modify Vishay's terms and conditions of purchase, including but not limited to the warranty expressed therein, which apply to these products.

No license, express or implied, by estoppel or otherwise, to any intellectual property rights is granted by this document or by any conduct of Vishay.

The products shown herein are not designed for use in medical, life-saving, or life-sustaining applications unless otherwise expressly indicated. Customers using or selling Vishay products not expressly indicated for use in such applications do so entirely at their own risk and agree to fully indemnify Vishay for any damages arising or resulting from such use or sale. Please contact authorized Vishay personnel to obtain written terms and conditions regarding products designed for such applications.

Product names and markings noted herein may be trademarks of their respective owners.