

Features

- Replacement for R-78Axx-0.5SMD series
- RoHS 6/6 Conform (100% Lead Free)
- Efficiency up to 97%, Non isolated, no need for heatsinks
- High Reflow Temperature SMD Package
- Adjustable Output Voltage
- Wide input range.(4.75V ~ 32V)
- Short circuit protection, Thermal shutdown
- Remote On/Off Control
- UL94V-0 Package Material
- Very Low Shutdown Current
- See Ininline Application Notes for use as an inverter (alternative to LM79xx Linear)

Description

The R-78Axx-0.5SMD series are manufactured without lead and meet the requirements for RoHS 6/6 as well as the increased reflow soldering temperatures associated with vapour phase soldering, making these high efficiency switching regulators ideally suited to modern pick-and-place mass production. The efficiency of up to 97% means that very little energy is wasted as heat. The additional features of remote on/off control and adjustable output voltages will find many uses in the battery-powered, industrial, medical and automotive markets.

Selection Guide

| Part Number SMD | Input Range (1) (V) | Output Voltage (V) | Adjust Range (V) | Output Current (A) | Efficiency | |
|------------------|---------------------|--------------------|------------------|--------------------|--------------|--------------|
| | | | | | Min. Vin (%) | Max. Vin (%) |
| R-78AA1.5-0.5SMD | 4.75 – 30 | 1.5 | fixed | 0.5 | 73 | 63 |
| R-78AA1.8-0.5SMD | 4.75 – 32 | 1.8 | 1.5~3.0 | 0.5 | 82 | 71 |
| R-78AA2.5-0.5SMD | 4.75 – 32 | 2.5 | 1.5~3.0 | 0.5 | 87 | 77 |
| R-78AA3.3-0.5SMD | 4.75 – 32 | 3.3 | 3.0~5.5 | 0.5 | 91 | 81 |
| R-78AA5.0-0.5SMD | 6.5 – 32 | 5.0 | 3.0~8.0 | 0.5 | 94 | 86 |
| R-78AA6.5-0.5SMD | 8.0 – 32 | 6.5 | 3.3~11.0 | 0.5 | 95 | 88 |
| R-78AA9.0-0.5SMD | 11 – 32 | 9.0 | 4.5~12.6 | 0.5 | 96 | 92 |
| R-78AA12-0.5SMD | 15 – 32 | 12 | 4.5~12.6 | 0.5 | 97 | 94 |
| R-78AA15-0.5SMD | 18 – 32 | 15 | fixed | 0.5 | 97 | 95 |

Note 1: 1.5V Output can be unstable with Vin>30VDC

* add suffix -R for tape&reel packing e.g. R-78AA5.0-0.5-R. For more details see Application Notes.

Standard Application Circuit

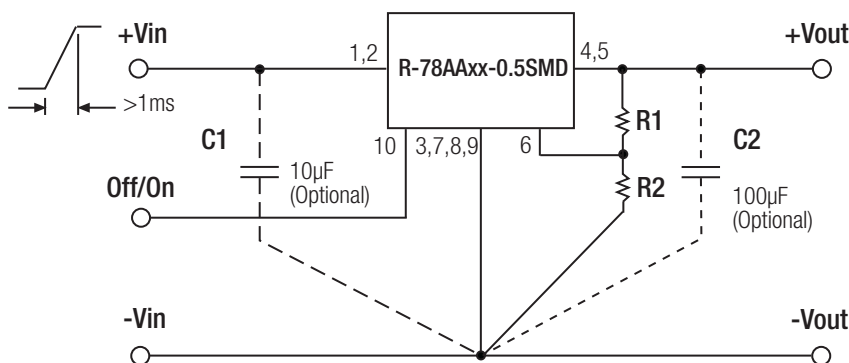

To protect the converter from high inrush currents, use soft start Vin and C1=10µF
Output capacitor C2 recommended if load is very dynamic

INNOLINE DC/DC-Converter

RECOM

0.5 AMP SMD Single Output

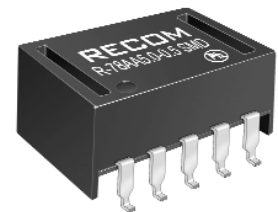

EN-60950-1 Certified

R-78AA-0.5

Derating-Graph (Ambient Temperature)

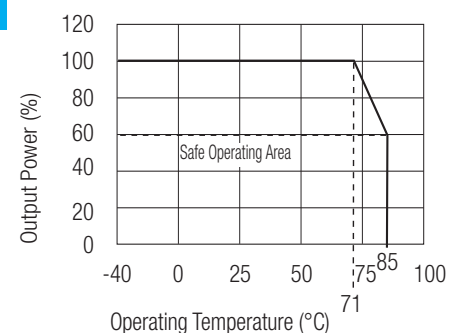

Specifications (typical at 25°C, 10% minimum load, unless otherwise specified)

| Characteristics | Conditions | Min. | Typ. | Max. |
|---|--|---------------------|-------------------------------------|-----------------------------------|
| Input Voltage Range | See Table | 4.75V | 32V | 34V abs. max. |
| Output Voltage Range | See Table | 1.5V | | 15V |
| Output Current (see Note) | All Series | 0mA* | | 500mA |
| Output Current Limit | All Series | | | 2000mA |
| Short Circuit Input Current | V _{in} = 24V | | 60mA | 100mA |
| Internal Power Dissipation | | | | 0.4W |
| Short Circuit Protection | | | Continuous, automatic recovery | |
| Output Voltage Accuracy | 100% Load | | ±2% | ±3% |
| Adjustable Voltage Range | See Table 1 | | | ±50% |
| Line Voltage Regulation (V _{in} = min. to max. at full load) | 1.5V to 6.5V | | 0.2% | 0.4% |
| | 9V to 15V | | 0.1% | 0.2% |
| Load Regulation (10 to 100% full load) | 1.5V to 6.5V | | 0.7% | 1.0% |
| | 9V to 15V | | 0.25% | 0.4% |
| Dynamic Load Stability with 100µF Output capacitor | 100% <-> 50% load | | ±75V | ±100mV |
| | 100% <-> 10% load | | ±100mV | |
| Ripple & Noise (without Output Capacitor) | 1.5V to 6.5V | | 20mVp-p | 30mVp-p |
| | 9V to 15.5V | | 30mVp-p | 40mVp-p |
| Temperature Coefficient | -40°C ~ +85°C ambient | | | 0.015%/°C |
| Max capacitance Load | | | | 220µF |
| Switching Frequency | | 280kHz | 330kHz | 380kHz |
| Quiescent Current | V _{in} = min. to max. at 0% load | | 5mA | 7mA |
| ON/OFF Remote Control Pin Drive Current | | | I _r =1.8µA typ | |
| Converter Input Current (valid for V _r < 1.6V) | | | 20µA | 30µA |
| Remote On/Off Threshold Voltage (V _r rising) | | 2.4V | 2.6V | 2.8V |
| Remote On/Off Voltage Hysteresis | | | 250mV | |
| Operating Temperature Range (with derating) | | -40°C | | +85°C |
| Switch On/Off Time | (using Remote On/Off Control) | | | 50ms |
| Operating Case Temperature | | | | +100°C |
| Storage Temperature Range | | -55°C | | +125°C |
| Case Thermal Impedance | | | | 70°C / W |
| Thermal Shutdown | Internal IC junction | | | +160°C |
| EMC | Conducted Emissions | EN55022 | | Class B |
| | Radiated Emissions | EN55022 | | Class B |
| | ESD | EN61000-4-2 | | Class A |
| | Radiated Immunity | EN61000-4-3 | | Class A |
| | Fast Transient | EN61000-4-4 | | Class A |
| | Conducted Immunity | EN61000-4-6 | | Class A |
| | Magnetic Field Immunity | EN61000-4-8 | | Class A |
| Safety Certification | | | | EN 60950-1 |
| Package Weight | | | 2.7g | |
| Packing Quantity | | | | 33pcs per Tube 250pcs per Reel |
| MTBF (+25°C) (+71°C) | } Detailed Information see Application Notes chapter "MTBF" | using MIL-HDBK 217F | 21098~29253 x 10 ³ hours | |
| | | | 4214-7365 x 10 ³ hours | |

*Note: Operation under no load will not damage these devices, however they may not meet all specifications. A minimum load of 6mA is recommended

Characteristics

Efficiency

Ripple

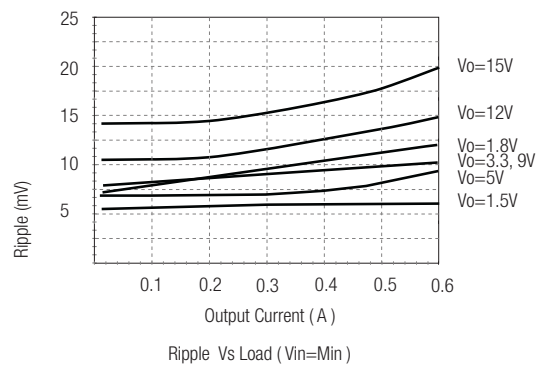
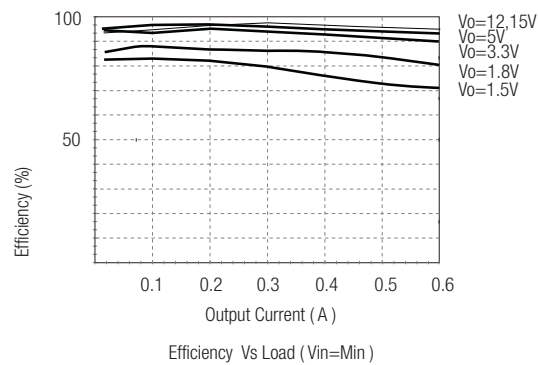
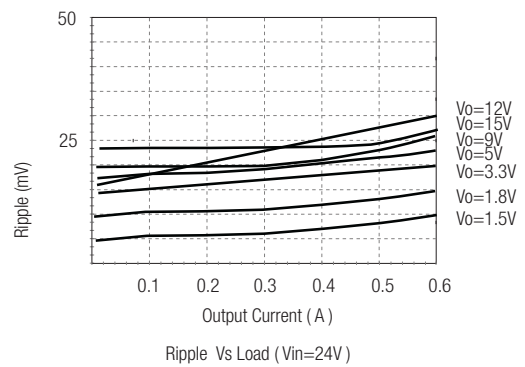
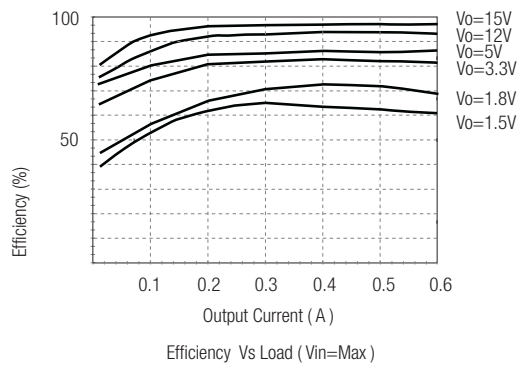
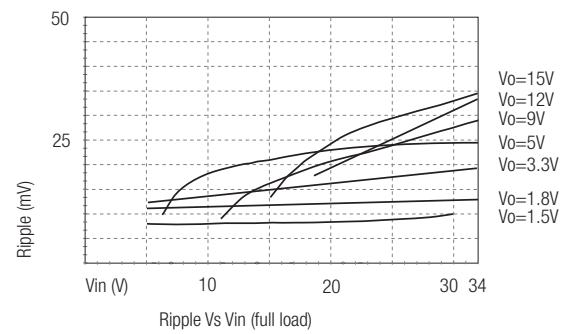
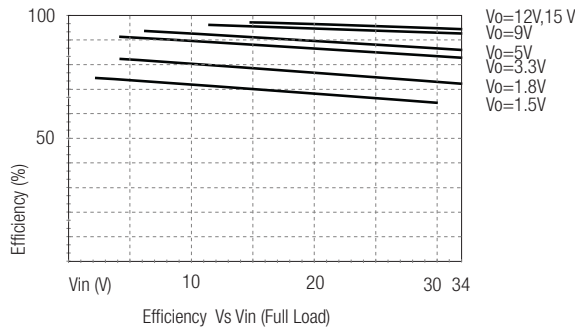

Application Examples

Flash Memory Program Voltage Switcher

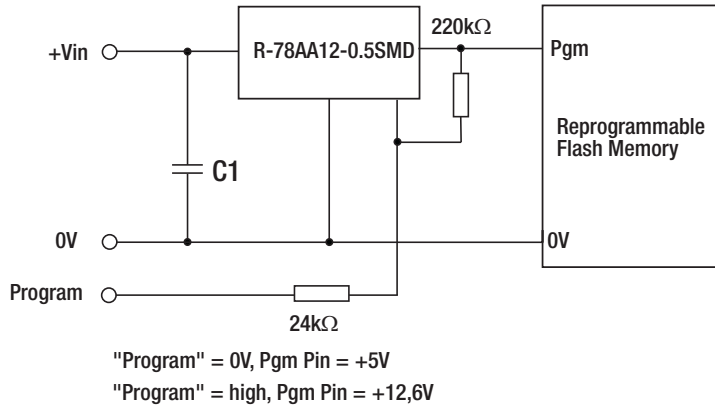

DC/DC Converter (1:1)

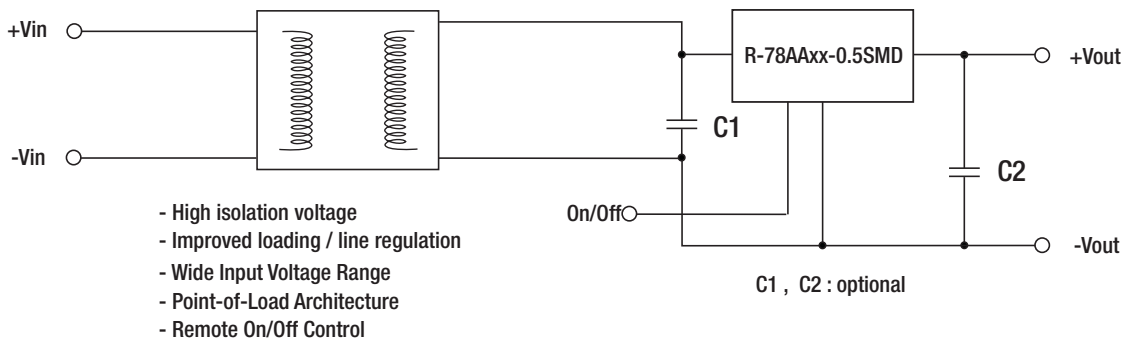

R-78AA-0.5

Optional Protection Circuit

Optional Protection 1:

Add a blocking diode to Vout if current can flow backwards into the output, as this can damage the converter when it is powered down.

The diode can either be fitted across the device if the source is low impedance or fitted in series with the output (recommended).

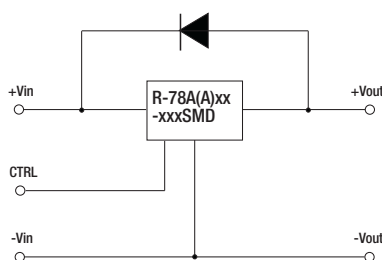

Optional Protection 2:

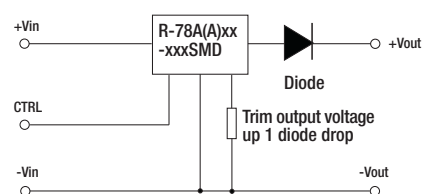

Table 1: Adjustment Resistor Values

| 0.5Adc | R-78AA1.8 -0.5SMD | | R-78AA2.5 -0.5SMD | | R-78AA3.3 -0.5SMD | | R-78AA5.0 -0.5SMD | | R-78AA6.5 -0.5SMD | | R-78AA9.0 -0.5SMD | | R-78AA12 -0.5SMD | |
|-------------|----------------------|----------------|----------------------|----------------|----------------------|----------------|----------------------|----------------|----------------------|---------------|----------------------|----|---------------------|----|
| Vout (nom.) | 1.8Vdc | | 2.5Vdc | | 3.3Vdc | | 5.0Vdc | | 6.5Vdc | | 9.0Vdc | | 12.0Vdc | |
| Vout (adj) | R1 | R2 | R1 | R2 | R1 | R2 | R1 | R2 | R1 | R2 | R1 | R2 | R1 | R2 |
| 1.5 (V) | 3K Ω | | 200 Ω | | | | | | | | | | | |
| 1.8 (V) | | | 12K Ω | | | | | | | | | | | |
| 2.5 (V) | | 11.8K Ω | | | | | | | | | | | | |
| 3.0 (V) | | 4.64K Ω | 44.2K Ω | 88.4K Ω | 17K Ω | | | | | | | | | |
| 3.3 (V) | | | | | | 27K Ω | 6.7K Ω | | | | | | | |
| 3.6 (V) | | | | | 60.4K Ω | 42K Ω | 14K Ω | | | | | | | |
| 3.9 (V) | | | | | 28K Ω | 58K Ω | 23K Ω | | | | | | | |
| 4.5 (V) | | | | | 11.3k Ω | 180K Ω | 49K Ω | 26K Ω | 17K Ω | | | | | |
| 4.9 (V) | | | | | 7.15k Ω | 850K Ω | 77k Ω | 36K Ω | 24K Ω | | | | | |
| 5.0 (V) | | | | | 6.34k Ω | | 86k Ω | 39K Ω | 26K Ω | | | | | |
| 5.1 (V) | | | | | 5.9k Ω | 231k Ω | 97K Ω | 42K Ω | 28K Ω | | | | | |
| 5.5 (V) | | | | | 3.9k Ω | 56.2k Ω | 160K Ω | 56K Ω | 36K Ω | | | | | |
| 6.5 (V) | | | | | | | 14k Ω | 112K Ω | 63K Ω | | | | | |
| 8.0 (V) | | | | | | | 2.32k Ω | 24.6K Ω | 400K Ω | 125K Ω | | | | |
| 9.0 (V) | | | | | | | | 10.7K Ω | 200K Ω | | | | | |
| 10 (V) | | | | | | | | 4.75K Ω | 54.9K Ω | 345K Ω | | | | |
| 11 (V) | | | | | | | | 1.65K Ω | 16.5K Ω | 740K Ω | | | | |
| 12 (V) | | | | | | | | | 3.6K Ω | | | | | |
| 12.6 (V) | | | | | | | | | 0 Ω | 180K Ω | | | | |

R-78AA-0.5

Package Style and Pinning (mm)

SMD 10Pin Package

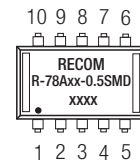
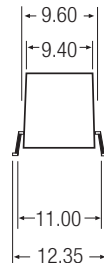
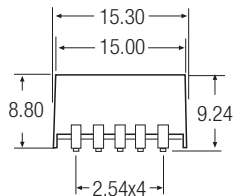

Recommended Footprint Details

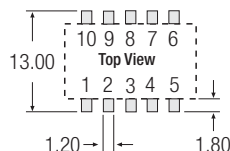
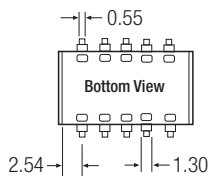

Pin Connections

| Pin # | Connection |
|---------|---------------|
| 1,2 | +Vin |
| 3,7,8,9 | GND |
| 4,5 | +Vout |
| 6 | V adj |
| 10 | Remote On/Off |

xx.x $\pm 0.5\text{mm}$
xx.xx $\pm 0.25\text{mm}$