

Short Barrel 3-Wire Prox Sensors Meet IP67

- Thick nickel-plated brass barrel has wrench flats for easy installation
- Solid potted internal circuitry withstands shocks and water washdown to IP67
- High visibility indicator
- Miniature and standard sizes



Ordering Information

WHEN ORDERING, PLEASE NOTE: Omron has added the suffix “-N” to standard size E2E part numbers for ordering purposes only; the suffix “-N” will not appear on the product.

■ PREWIRED MINIATURE SENSORS

Type	Size	Sensing distance	Output configuration	Part number	
				NO	NC
	4 mm dia.	0.8 mm	NPN	E2E-CR8C1	E2E-CR8C2
			PNP	E2E-CR8B1	E2E-CR8B2
	M5	1 mm	NPN	E2E-X1C1	E2E-X1C2
			PNP	E2E-X1B1	E2E-X1B2
	5.4 mm dia.	1 mm	NPN	E2E-C1C1	E2E-C1C2
			PNP	E2E-C1B1	E2E-C1B2

■ PREWIRED SHIELDED STANDARD SENSORS

Type	Size	Sensing distance	Output configuration	Part number	
				NO	NC
	M8	1.5 mm	NPN	E2E-X1R5E1-N	E2E-X1R5E2-N
			PNP	E2E-X1R5F1-N	E2E-X1R5F2-N
	M12	2 mm	NPN	E2E-X2E1-N	E2E-X2E2-N
			PNP	E2E-X2F1-N	E2E-X2F2-N
	M18	5 mm	NPN	E2E-X5E1-N	E2E-X5E2-N
			PNP	E2E-X5F1-N	E2E-X5F2-N
	M30	10 mm	NPN	E2E-X10E1-N	E2E-X10E2-N
			PNP	E2E-X10F1-N	E2E-X10F2-N



- Note: 1. A different oscillating frequency is available. Add a “5” to the part number (e.g., E2E-X5E15-N).
 2. E2E sensors with robotic cable are available. Add a “-R” in the part number (e.g., E2E-X5E1-R-N).

■ PREWIRED UNSHIELDED STANDARD SENSORS

Type	Size	Sensing distance	Output configuration	Part number	
				NO	NC
	M8	2 mm	NPN	E2E-X2ME1-N	E2E-X2ME2-N
			PNP	E2E-X2MF1-N	E2E-X2MF2-N
	M12	5 mm	NPN	E2E-X5ME1-N	E2E-X5ME2-N
			PNP	E2E-X5MF1-N	E2E-X5MF2-N
	M18	10 mm	NPN	E2E-X10ME1-N	E2E-X10ME2-N
			PNP	E2E-X10MF1-N	E2E-X10MF2-N
	M30	18 mm	NPN	E2E-X18ME1-N	E2E-X18ME2-N
			PNP	E2E-X18MF1-N	E2E-X18MF2-N



Note: 1. A different oscillating frequency is available. Add a "5" to the part number (e.g., E2E-X5E15-N).
2. E2E sensors with robotic cable are available. Add a "-R" in the part number (e.g., E2E-X5E1-R-N).

■ SENSORS WITH BUILT-IN M12 MICROCHANGE® CONNECTOR

Type	Size	Sensing distance	Output configuration	Part number	
				NO	NC
	M8	1.5 mm	NPN	E2E-X1R5E1-M1-N	E2E-X1R5E2-M1-N
			PNP	E2E-X1R5F1-M1-N	E2E-X1R5F2-M1-N
	M12	2 mm	NPN	E2E-X2E1-M1-N	E2E-X2E2-M1-N
			PNP	E2E-X2F1-M1-N	E2E-X2F2-M1-N
	M18	5 mm	NPN	E2E-X5E1-M1-N	E2E-X5E2-M1-N
			PNP	E2E-X5F1-M1-N	E2E-X5F2-M1-N
	M30	10 mm	NPN	E2E-X10E1-M1-N	E2E-X10E2-M1-N
			PNP	E2E-X10F1-M1-N	E2E-X10F2-M1-N
	M8	2 mm	NPN	E2E-X2ME1-M1-N	E2E-X2ME2-M1-N
			PNP	E2E-X2MF1-M1-N	E2E-X2MF2-M1-N
	M12	5 mm	NPN	E2E-X5ME1-M1-N	E2E-X5ME2-M1-N
			PNP	E2E-X5MF1-M1-N	E2E-X5MF2-M1-N
	M18	10 mm	NPN	E2E-X10ME1-M1-N	E2E-X10ME2-M1-N
			PNP	E2E-X10MF1-M1-N	E2E-X10MF2-M1-N
	M30	18 mm	NPN	E2E-X18ME1-M1-N	E2E-X18ME2-M1-N
			PNP	E2E-X18MF1-M1-N	E2E-X18MF2-M1-N

Note: Connector cordsets: For MicroChange® models, use OMRON Y96E-4□D□.

■ SENSORS WITH BUILT-IN M8 NANOCHANGE® CONNECTOR

Type	Size	Sensing distance	Output configuration	Part number	
				NO	NC
	M8	1.5 mm	NPN	E2E-X1R5E1-M3	E2E-X1R5E2-M3
			PNP	E2E-X1R5F1-M3	E2E-X1R5F2-M3
	M8	2 mm	NPN	E2E-X2ME1-M3	E2E-X2ME2-M3
			PNP	E2E-X2MF1-M3	E2E-X2MF2-M3

Note: Connector cordsets: For NanoChange® models, use OMRON X3SF-M42□-40□-R or Brad Harrison equivalent.

■ ACCESSORIES

Description		Part number
Mounting brackets	Fits M8 size sensors	Y92E-B8
	Fits M12 size sensors	Y92E-B12
	Fits M18 size sensors	Y92E-B18
	Fits M30 size sensors	Y92E-B30
Silicone rubber covers for shielded sensors	Fits M12 size sensors	Y92E-E12-2
	Fits M18 size sensors	Y92E-E18-2
	Fits M30 size sensors	Y92E-E30-2

■ REPLACEMENT PARTS

Description		Part number
Mounting hardware including one pair of metal nuts and one washer	Fits M5 size sensors	M5-MHWS
	Fits M8 size sensors	M8-MHWS
	Fits M12 size sensors	M12-MHWS
	Fits M18 size sensors	M18-MHWS
	Fits M30 size sensors	M30-MHWS

Specifications

■ MINIATURE SENSORS

Part number		E2E-CR8□□	E2E-X1□□	E2E-C1□□
Size		4 mm (0.16 in) dia.	M5	5.5 mm (0.21 in) dia.
Type		Shielded		
Sensing distance		0.8 mm (0.03 in) ± 15%	1 mm (0.04 in) ± 15%	
Supply voltage		10 to 30 VDC, 10% max. permissible ripple peak to peak		
Current consumption		17 mA max.		
Sensing object		Magnetic metals		
Setting distance		0 to 0.5 mm (0 to 0.02 in)	0 to 7 mm (0 to 0.03 in)	
Standard object (mild steel, L x W x H)		5 x 5 x 1 mm (0.2 x 0.2 x 0.04 in)		8 x 8 x 1 mm (0.3 x 0.3 x 0.04 in)
Differential travel		15% max. of effective distance		
Response frequency		3 kHz		
Control output	Operation	C1 models: NPN-NO open collector C2 models: NPN-NC open collector B1 models: PNP-NO open collector B1 models: PNP-NC open collector		
	Max. load	100 mA switching capacity		
	Max. on-state voltage drop	2 VDC		
Circuit protection		DC power supply reverse polarity		
Indicators		Operation indicator (red LED)		
Ambient temperature	Operating	-25°C to 70°C (-13°F to 158°F) with no icing		
Ambient humidity	Operating	35% to 95%		
Vibration resistance		10 to 55 Hz, 1.5 mm (0.06 in) double amplitude		
Shock resistance		Approx. 50 G's		
Enclosure rating	UL	—		
	NEMA	1, 3, 4, 6, 12, 13		
	IEC 144	IP67		
Weight with cable		Approx. 30 g (1.1 oz.)		
Materials	Housing	Stainless steel	Nickel-plated brass	Nickel-plated brass
	Sensing face	Plastic PBT		
	Cable sheath	Polyvinyl chloride		

■ STANDARD SIZE SENSORS

Part number	E2E-X1R5 E□/F□-N	E2E-X2ME □/ F□-N	E2E-X2E□ / F□-N	E2E-X5ME □/F□-N	E2E-X5E□ / F□-N	E2E-X10M E□/F□-N	E2E-X10E □/ F□-N	E2E-X18M E□/ F□-N
Size	M8		M12		M18		M30	
Type	Shielded	Unshielded	Shielded	Unshielded	Shielded	Unshielded	Shielded	Unshielded
Sensing distance	1.5 mm (0.06 in) ±10%	2 mm (0.08 in) ±10%	2 mm (0.08 in) ±10%	5 mm (0.20 in) ±10%	5 mm (0.20 in) ±10%	10 mm (0.39 in) ±10%	10 mm (0.39 in) ±10%	18 mm (0.71 in) ±10%
Supply voltage (operating voltage range) (See Note 1.)	12 to 24 VDC, ripple (p-p): 10% max., (10 to 40 VDC)							
Current consumption	13 mA max.							
Sensing object	Magnetic metals (refer to <i>Engineering Data</i> for non-magnetic metals)							
Setting distance	0 to 1.2 mm (0 to 0.05 in)	0 to 1.6 mm (0 to 0.06 in)	0 to 1.6 mm (0 to 0.06 in)	0 to 4.0 mm (0 to 0.16 in)	0 to 4.0 mm (0 to 0.16 in)	0 to 8.0 mm (0 to 0.31 in)	0 to 8.0 mm (0 to 0.31 in)	0 to 14.0 mm (0 to 0.55 in)
Standard object (mild steel)	8 x 8 x 1 mm (0.31 x 0.31 x 0.04 in)	12 x 12 x 1 mm (0.47 x 0.47 x 0.04 in)	12 x 12 x 1 mm (0.47 x 0.47 x 0.04 in)	15 x 15 x 1 mm (0.59 x 0.59 x 0.04 in)	18 x 18 x 1 mm (0.71 x 0.71 x 0.04 in)	30 x 30 x 1 mm (1.18 x 1.18 x 0.04 in)	30 x 30 x 1 mm (1.18 x 1.18 x 0.04 in)	54 x 54 x 1 mm (2.13 x 2.13 x 0.04 in)
Differential travel	10% max. of sensing distance							
Response frequency	2.0 kHz	0.8 kHz	1.5 kHz	0.4 kHz	0.6 kHz	0.2 kHz	0.4 kHz	0.1 kHz
Operation (with sensing object approaching)	E1 models: Load ON E2 models: Load OFF							
Control output (switching capacity)	200 mA max.							
Circuit protection	Reverse connection protection, surge absorber, load short-circuit protection							
Indicator	Operation indicator (red LED)							
Ambient temperature (See Note 2.)	Operating: -40°C to 85°C (-40°F to 185°F) with no icing							
Ambient humidity	Operating: 35% to 95%							
Temperature influence	±15% max. of sensing distance at 23°C in temperature range of -40°C to 85°C (-40°F to 185°F) ±10% max. of sensing distance at 23°C in temperature range of -25°C to 70°C (-13°F to 158°F)							
Voltage influence	±1% max. of sensing distance in rated voltage range ±15%							
Residual voltage	2.0 V max. (under load current of 200 mA with cable length of 2 m)							
Insulation resistance	50 MΩ min. (at 500 VDC) between current carry parts and case							
Dielectric strength	1,000 VAC for 1 min. between current carry parts and case							
Vibration resistance	10 to 55 Hz, 1.5-mm double amplitude for 2 hrs each in X, Y, and Z axes							
Shock resistance	500 m/s ² (approx. 50G) for 10 times each in X, Y, and Z axes		1,000 m/s ² (approx. 50G) for 10 times each in X, Y, and Z axes 500 m/s ² (approx. 50G) for E2E-X5M					
Enclosure rating	IEC	IP67						
	NEMA	1, 4, 6, 12, 13						
Weight	Pre-wired	Approx. 45 g		Approx. 120 g		Approx. 160 g		Approx. 270 g
	Connector	---	Approx. 25 g			Approx. 45 g		Approx. 125 g
Material	Body	Stainless steel		Brass				
	Sensing face	PBT						

- Note: 1. E2E models with an M18 or M30 connector operate at a non-smoothed, all-wave rectified, mean voltage range of 24 VDC ±20%.
2. When using an E2E with an M8 connector at an ambient temperature range between 70°C and 85°C (158°F and 185°F), supply 10 to 30 VDC to the E2E and make sure that the E2E has a control output of 100 mA maximum.

Operation

OUTPUT CIRCUITS

Miniature Models

E2E-C/X□C□

NPN Output

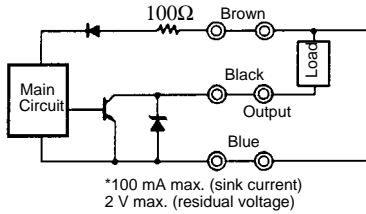

E2E-C/X□B□

PNP Output

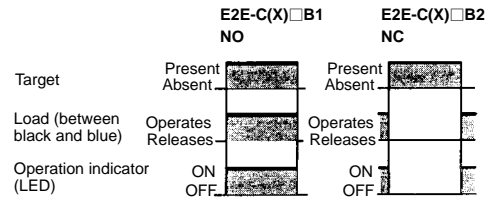
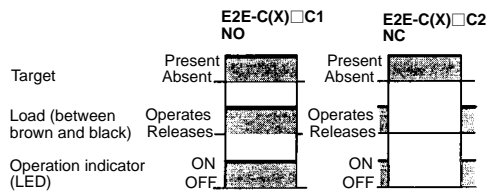
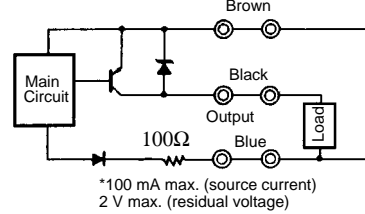

Standard Size Models

E2E-X□E□-N

NPN Output

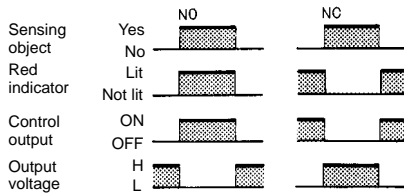
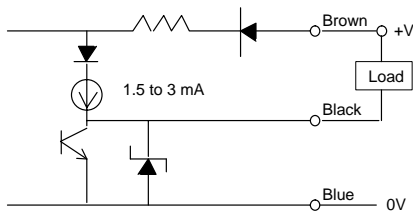

E2E-X□F□-N

PNP Output

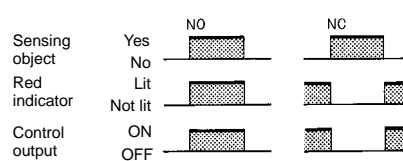
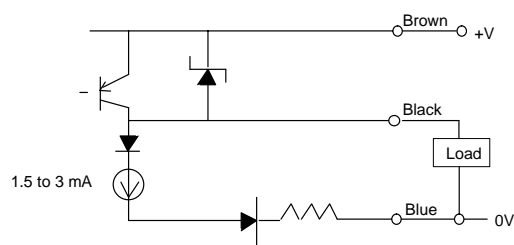

Engineering Data

OPERATING RANGE (TYPICAL)

Shielded Models

E2E-CR8□□, E2E-X1□□,
E2E-C1□□

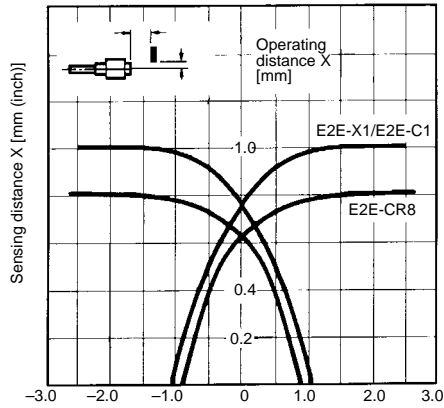

E2E-X□E□/F□-N

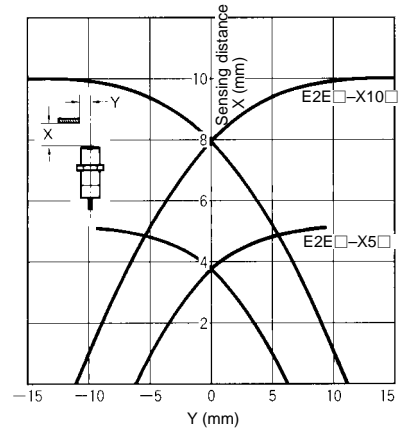
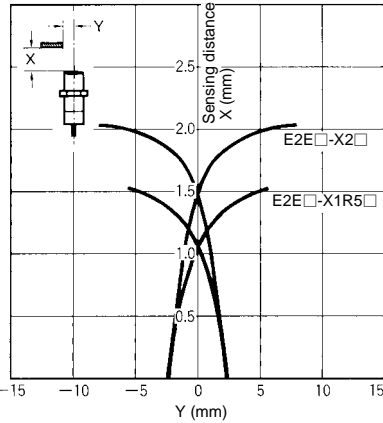

Shielded Models

E2E-X□ME□/F□-N

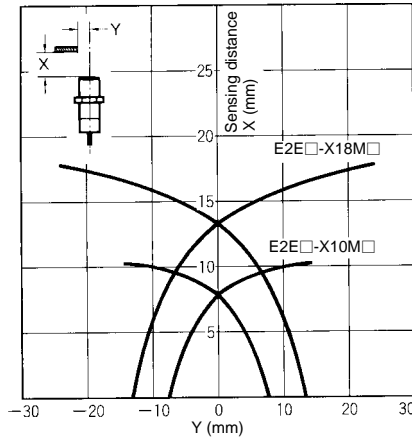
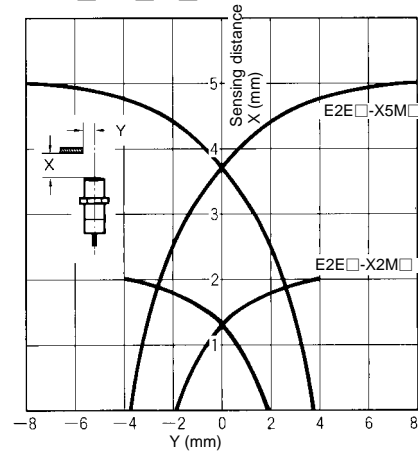

SENSING DISTANCE VS. SENSING OBJECT (TYPICAL)

E2E-CR8□□-N

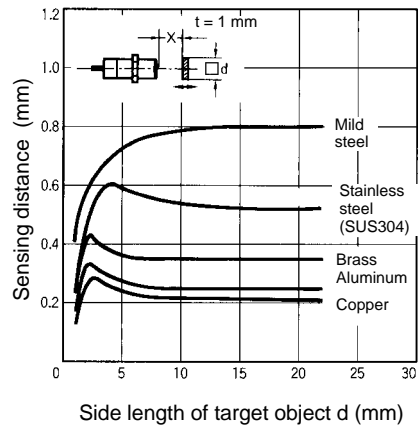

E2E-X1□□-N, E2E-C1□□-N

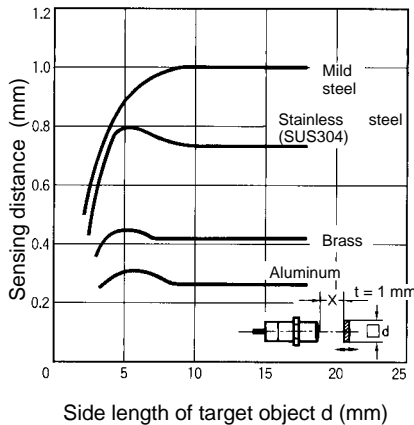

E2E-X1R5E□/F□-N

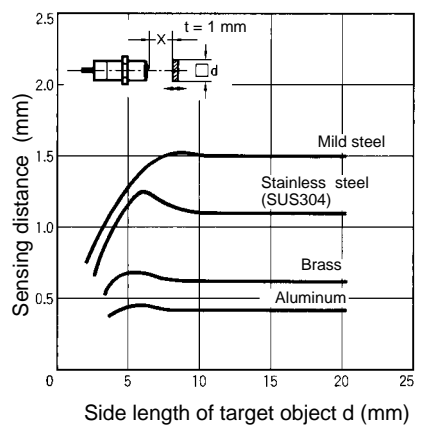

E2E-X2E□/F□-N

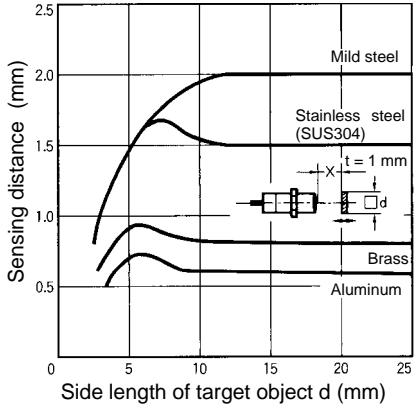

E2E-X5E□/F□-N

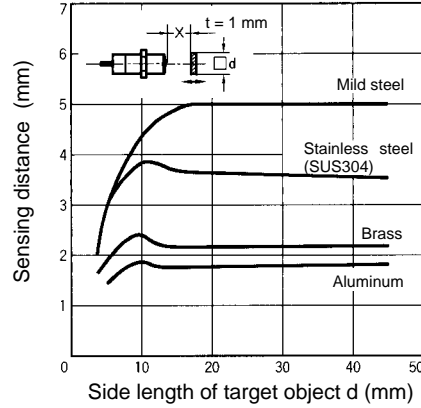

E2E-X10E□/F□-N

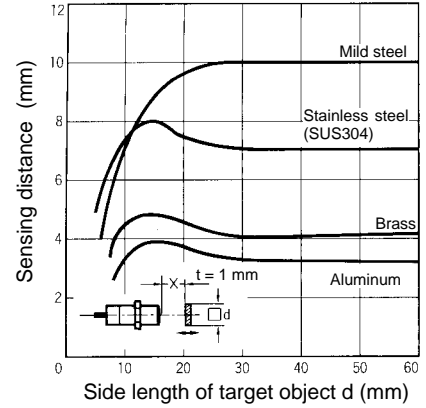

E2E-X2ME□/F□-N

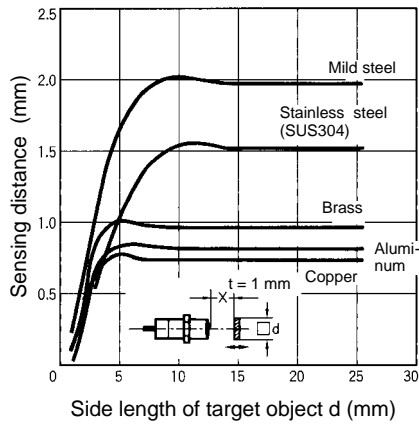

E2E-X5ME□/F□-N

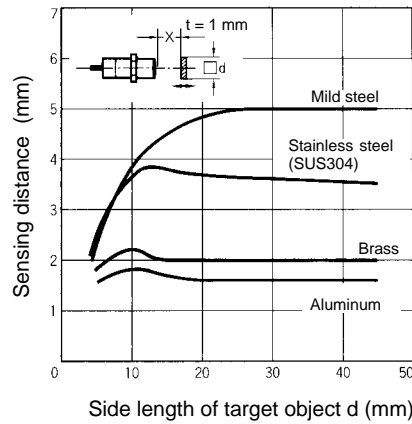

E2E-X10ME□/F□-N

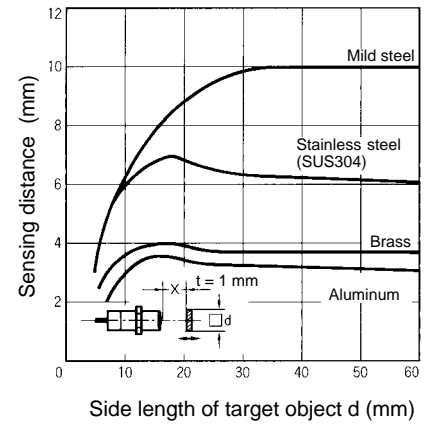

E2E-X18ME□/F□-N
E2E-X18MY□-N

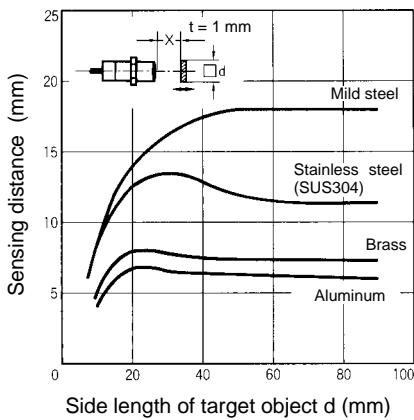

Dimensions

■ DRAWING LOCATOR

Type			Part number	Figure number
Prewired	Shielded	4 mm dia.	E2E-CR8□	1
		M5	E2E-X1□	2
		5.4 mm dia.	E2E-C1□	3
		M8	E2E-X1R5E□/F□-N	4
		M12	E2E-X2E□/F□-N	6
		M18	E2E-X5E□/F□-N	8
		M30	E2E-X10E□/F□-N	10
Prewired	Unshielded	M8	E2E-X2ME□/F□-N	5
		M12	E2E-X5ME□/F□-N	7
		M18	E2E-X10ME□/F□-N	9
		M30	E2E-X18ME□/F□-N	11
4-pin connector (M12)	Shielded	M8	E2E-XR5ME□-M1/F□-M1-N	12
		M12	E2E-X2ME□-M1/F□-M1-N	14
		M18	E2E-X5ME□-M1/F□-M1-N	16
		M30	E2E-X10ME□-M1/F□-M1-N	18
	Unshielded	M8	E2E-X2ME□-M1/F□-M1-N	13
		M12	E2E0-X5ME□-M1/F□-M1-N	15
		M18	E2E-X10ME□-M1/F□-M1-N	17
M8 connector	Shielded	M8	E2E-X1R5E□-M3/□F-M3-N	20
	Unshielded		E2E-X2ME□-M3/□F-M3-N	21

Unit: mm (inch)

■ SENSORS

Miniature Shielded DC Types

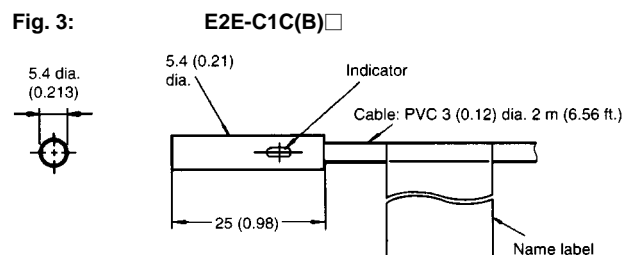
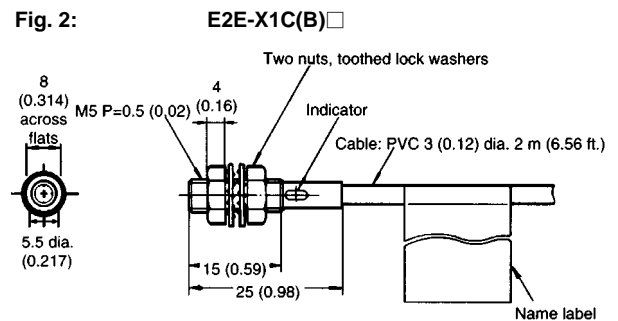
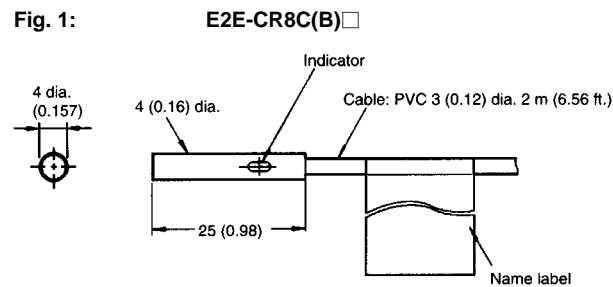

Prewired Models (Shielded)

Fig. 4:

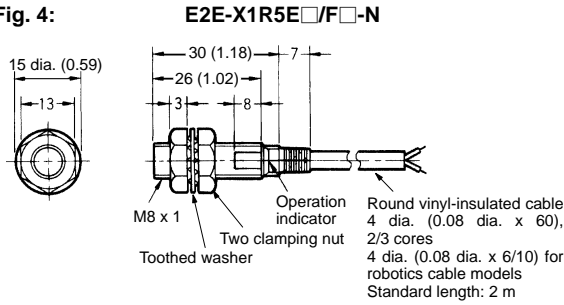

Prewired Models (Unshielded)

Fig. 5:

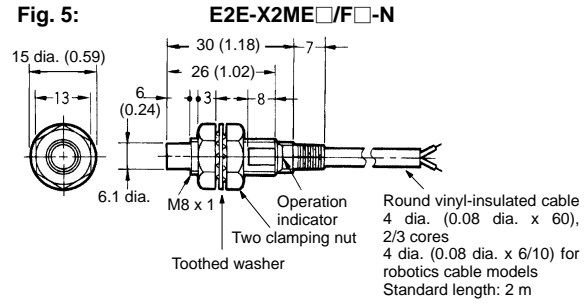

Fig. 6:

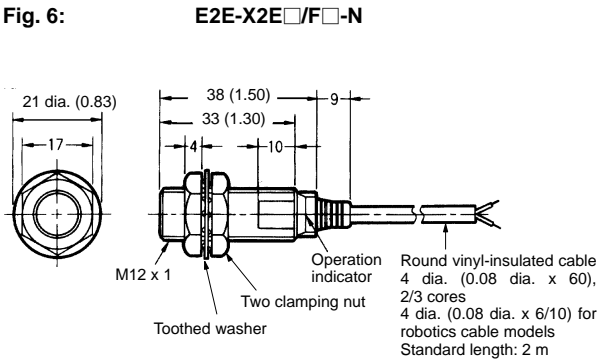

Fig.7:

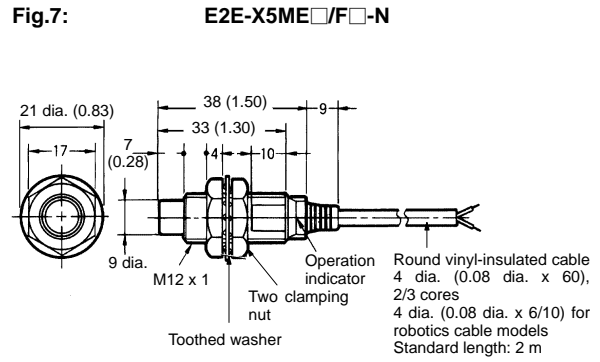

Fig. 8:

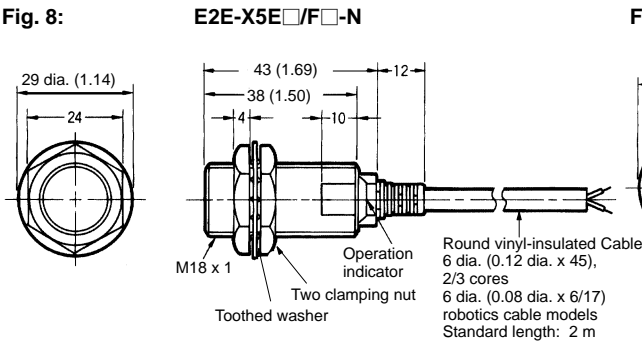

Fig. 9:

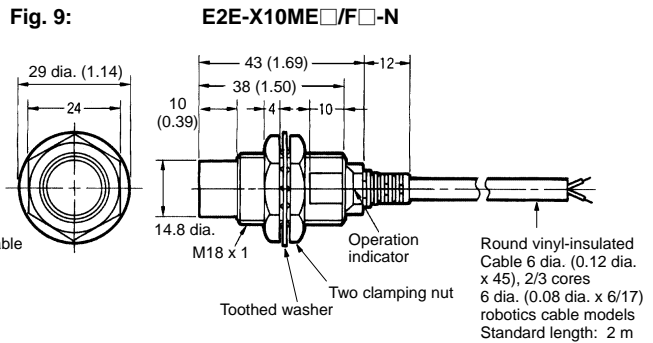

Fig. 10:

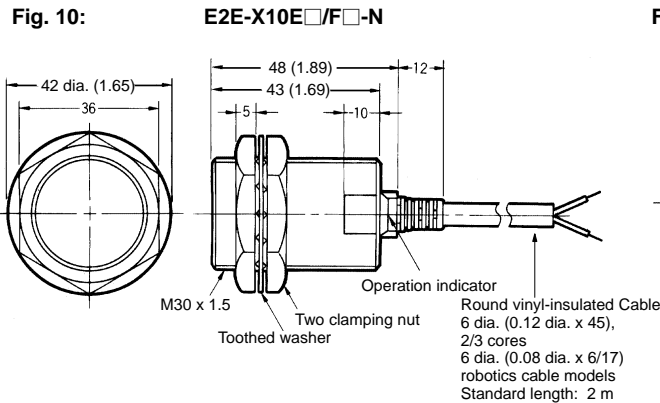
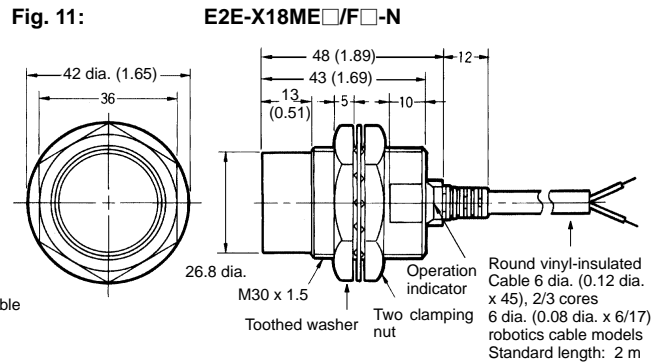

Fig. 11:



**Connector Models
(Shielded)**

Fig. 12: E2E-X1R5E□-M1/F□-M1-N

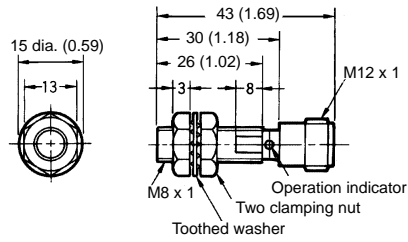

Fig. 14: E2E-X2E□-M1/F□-M1-N

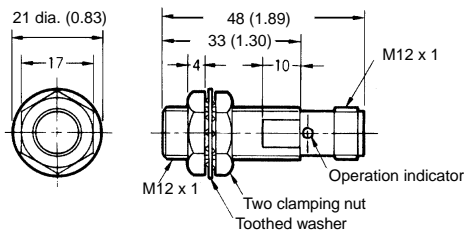

Fig. 16: E2E-X5E□-M1/F□-M1-N

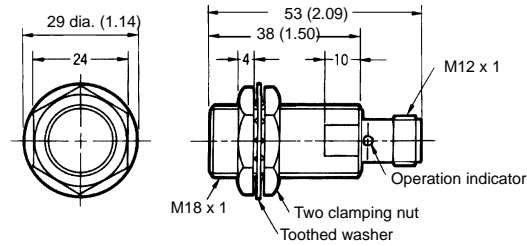
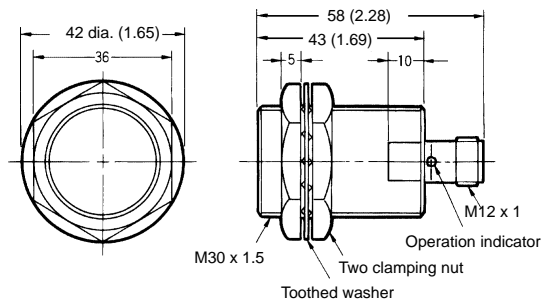

Fig.18: E2E-X10E□-M1/F□-M1-N



**Connector Models
(Unshielded)**

Fig. 13: E2E-X2ME□-M1/F□-M1-N

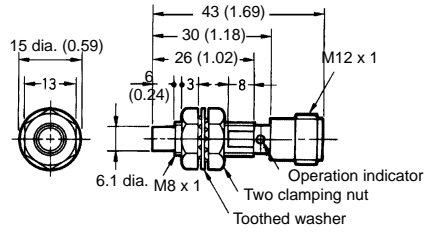

Fig. 15: E2E-X5ME□-M1/F□-M1-N

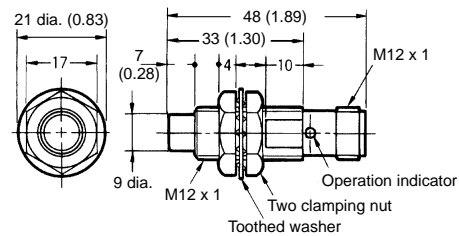

Fig.17: E2E-X10ME□-M1/F□-M1-N

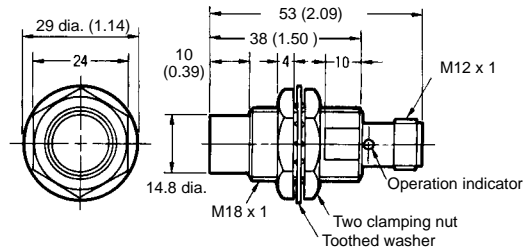
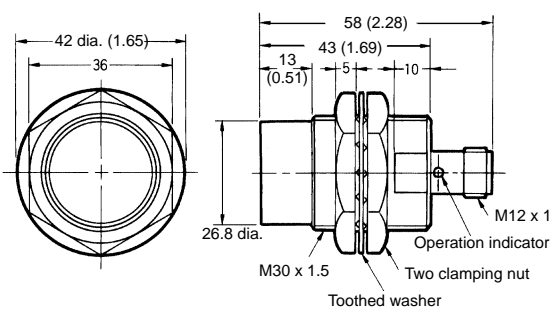
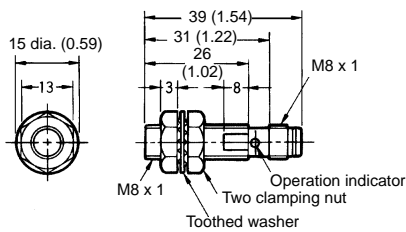

Fig. 19: E2E-X18ME□-M1/F□-M1-N



M8 Connector Models (Shielded)

Fig. 20: E2E-X1R5E□-M3/F□-M3-N



M8 Connector Models (Unshielded)

Fig. 21: E2E-X2ME□-M3/F□-M3-N

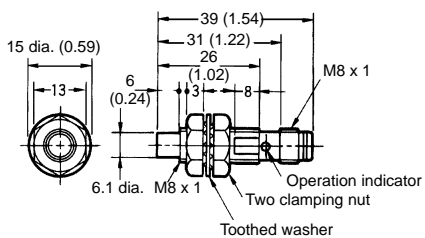

Mounting Holes

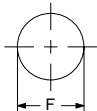

Dimensions	4 dia.	M5	5.4 dia.	M8	M12	M18	M30
F (mm)	4.2 ^{+0.5/0} dia.	5.5 ^{+0.5/0} dia.	5.7 ^{+0.5/0} dia.	8.5 ^{+0.5/0} dia.	12.5 ^{+0.5/0} dia.	18.5 ^{+0.5/0} dia.	30.5 ^{+0.5/0} dia.

Connection

■ PIN ARRANGEMENT

E2E-X□E□-M1

Connector	Output configuration	Applicable models	Pin arrangement
M12 Micro Change®	NO	E2E-X□E1-M1-N	<p>Note: Terminal 2 is not used.</p>
		E2E-X□F1-M1-N	<p>Note: Terminal 2 is not used.</p>
	NC	E2E-X□E2-M1-N	<p>Note: Terminal 4 is not used.</p>
		E2E-X□F2-M1-N	<p>Note: Terminal 4 is not used.</p>

(This table continues on the next page.)

Connector	Output configuration	Applicable models	Pin arrangement
M8 Nano Change®	NO	E2E-X□E1-M3-N	<p>Note: Terminal 2 is not used.</p>
		E2E-X□F1-M3-N	<p>Note: Terminal 2 is not used.</p>
	NC	E2E-X□E2-M3-N	<p>Note: Terminal 4 is not used.</p>
		E2E-X□F2-M3-N	<p>Note: Terminal 4 is not used.</p>

Installation

■ MOUNTING

Do not tighten the nut with excessive force. A washer must be used with the nut.

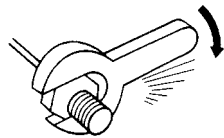

Shielded Model

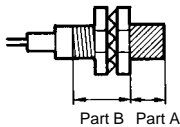

Unshielded Model

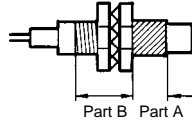

Note: The table above right shows the tightening torques for part A and part B nuts. In the previous examples, the nut is on the sensor head side (part B) and hence the tightening torque for part B applies. If this nut is in part A, the tightening torque for part A applies instead.

Type	Part A		Part B
	Length	Torque	Torque
M5	1 N • m (10 kgf • cm)		
M8	Shielded	9 mm	9 N • m (90 kgf • cm)
	Unshielded	3 mm	12 N • m (120 kgf • cm)
M12	30 N • m (310 kgf • cm)		
M18	70 N • m (710 kgf • cm)		
M30	180 N • m (1,800 kgf • cm)		

Refer to the following to mount the E2E-CR8 and E2E-C1 non-screw models.

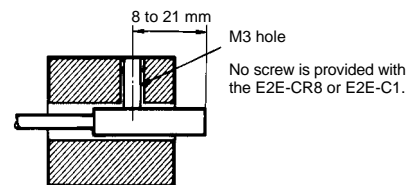

Tighten the screw to a torque of 0.20 N • m (2 kgf • cm) maximum to secure the E2E-CR8 and a torque of 0.39 N • m (4 kgf • cm) maximum to secure the E2E-C1.

■ EFFECTS OF SURROUNDING METAL

When mounting the E2E within a metal panel, ensure that the clearances given in the following table are maintained. Failure to maintain these distances may cause deterioration in the performance of the sensor.

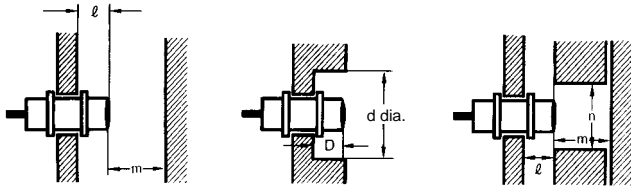

Type	Dimension	4 mm dia.	M5	5.4 mm dia.	M8	M12	M18	M30	
E2ECR8□ E2E-X1□ E2E-C1□ E2E-X□E□-N E2E-X□F□-N DC 3-wire	Shielded	l	0 mm	0 mm	0 mm	0 mm	0 mm	0 mm	
		d	4 mm	5 mm	5.4 mm	8 mm	12 mm	18 mm	30 mm
		D	0 mm	0 mm	0 mm	0 mm	0 mm	0 mm	0 mm
		m	2.9 mm	3 mm	3 mm	4.5 mm	8 mm	20 mm	40 mm
		n	6 mm	8 mm	8 mm	12 mm	18 mm	27 mm	45 mm
	Unshielded	l	—	—	—	6 mm	15 mm	22 mm	30 mm
		d	—	—	—	24 mm	40 mm	55 mm	90 mm
		D	—	—	—	6 mm	15 mm	22 mm	30 mm
		m	—	—	—	8 mm	20 mm	40 mm	70 mm
		n	—	—	—	24 mm	36 mm	54 mm	90 mm

■ MUTUAL INTERFERENCE

When installing two or more Sensors face to face or side by side, ensure that the minimum distances given in the following table are maintained.

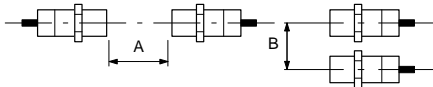

Type	Dimension	4 mm dia.	M5	5.4 mm dia.	M8	M12	M18	M30	
E2ECR8□ E2E-X1□ E2E-C1□ E2E-X□E□-N E2E-X□F□-N DC 3-wire	Shielded	A	20 mm	20 mm	20 mm	20 mm	30 (20) mm	50 (30) mm	100 (50) mm
		B	15 mm	15 mm	15 mm	15 mm	20 (12) mm	35 (18) mm	70 (35) mm
	Unshielded	A	—	—	—	80 mm	120 (60) mm	200 (100) mm	300 (100) mm
		B	—	—	—	60 mm	100 (50) mm	110 (60) mm	200 (100) mm

Note: The figures in parentheses refer to Sensors operating at different frequencies.

Precautions

■ INSTALLATION

Power Reset Time

The Proximity Sensor is ready to operate within 100 ms after power is supplied. If power supplies are connected to the Proximity Sensor and load respectively, be sure to supply power to the Proximity Sensor before supplying power to the load.

Power OFF

The Proximity Sensor may output a pulse signal when it is turned off. You must turn off the load before turning off the Proximity Sensor.

Power Supply Transformer

When using a DC power supply, make sure that the DC power supply has an insulated transformer. Do not use a DC power supply with an auto-transformer.

Sensing Object

Metal Coating

The sensing distances of the Proximity Sensor vary with the metal coating on sensing objects.

■ WIRING

High-tension Lines

Wiring through Metal Conduit

If there is a power or high-tension line near the cable of the Proximity Sensor, wire the cable through an independent metal conduit to prevent against Proximity Sensor damage or malfunctioning.

Cable Tractive Force

Do not pull cable with the tractive forces exceeding the following.

Diameter	Tractive force
4 mm dia. max.	30 N max.
4 mm dia. min.	50 N max.

■ MOUNTING

The Proximity Sensor must not be subjected to excessive shock with a hammer when it is installed, or the Proximity Sensor may be damaged or lose its water-resistance.

■ ENVIRONMENT

Water Resistance

Do not use the Proximity Sensor underwater, outdoors, or in the rain.

Operating Environment

Be sure to use the Proximity Sensor within its operating ambient temperature range and do not use the Proximity Sensor outdoors so that its reliability and life expectancy can be maintained. Although the Proximity Sensor is water resistant, a cover to protect the Proximity Sensor from water or water-soluble machining oil is recommended so that its reliability and life expectancy can be maintained. Do not use the Proximity Sensor in an environment with chemical gas (e.g., strong alkaline or acid gasses including nitric, chromic, and concentrated sulfuric acid gasses).

NOTE: DIMENSIONS SHOWN ARE IN MILLIMETERS. To convert millimeters to inches divide by 25.4.

OMRON[®]
OMRON ELECTRONICS, INC.
 One East Commerce Drive
 Schaumburg, IL 60173
1-800-55-OMRON

OMRON CANADA, INC.
 885 Milner Avenue
 Scarborough, Ontario M1B 5V8
416-286-6465