

MDSP PUSH BUTTON DIMMER SWITCHES

GENERAL ELECTRICAL & MECHANICAL SPECIFICATION

Switch Rating:	10A @ 250Vac (resistive)
Life:	>25,000 Cycles
Operating Temperature:	-25 ° C to +100 ° C
Proof Voltage:	2,500Vac (Initial)
Insulation Resistance:	>999 MΩ @ 500Vdc (Initial)
Resistance Values:	10K – 1.5MΩ
Track Rating:	0.2W
Resistance Curve:	Linear
Switch Function:	1- pole changeover
Switch Travel:	3mm
Switch Operation Force:	15N (Nominal)
Rotational angle:	270°
Operating Torque:	0.2-0.6Ncm (Standard) 0.8-1.5Ncm (Tactile version)
End Stop Torque:	40Ncm (minimum)
Fixing Nut Torque:	1.1Nm (maximum)
Perm. Axial Load:	50N (maximum)
Spindle:	Polyamide 6.6 G.F. HB Rated
Housing:	Polyamide 6.6 G.F. V0 Rated
Terminals:	Switch: Brass CZ108 Sn Plated. Potentiometer : Mild Steel Sn plated

RoHS COMPLIANT

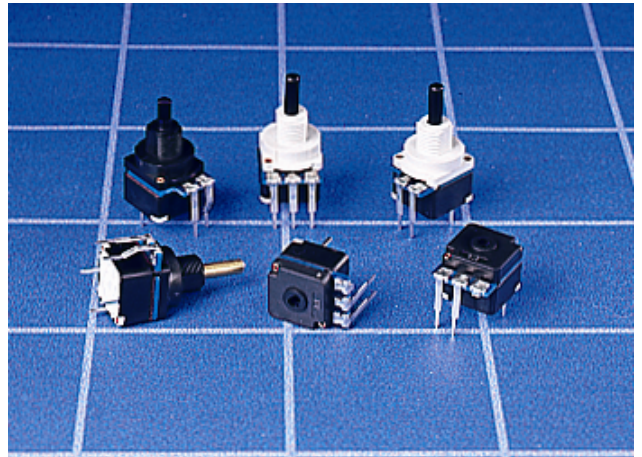

Approved to EN61058 by VDE, SEMKO, NEMKO, DEMKO, FEMKO.

GENERAL FEATURES

- Made in UK.
- Push-Push switches with rotary potentiometer in common housing.
- Printed circuit terminals.
- Used in domestic lighting dimmer controls.
- Moulded components are in UL 94V-0 rated materials.
- Wide range of resistance values available.
- **Options also available include:-**
 - Ø4.0 Metal spindle
 - Tactile Feel version (7.5° Index)
 - Alternate Switch forces available
 - AS & ES Termination available
 - Non-Linear
 - M10 x 1.0mm Bush Thread

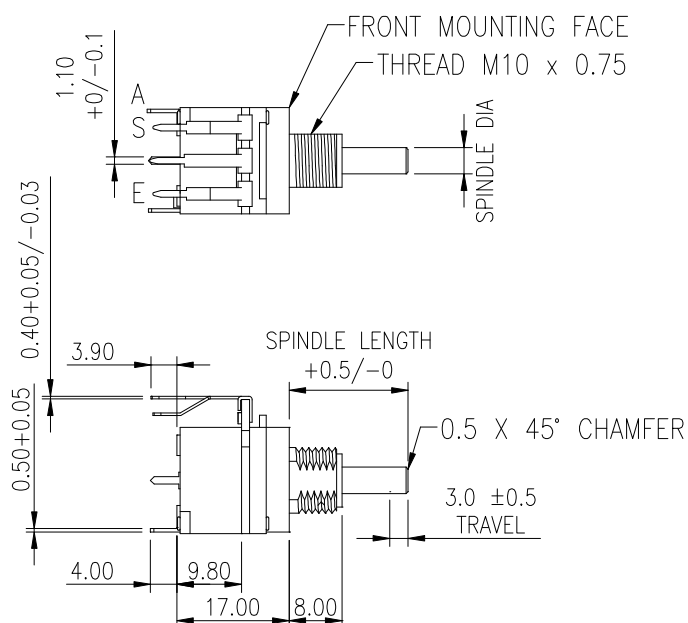

SPINDLE SIZES AVAILABLE

- 1 = Ø4.0 +0/-0.03
- 2 = Ø6.0 +0.00/-0.03

CLOCKWISE ROTATION

- 0 – max Ohms = AS
- Max – 0 Ohms = ES

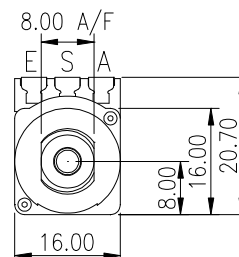

MDSP PUSH BUTTON DIMMER SWITCHES

NO BUSH VERSION

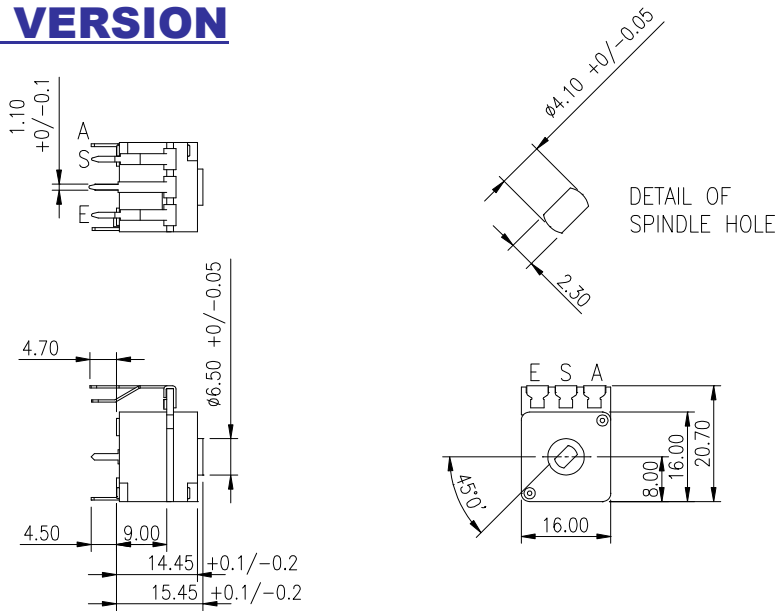

TYPICAL PCB LAYOUT

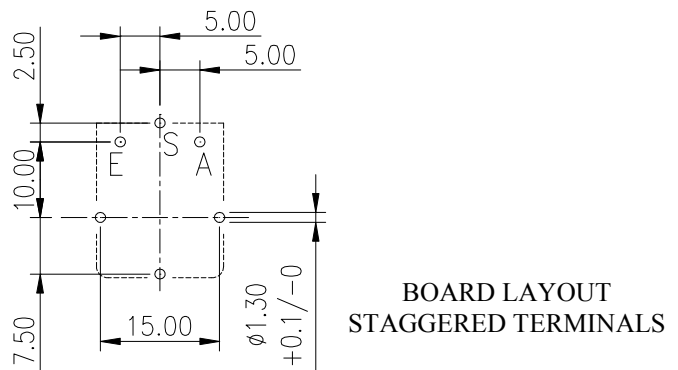
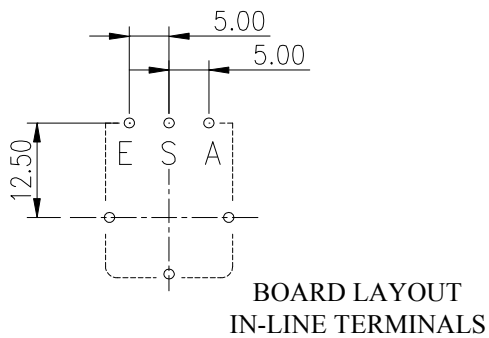

ORDERING CODE

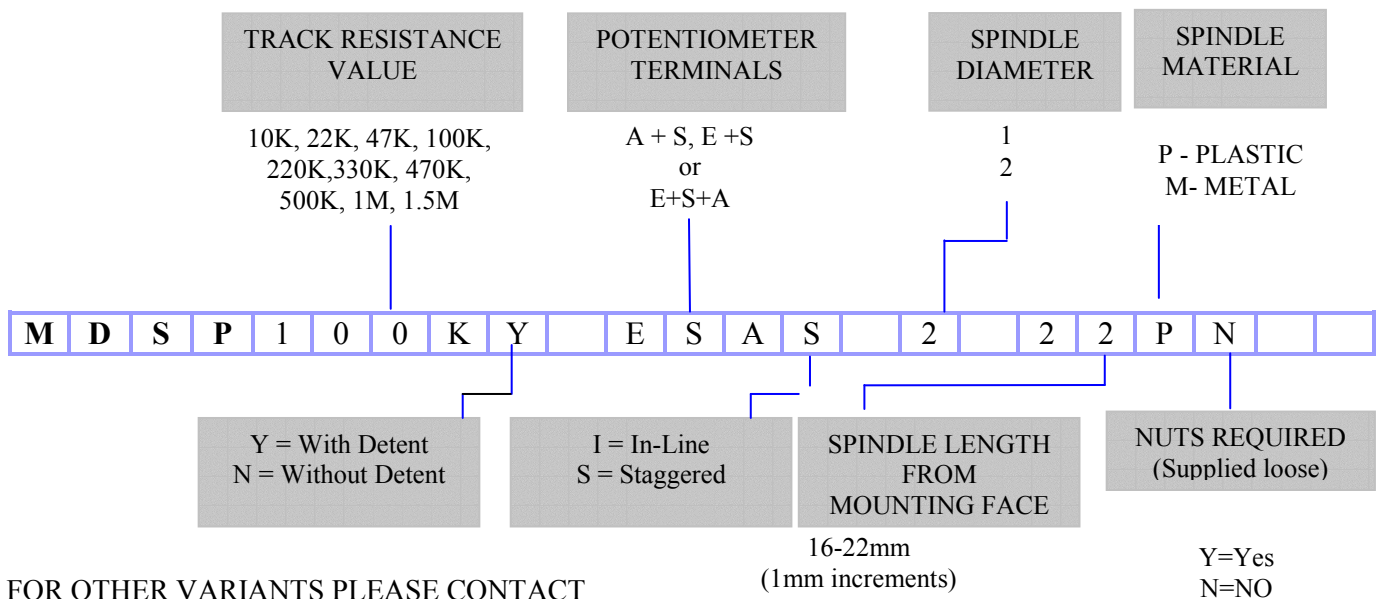

FOR OTHER VARIANTS PLEASE CONTACT OUR SALES OFFICE.