



ATTENTION

OBSERVE PRECAUTIONS
FOR HANDLING
ELECTROSTATIC
DISCHARGE
SENSITIVE
DEVICES

KAF-5060PBEEVGC

BLUE / HYPER ORANGE / GREEN

Features

- OUTSTANDING MATERIAL EFFICIENCY.
- RELIABLE AND RUGGED.
- WATER CLEAR LENS.
- LOW POWER CONSUMPTION.
- ONE BLUE , ONE ORANGE AND ONE GREEN CHIPS IN ONE PACKAGE.
- CAN PRODUCE ANY COLOR IN VISIBLE SPECTRUM, INCLUDING WHITE LIGHT.

Description

The Blue source color devices are made with InGaN on SiC Light Emitting Diode.

The Hyper Orange source color devices are made with DH InGaAlP on GaAs substrate Light Emitting Diode.

The Green source color devices are made with InGaN on SiC Light Emitting Diode.

Static electricity and surge damage the LEDs.

It is recommended to use a wrist band or anti-electrostatic glove when handling the LEDs.

All devices, equipment and machinery must be electrically grounded

Package Dimensions

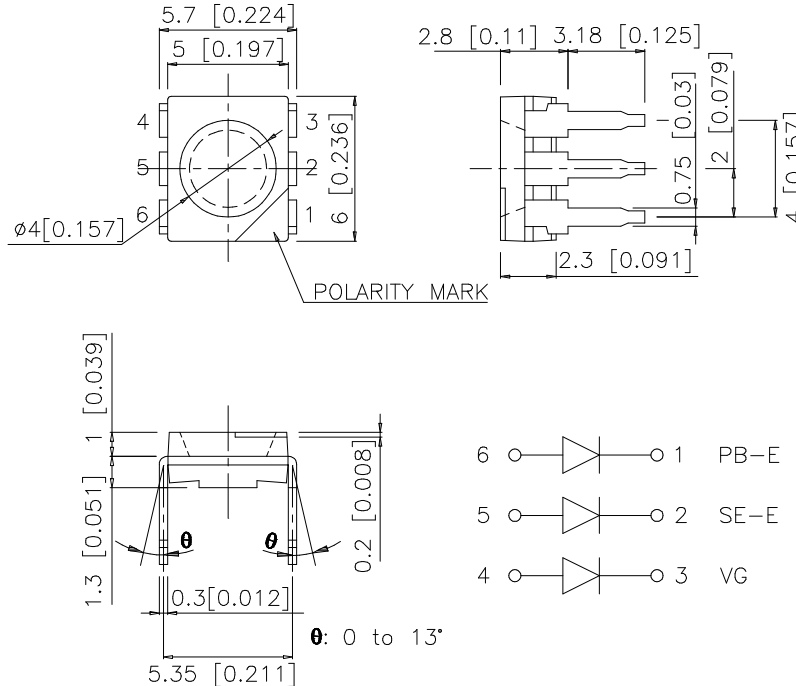

Notes:

1. All dimensions are in millimeters (inches).
2. Tolerance is $\pm 0.25(0.01")$ unless otherwise noted.
3. Lead spacing is measured where the lead emerge package.
4. Specifications are subject to change without notice.

Selection Guide

Part No.	Dice	Lens Type	Iv (mcd) @ 30mA *50mA		Viewing Angle
			Min.	Typ.	2θ1/2
KAF-5060PBESEEVGC	BLUE (InGaN)	WATER CLEAR	110	250	100°
	HYPER ORANGE(InGaAlP)		*650	*1000	
	GREEN (InGaN)		180	350	

Notes:

1. θ1/2 is the angle from optical centerline where the luminous intensity is 1/2 the optical centerline value.
2. * Luminous intensity with asterisk is measured at 50mA.

Electrical / Optical Characteristics at T_A=25°C

Symbol	Parameter	Device	Typ.	Max.	Units	Test Conditions
λ _{peak}	Peak Wavelength	Blue Hyper Orange Green	465 630 520		nm	I _F =20mA
λ _D	Dominate Wavelength	Blue Hyper Orange Green	470 621 525		nm	I _F =20mA
Δλ _{1/2}	Spectral Line Half-width	Blue Hyper Orange Green	25 20 38		nm	I _F =20mA
C	Capacitance	Blue Hyper Orange Green	110 25 45		pF	V _F =0V;f=1MHz
V _F	Forward Voltage	Blue Hyper Orange Green	3.7 2.0 4.0	4.3 2.5 4.5	V	I _F =20mA
I _R	Reverse Current	All		10	μA	V _R = 5V

Absolute Maximum Ratings at T_A=25°C

Parameter	Blue	Hyper Orange	Green	Units
Total Power dissipation [1]	350			mW
DC Forward Current	30	50	30	mA
Peak Forward Current [2]	160	195	150	mA
Reverse Voltage	5	5	5	V
Operating/Storage Temperature	-40°C To +85°C			
Lead Solder Temperature [3]	260°C For 5 Seconds			

Notes:

1. Within 350mW at all chips are lightened.
2. 1/10 Duty Cycle, 0.1ms Pulse Width.
3. 2mm below package base.

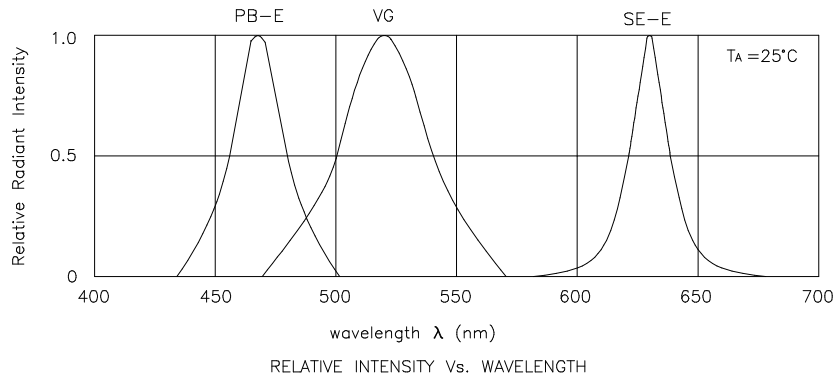

KAF-5060PBESEEVGC Blue

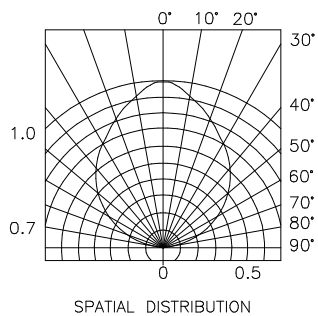
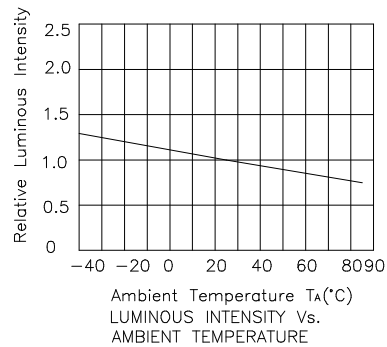
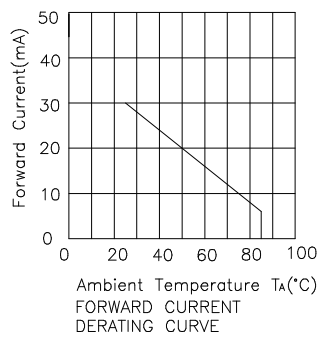
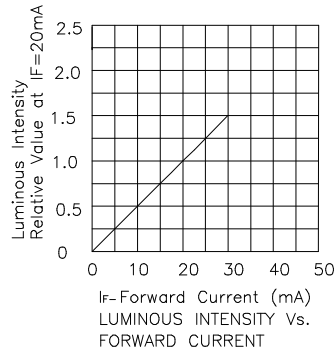
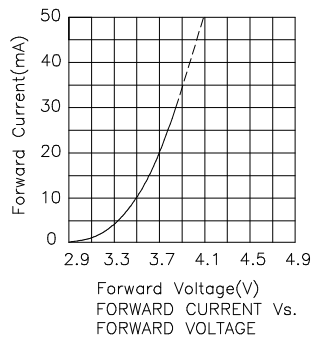

Hyper Orange

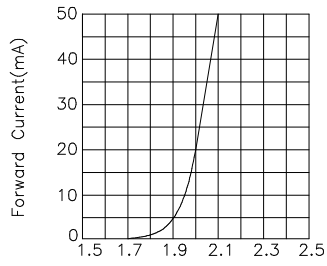

Forward Voltage(V)
FORWARD CURRENT Vs.
FORWARD VOLTAGE

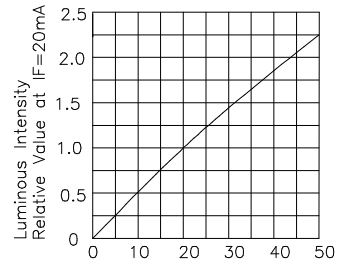

I_f -Forward Current (mA)
LUMINOUS INTENSITY Vs.
FORWARD CURRENT

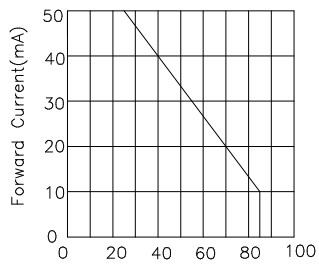

Ambient Temperature T_a (°C)
FORWARD CURRENT
DERATING CURVE

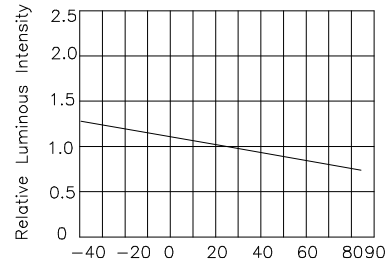

Ambient Temperature T_a (°C)
LUMINOUS INTENSITY Vs.
AMBIENT TEMPERATURE

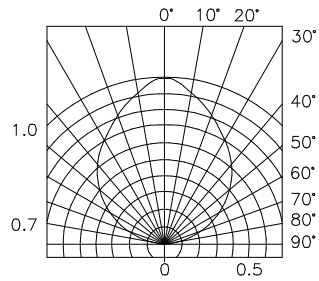

SPATIAL DISTRIBUTION

Green

