

Deckel

* = Mass durch Formkonizität nach unten verringert.
Freimass – Toleranz nach GTA 13/5 DIN 1688

Zylinderschraube M4 x 20/7
ähnl. DIN EN ISO 1207

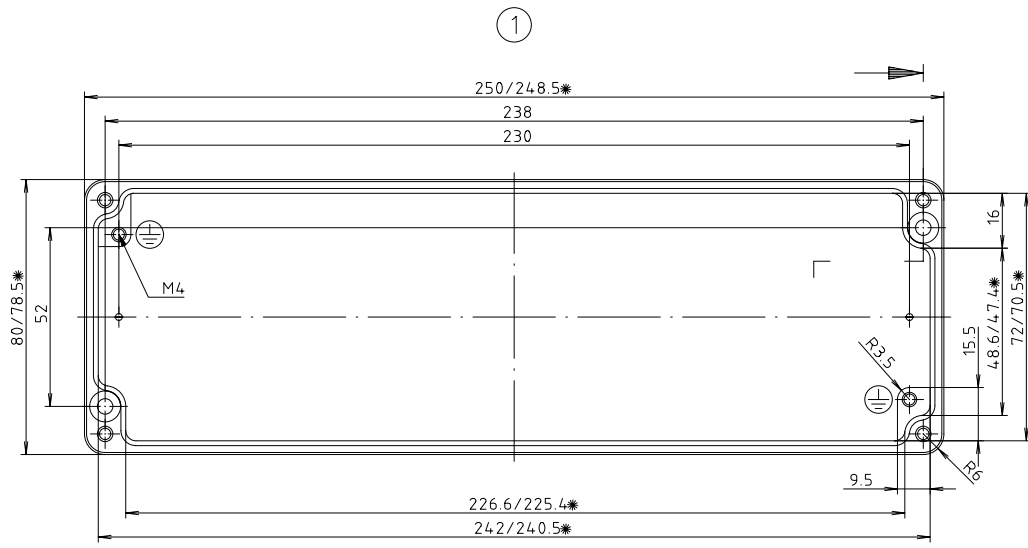

Unterteil

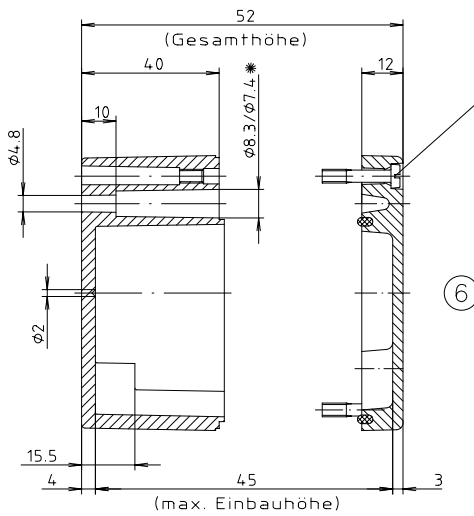

"Schutzvermerk nach DIN 34 beachten"

Konvertierung nicht zulässig!	
Maßstab: 1:1	
Zchn.Nr: 2K 117.003.02	
Artikel: A117 / 01.082505 Katalogzeichnung	
3587	11.12.01
Ae.Nr: Datum:	DISK : 2 4 01 720 Datum: 27.04.99 HR



A Phoenix Mecano Company