

Absolute Encoders with BCD and Gray Code Output

- 360° position model with BCD output allows detection of shaft angle in units of 1°
- Gray code output model offers 256 pulses per revolution for 8-bit resolution
- Rugged construction: 10 mm (0.4 inch) diameter shaft with radial load ratings of 10 kgf (72.3 ft•lbs) and axial load rating of 3 kg (21.7 ft•lbs)
- High speed, high precision positioning with programmable control when used in combination with Omron's H8PR or H8PS Cam Positioners



Ordering Information

■ ENCODERS

Encoders with a "-C" in the part number have a cable that terminates in a connector for Omron's H8PS and H8PR Cam Positioners.

Resolution (pulses/revolution)	Output code	Output form	Supply voltage	Cable termination	Part number
10-bit (360 pulses/revolution)	BCD	Open collector	5 to 12 VDC	Wire bundle	E6F-AB3C 360 2M
				Connector	E6F-AB3C-C 360 2M
8-bit (256 pulses/revolution)	Gray code	Open collector	12 to 24 VDC	Connector	E6F-AG5C-C

■ ACCESSORIES

Description	Part number
Shaft coupler (supplied with E6F-AB3C 360 2M only)	E69-C10B
Extension cable, 5 m (16.40 ft) for E6F-AB3C-C 360 2M and E6F-AG5C-C encoders	E69-DF5

■ REPLACEMENT PARTS

Description	Part number
Mounting brackets (set of 3) supplied with each E6F encoder	E69-FCA-02

Specifications

Part number	E6F-AB3C 360 2M	E6F-AB3C-C 360 2M	E6F-AG5C-C
Supply voltage	5 VDC -5% to 12 VDC +10%; max. 5% ripple peak-to-peak		12 VDC -10% to 24 VDC +15%; max. 5% ripple peak-to-peak
Current consumption	100 mA max.		70 mA max.
Resolution (pulses/revolution)	10-bit (360 pulses/revolution)		8-bit (256 pulses/revolution)
Output code	BCD		Gray code
Applicable Cam Positioner	—	H8PS	H8PR
Output form	Open collector output		Open collector output
Output capacity	Applied voltage: 30 VDC max. Residual voltage: 0.4 V max. at sink current Sink current: 35 mA max.		Applied voltage: 28 VDC Residual voltage: 0.4 V max. at sink current Sink current: 16 mA max.
Maximum response frequency	10 kHz		10 kHz
Logic	Negative (H level: 0, L level: 1)		
Accuracy	±0.5° max.		± 1°
Rotation direction	Output code increased in clockwise direction when viewed from shaft		
Output rise and fall times	1.0 μs max. with 5 V control output voltage, 470 Ω load resistance and 2 m (6.56 ft) output cable 2.0 μs max. with 5 V control output voltage, 1 kΩ load resistance and 2 m (6.56 ft) output cable		
Starting torque	100 g·cm (1.39 oz·inch) max.		
Shaft loading	Radial	10 kgf (72.3 ft·lbs)	
	Axial	3 kgf (21.7 ft·lbs)	
Moment of inertia	15 g·cm ² (0.082 oz·inch ²) max.		
Maximum rpm	5,000 rpm		
Electrical connection	Prewired with 2 m (6.56 ft.) length cable		Connector
Weight	Approx. 500 g (1.1 lb.)		
Enclosure rating	IEC: IP52F (dust-proof, drip-proof)		
Ambient temperature	Operating	-10°C to 70°C (14°F to 158°F)	
	Storage	-25°C to 80°C (-13°F to 176°F)	
Ambient humidity	35% to 85% RH		
Vibration resistance	Mechanical durability: 10 to 55 Hz, 1.5 mm double amplitude, in X, Y, and Z directions for 2 hours each		
Shock resistance	Mechanical durability: approx. 100 G in X, Y, and Z directions, 3 times each		
Insulation resistance	10 MΩ minimum at 500 VDC between current-carrying part and housing		
Dielectric strength	500 VAC, 50/60 Hz for 1 minute between current-carrying part and housing		

Operation

■ OUTPUT CIRCUIT DIAGRAM

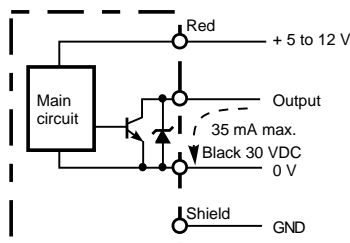

Wiring

Wire color	E6F-AB3C	Pin no.	E6F-AB3C-C	E6F-AG5C-C
Red	+ power supply	1	2 ⁰	} Internally connected
Black	0 V (common)	2	2 ¹	
Brown	2 ⁰	3	2 ²	2 ⁵
Orange	2 ¹	4	2 ³	2 ¹
Yellow	2 ²	5	2 ⁰ x 10	2 ⁰
Green	2 ³	6	2 ¹ x 10	2 ⁷
Blue	2 ⁰ x 10	7	2 ² x 10	2 ⁴
Purple	2 ¹ x 10	8	2 ³ x 10	2 ²
Gray	2 ² x 10	9	2 ⁰ x 100	2 ³
White	2 ³ x 10	10	2 ¹ x 100	2 ⁶
Pink	2 ¹ x 100	11	GND	Shield
Light Blue	2 ² x 100	12	Power supply 5~12V	Power supply 12~24V
Shield	GND	13	0V (common)	0V (common)

■ TIMING CHART

Shaft rotation: Clockwise as viewed from the shaft

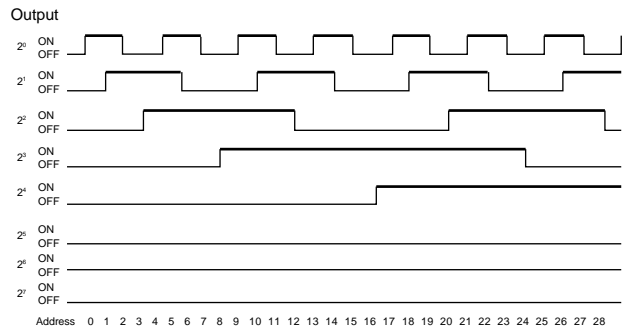
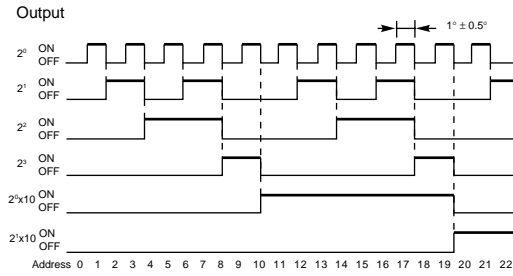

Dimensions

Unit: mm (inch)

■ ENCODERS

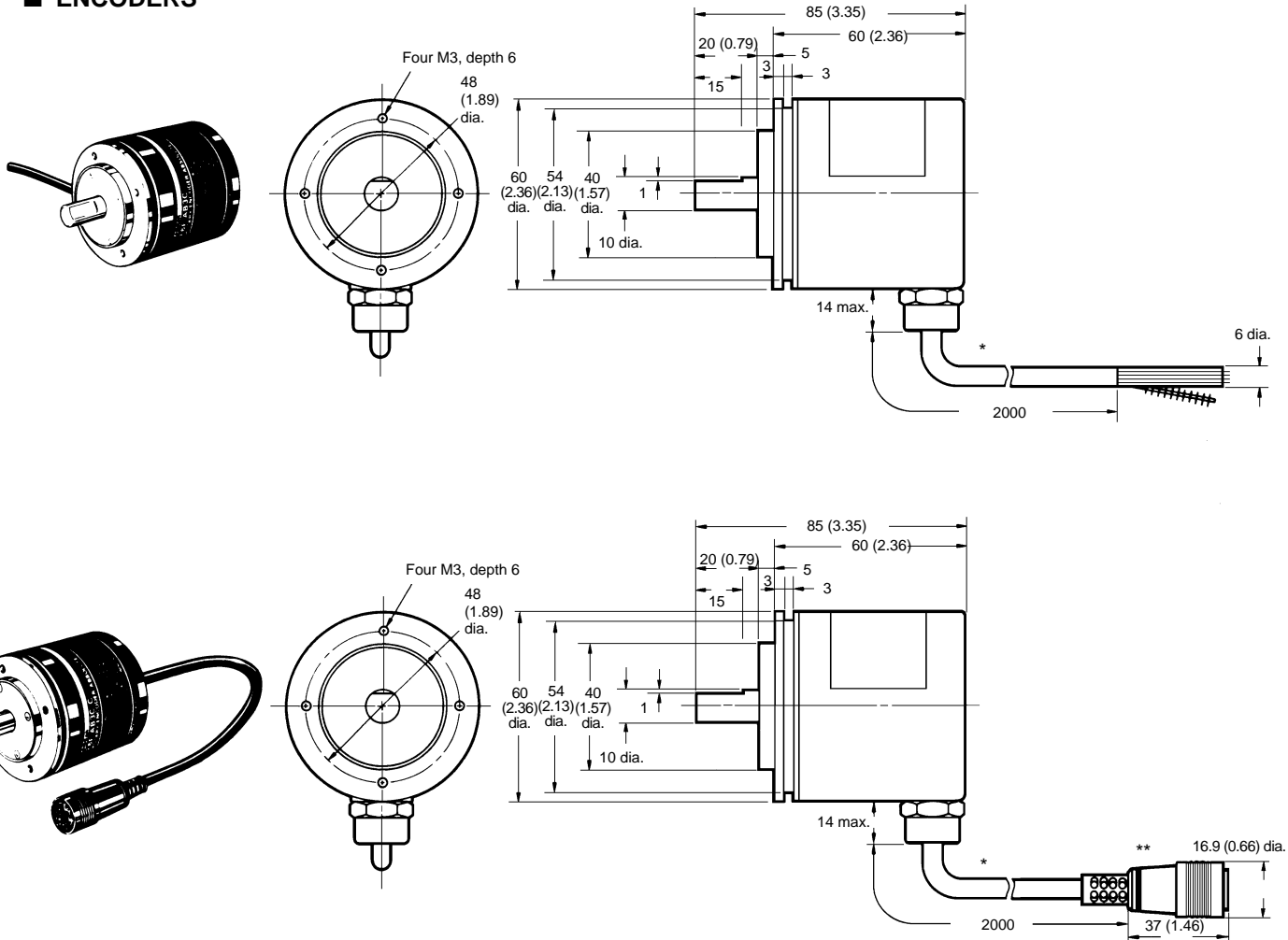

Note:
 * Oil-resistant, vinyl-insulated and shielded cable is 2 m (6.56 ft) long. The E6F-AB3C encoder terminates with a 6 mm OD wire bundle.
 **E6F-AB3C-C and E6F-AG5C-C encoders terminate in a connector that fits H8PR and H8PS Cam Positioners.

■ MOUNTING BRACKET E69-FCA-02

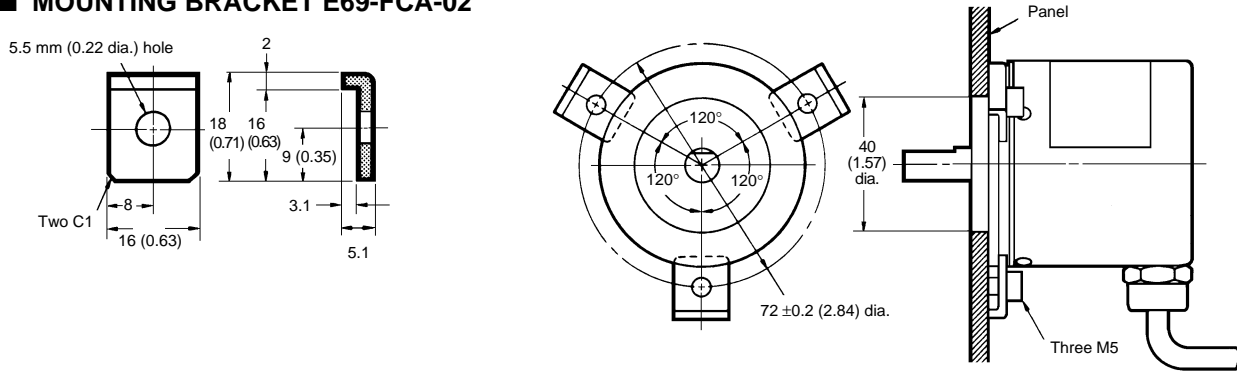

■ ACCESSORIES

Shaft Coupler E69-C10B

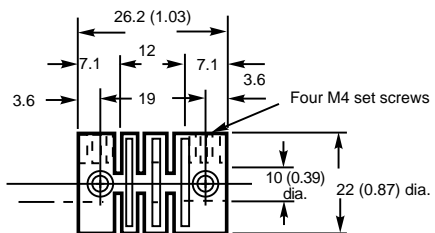

Note:

1. Material: Glass-filled polybutadiene terephthalate (PBT).
2. A coupler is supplied with E6F-AB3C encoder.
3. Each set screw must be tightened to 2.5 kg-cm (2.17 in-lbs)

Extension Cable E69-DF5

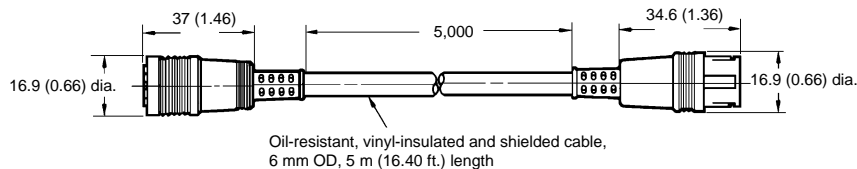

NOTE: DIMENSIONS ARE SHOWN IN MILLIMETERS. To convert millimeters to inches divide by 25.4.

OMRON

OMRON ELECTRONICS, INC.

One East Commerce Drive
Schaumburg, IL 60173

1-800-55-OMRON

4

Cat. No. CEDSAX3

10/99

Specifications subject to change without notice.

OMRON CANADA, INC.

885 Milner Avenue
Scarborough, Ontario M1B 5V8

416-286-6465

Printed in the U.S.A.