

[Codes/Dimensions](#)

ABOX



Big selling success from the RETEX range of plastic professional cases.

Desktop cases moulded in ABS, with 2 mm thick silver anodized aluminium panels.

Specially designed for equipment such as intercoms, displays, test or control units.

Bases incorporate bosses for mounting PCB and Eurocards.

Supplied: four non-slip feet.

Standard colours: light grey similar to RAL 7032 and black similar to RAL 9004.

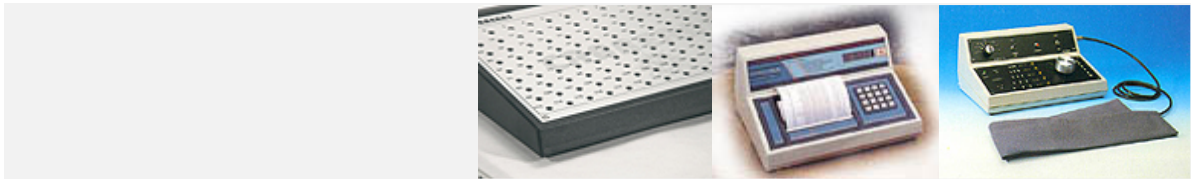

ABOX 1

Sloped case, small sized control equipments.

[DOWNLOAD DRAWING ABOX 1 \(PDF 47K\)](#)



ABOX 2

Sloped case, medium sized control equipments.

[DOWNLOAD DRAWING ABOX 2 \(PDF 79K\)](#)



ABOX 3

Two-panel configuration case, medium sized control equipments.

[DOWNLOAD DRAWING ABOX 3 \(PDF 88K\)](#)





ABOX 4

Sloped case, wide display control equipments.

DOWNLOAD DRAWING ABOX 4 (PDF 87K)



ABOX 5

Two-panel configuration case, wide display control equipments.

DOWNLOAD DRAWING ABOX 5 (PDF 98K)



ALZADO POST. DESMONTADO
REAR VIEW (OPENED)

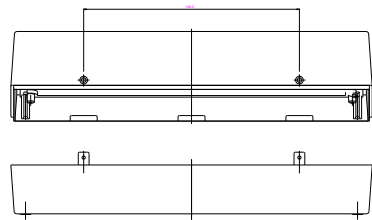

ALZADO LATERAL
SIDE VIEW

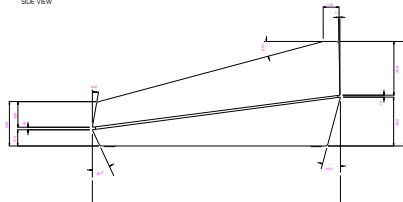

Sección 1 (DIMENSIONES INTERIORES)
Section 1 (INSIDE DIMENSIONS)

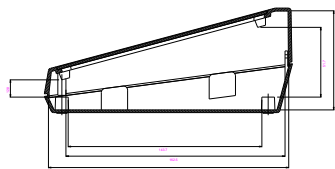

Sección 1 (DESPEQUE)
Section 1 (PARTS)

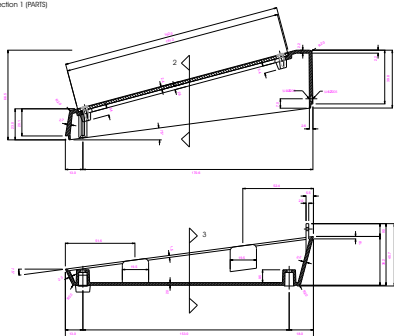

PLANTA SUPERIOR
PLANT VIEW

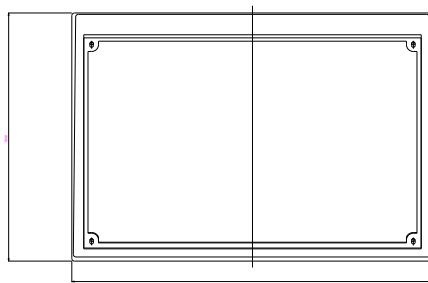

ALZADO FRONTAL
FRONTAL VIEW

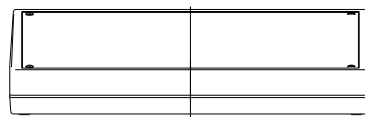

BASE: PLANTA INTERIOR
BOTTOM: INSIDE VIEW

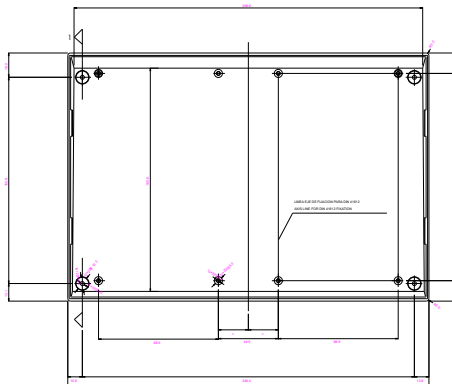

PIE
FOOT



TORNILLO PARA PANEL 1/4"x2.9x9.5 (2/1)
1/4"x2.9x9.5 PANEL BOLT (2/1)



Sección 2
Section 2



Sección 3
Section 3

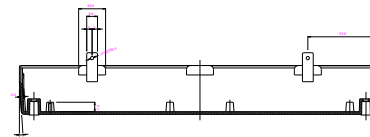

PANEL
PANEL



FORMADO DE CARSA SEGUN DIN 41612. LAS TORREJAS EN LA BASE DE SA.2 PERMITEN
EL MONTAJE DE DOS CARSA.
DIN 41612 CARSA FORMAL: BOSES ON SA.2 BOTTOM ALLOW MOUNTING TWO CARSA.

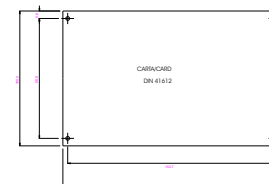

PROYECTO: []		FECHA: []	
AUTOR: []		REVISOR: []	
APROBADO: []		FECHA: []	

NO.	DESCRIPCION	FECHA	ELABORADO	REVISADO	APROBADO
1

PROYECTO: []
 FECHA: []
 AUTOR: []
 REVISOR: []
 APROBADO: []