

RoHS  **PMT3(310) Series**

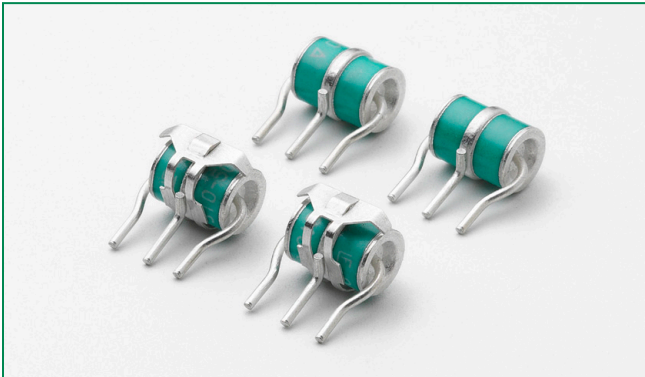

### Description

Littelfuse three electrode PMT3(310) series GDTs are designed primarily to protect telecommunications equipment requiring simultaneous crowbar action of two signal lines. GDTs function as switches; dissipating a minimum amount of energy and can handle much higher currents than other types of transient voltage protection.

### Features

- Rugged ceramic-metal construction
- Available with or without leads
- Low capacitance (<1.5 pF)
- Available with various lead spacings
- Available with or without fail-safe clip
- Tested to REA PE-80

### Agency Approvals

AGENCY	AGENCY FILE NUMBER
	E128662

### 3 Electrode GDT Graphical Symbol

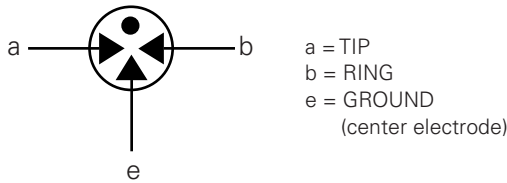

### Applications

- Telephone interface
- Modems
- Telephone line cards
- Line test equipment
- Repeaters

### Electrical Characteristics

Part Number	Device Specifications						Life Ratings						
	DC Breakdown (I-g) @500V/μs			DC Voltage 100 V/μSec.	DC Voltage 1kV/μSec.	Insulation Resistance Min	Capacitance (@1Mhz)	AC Current 11 cycles @ 50-60Hz <sup>1</sup>	AC Current 50Hz 1Sec. x10 <sup>1</sup>	Surge Current 8/20μSec x10 <sup>1</sup>	Max Single Surge 8/20 μSec <sup>1</sup>	Max Single Surge 10/350 μSec <sup>1</sup>	Surge Life 10/1000 μSec x 400 <sup>1</sup>
	Min	Typ	Max										
PMT3(310)090	72	90	108	500	650	10 <sup>10</sup> Ω (at 50V)	1.5 pf	130Amps	20Amps	20kA	25kA	5kA	1kA
PMT3(310)150	120	150	180	500	600	10 <sup>10</sup> Ω (at 100V)							
PMT3(310)230	184	230	276	600	700								
PMT3(310)250	200	250	300	600	700								
PMT3(310)350	280	350	420	900	1000								
PMT3(310)400	320	400	480	900	1000								
PMT3(310)500	400	500	600	1100	1200								

NOTES:

1. Total current through center electrode, tested in accordance with ITU-T Rec K.12 and REA PE 80  
End of life DC: 50% of minimum initial DC breakdown voltage to 150% of maximum initial DC breakdown voltage limit.  
Impulse: less than 150% of initial impulse breakdown down limit.

### Product Characteristics

<b>Materials</b>	Dull Tin Plate 17.5 ± 12.5 Microns with Ceramic Insulator
<b>Product Marking</b>	Littelfuse 'LF' marking, Voltage and date code.
<b>Glow to arc transition current</b>	~ 1Amp
<b>Glow Voltage</b>	~ 60-200 Volts

<b>Storage and Operational Temperature</b>	-40 to +90°C
<b>Transverse Voltage (Delay Time)</b> Tested to ITU-T Rec. K.12	< 0.2µSec
<b>Arc Voltage</b>	~ 10 to 35 Volts
<b>Holdover Voltage</b> Tested to ITU-T Rec. K.12 & REA PE 80	< 150mS

### Soldering Parameters - Reflow Soldering (Surface Mount Devices)

Reflow Condition		Pb – Free assembly
Pre Heat	- Temperature Min ( $T_{s(min)}$ )	150°C
	- Temperature Max ( $T_{s(max)}$ )	200°C
	- Time (Min to Max) ( $t_s$ )	60 – 180 secs
Average ramp up rate (Liquidus Temp ( $T_L$ ) to peak)		3°C/second max
$T_{s(max)}$ to $T_L$ - Ramp-up Rate		5°C/second max
Reflow	- Temperature ( $T_L$ ) (Liquidus)	217°C
	- Temperature ( $t_L$ )	60 – 150 seconds
Peak Temperature ( $T_p$ )		260 <sup>+0/-5</sup> °C
Time within 5°C of actual peak Temperature ( $t_p$ )		10 – 30 seconds
Ramp-down Rate		6°C/second max
Time 25°C to peak Temperature ( $T_p$ )		8 minutes Max.
Do not exceed		260°C

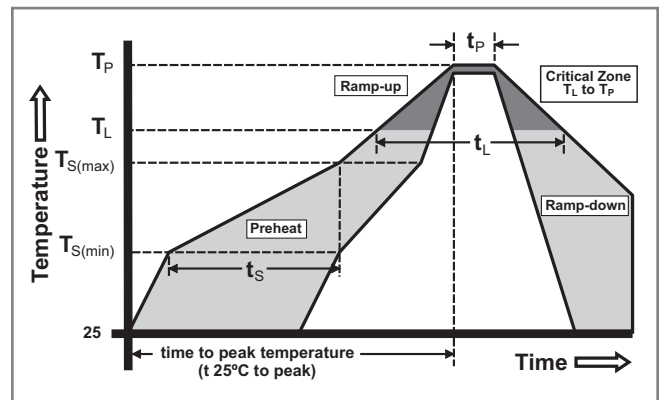

### Soldering Parameters - Hand Soldering

Solder Iron Temperature: 350° C +/- 5°C  
 Heating Time: 5 seconds max.

### Soldering Parameters - Wave Soldering (Thru-Hole Devices)

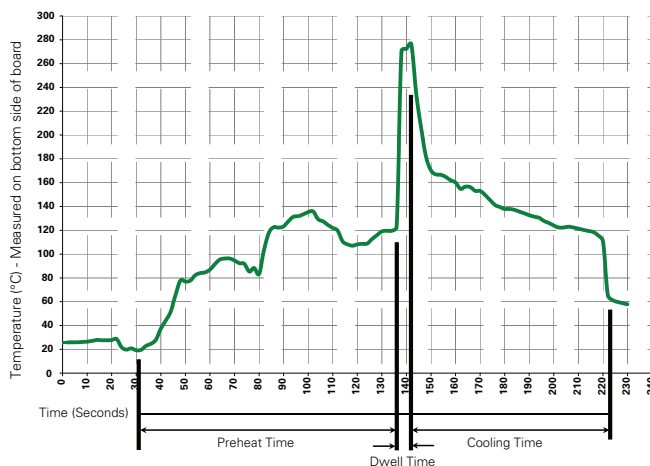

### Recommended Process Parameters:

Wave Parameter	Lead-Free Recommendation
<b>Preheat:</b> (Depends on Flux Activation Temperature)	
Temperature Minimum:	100° C
Temperature Maximum:	150° C
Preheat Time:	60-180 seconds
<b>Solder Pot Temperature:</b>	280° C Maximum
<b>Solder Dwell Time:</b>	2-5 seconds

Note: Surge Arrestors with a Failsafe mechanism should be individually examined after soldering

### Device Dimensions

NOTE: Failsafe option dimensions shown in green.

#### Type 01 - Surface Mount Core

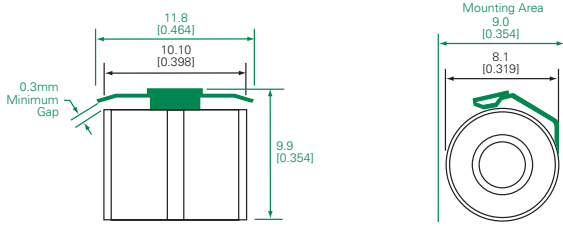

#### Type 04 - Shaped Radial Leads

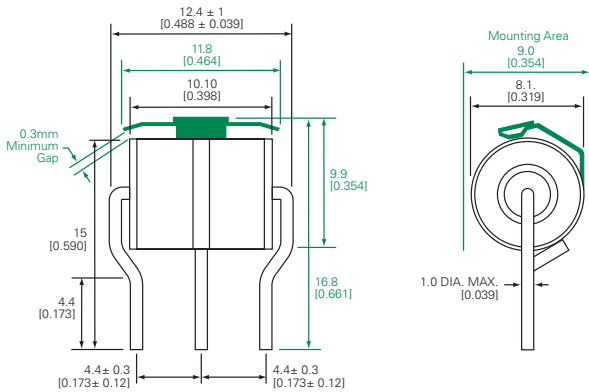

#### Type 06 - Straight Radial Leads

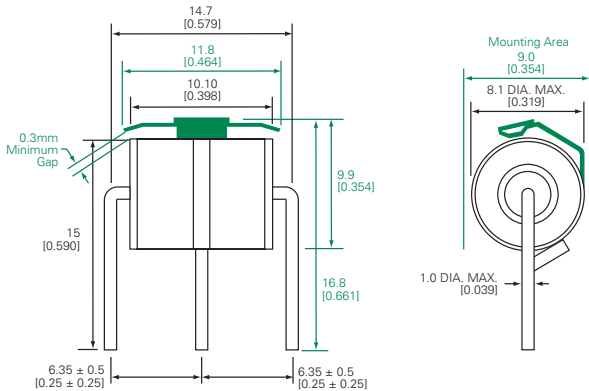

#### Type 14 - Straight "T" Leads

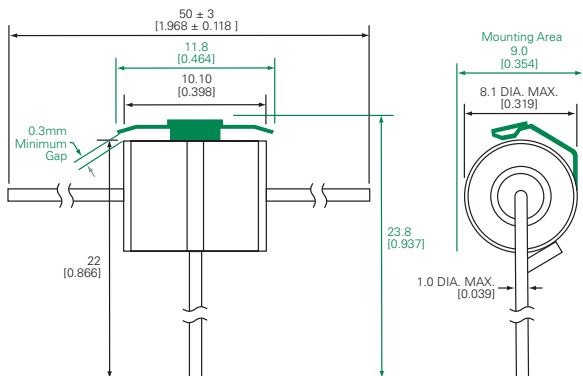

### Packaging

Device Type	Description	Quantity
Type 01	100pcs/tray x 5 trays per carton	500
Type 04	100pcs/tray x 5 trays per carton	500
Type 06	100pcs/tray x 5 trays per carton	500
Type 14	50pcs/tray x 5 trays per carton	250

### Part Numbering System

#### PMT3(310) XXX XX X

