

THIS DRAWING IS UNPUBLISHED. RELEASED FOR PUBLICATION NOV, 2006.
 © COPYRIGHT 2006 BY TYCO ELECTRONICS CORPORATION. ALL RIGHTS RESERVED.

LOC	DIST	REVISIONS					
E	B	P	LTR	DESCRIPTION	DATE	DWN	APVD
		A		FIRST ISSUE	16NOV06	JMS	FWK

- NOTES**
- 1 SINGLE PACK IN ACCORDANCE WITH AMP SPEC 107-3275
 - 2 100 TRAY PACK IN ACCORDANCE WITH AMP SPEC 107-3275
 - 3 Ni PLATING
 4. HAND TOOL: 9-1478240-0
 5. ELECTRICAL CHARACTERISTICS
 FREQUENCY RANGE: DC - 2 GHz
 NOMINAL IMPEDANCE: 75 Ohm
 INSULATION RESISTANCE: N/A
 WORKING VOLTAGE: N/A
 DIELECTRIC WITHSTAND VOLTAGE: N/A
 CONTACT RESISTANCE: N/A
 CENTRE CONTACT: N/A
 OUTER CONTACT: N/A
 VSWR @ 3GHz: 1.35:1
 INSERTION LOSS dB @ x 1.5 GHz: N/A
 6. MECHANICAL CHARACTERISTICS
 COUPLING NUT PROOF TORQUE: 3.4 Nm
 CABLE RETENTION FORCE: N/A
 DURABILITY: 50 Cycles Min
 7. ENVIRONMENTAL CHARACTERISTICS
 OPERATING TEMPERATURE: -55 to +85 DegC
 8. FOR TECHNICAL DATA REFER TO YOUR LOCAL TYCO ELECTRONICS SALES OFFICE
 9. ALL DIMENSIONS ARE NOMINAL FOR REFERENCE ONLY UNLESS OTHERWISE STATED

-	9.50	19.40	6.00	6.70	8.70	10.00	10.50	CT125	5-1814821-7
-	9.50	19.40	6.00	6.70	8.70	10.00	10.50	CT125	5-1814821-6
9-1478243-0	8.50	19.40	4.85	5.70	7.70	9.00	9.50	CT100	5-1814821-5
9-1478243-0	8.50	19.40	4.85	5.70	7.70	9.00	9.50	CT100	5-1814821-4
1583581-1	10.20	19.40	4.85	5.50	9.50	10.80	11.20	RG6/U	5-1814821-3
1583581-1	10.20	19.40	4.85	5.50	9.50	10.80	11.20	RG6/U	5-1814821-2
9-1478243-0	8.50	20.40	3.90	4.70	7.50	9.00	9.50	RG59B/U, 62A/U, 140/U, 210/U, URM90, Belden 9291, 9291, KX6A, KX25, KX52, KX53	5-1814821-1
9-1478243-0	8.50	20.40	3.90	4.70	7.50	9.00	9.50	RG59B/U, 62A/U, 140/U, 210/U, URM90, Belden 9291, 9291, KX6A, KX25, KX52, KX53	5-1814821-0
DIE SET	G	F	E	D	C	B	A	CABLE GROUPS	PART NO.

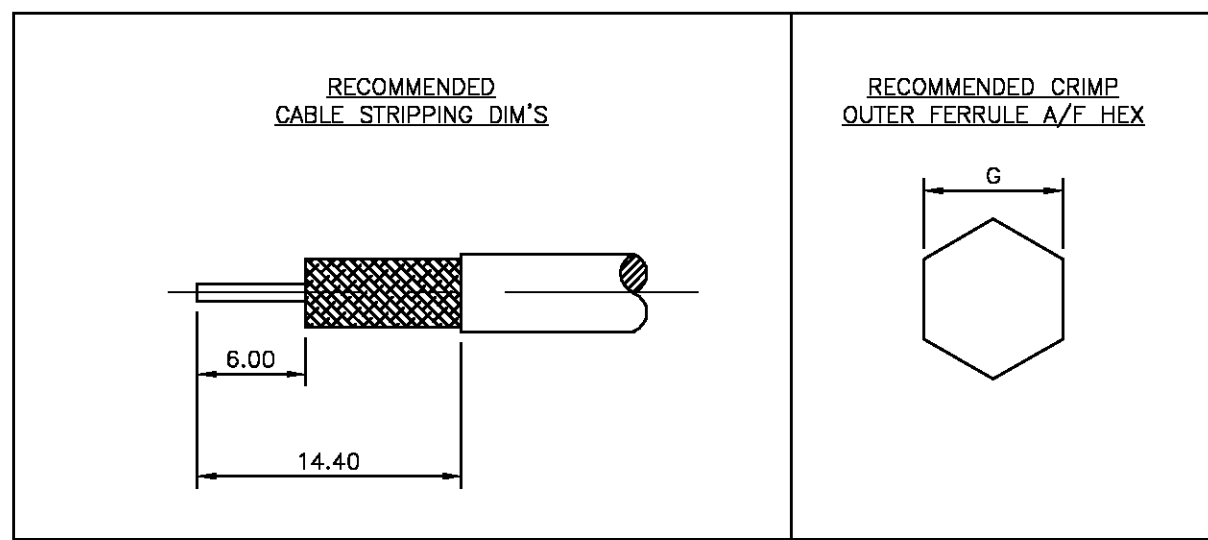
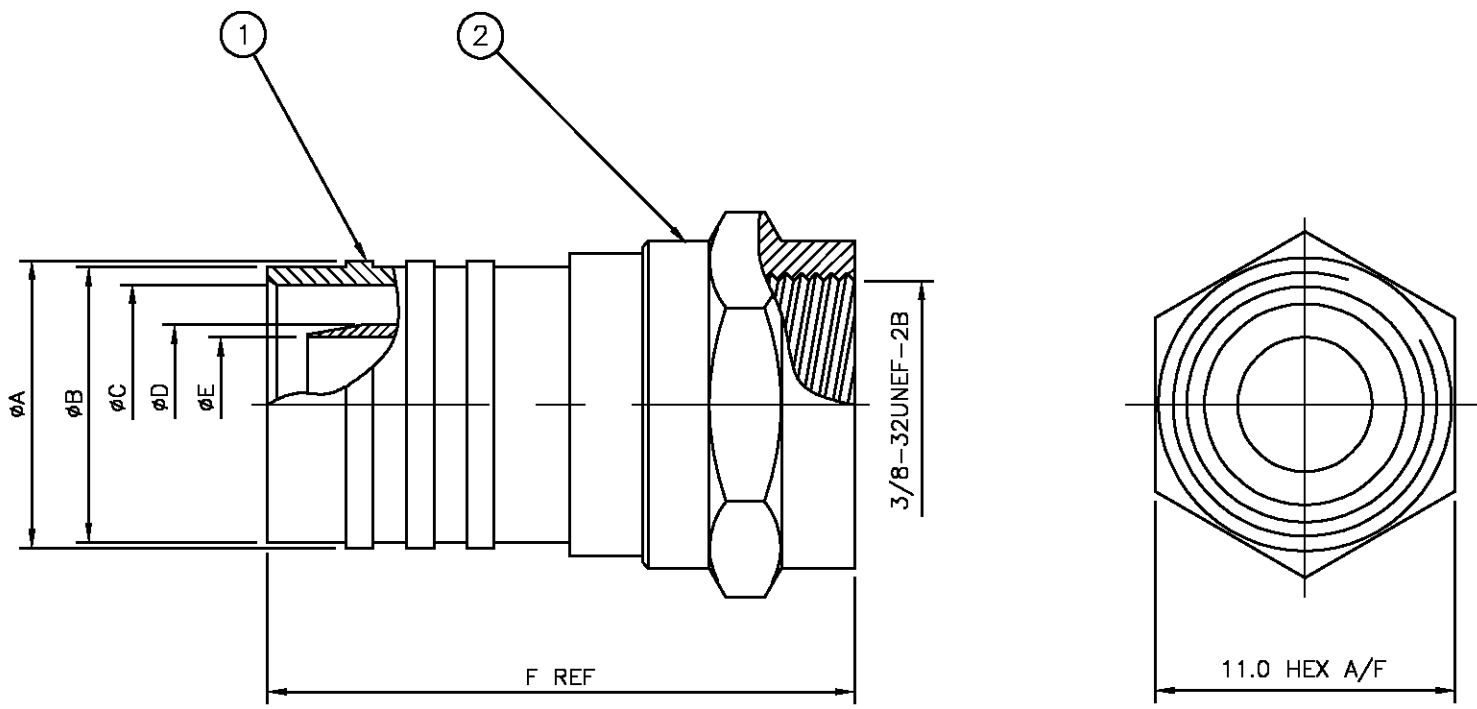

1	1	1	1	1	1	1	1	1	ZINC ALLOY	△	COUPLING NUT	2
1	1	1	1	1	1	1	1	1	BRASS	△	BODY	1
5	75	65	55	45	35	25	15	0	MATERIAL		DESCRIPTION	ITEM

THIS DRAWING IS A CONTROLLED DOCUMENT.

DWN J.SANDWELL 16NOV06
 CHK S.PARLOW 16NOV06
 APVD F.WHEELER-KING 16NOV06

tyco Electronics Tyco Electronics Corporation
 Bideford, UK, EX39 4HE

NAME: F TYPE STR PLG HEX

PRODUCT SPEC: -
 APPLICATION SPEC: -
 WEIGHT: -

SIZE: A3 CAGE CODE: 00779 DRAWING NO: C-1814821 RESTRICTED TO: -

CUSTOMER DRAWING SCALE: NTS SHEET: 1 OF 1 REV: A